



Investor Presentation

October 3, 2024

Nasdaq: NDSN

Ascend

STRATEGY



NBS NEXT



OWNER MINDSET



WINNING TEAMS

Safe Harbor Statement

Under the Private Securities Litigation Reform Act of 1995

Certain statements contained in this release are forward-looking statements within the meaning of the Private Securities Litigation Reform Act of 1995. Forward-looking statements may be identified by terminology such as “such as “anticipates,” “supports,” “plans,” “projects,” “expects,” “believes,” “should,” “would,” “could,” “hope,” “forecast,” “management is of the opinion,” use of the future tense and similar words or phrases.. These statements reflect management’s current expectations and involve a number of risks and uncertainties. These risks and uncertainties include, but are not limited to, U.S. and international economic conditions; financial and market conditions; currency exchange rates and devaluations; possible acquisitions, including the Company’s ability to successfully integrate acquisitions; the Company’s ability to successfully divest or dispose of businesses that are deemed not to fit with its strategic plan; the effects of changes in U.S. trade policy and trade agreements; the effects of changes in tax law; and the possible effects of events beyond our control, such as political unrest, including the conflicts in Europe and the Middle East, acts of terror, natural disasters, pandemics and the other factors discussed in Item 1A (Risk Factors) in the Company’s most recently filed Annual Report on Form 10-K and in its Forms 10-Q filed with the Securities and Exchange Commission, which should be reviewed carefully. The Company undertakes no obligation to update or revise any forward-looking statement in this press release.



Nordson is a growth compounder with unique competitive advantages

Company Founded

2024 TTM Revenue

2024 TTM EBITDA%

Employees

Countries with Direct Presence

1954

\$2.6B

31%

8,600

35+

** 2024 is NDSN Q3 TTM as reported*



By the Numbers

Consistent Record
of Growth

Demonstrated
Value to
Customers

Disciplined focus
on profitability

Solid Returns

Differentiated
Product Portfolio*

Consistent value to
shareholders

3%

Sales Growth

55%

Gross Margins

29%

EBITDA Margins

15%

ROIC

2,500+

Global Patents
Held

61 yrs.

of Annual
Dividend
Increases

Commitment to ESG



Diversified Board of Directors

- 50% diverse board (3 gender and 2 racially or ethnically diverse)
- 9 out of 10 independent directors
- 6 years average tenure



Strong Culture and Values

- Nordson Impact – Invest 5% of domestic pretax earnings in communities
- Paid time off for volunteer hours
- Employee support programs



Environmental Stewardship

- Product design improvements focused on reducing customers' material utilization
- Journey to Zero adverse impacts to employees and community

Diversified Sources of Sales

FY2023 Profile - \$2.6 Billion

Product Type

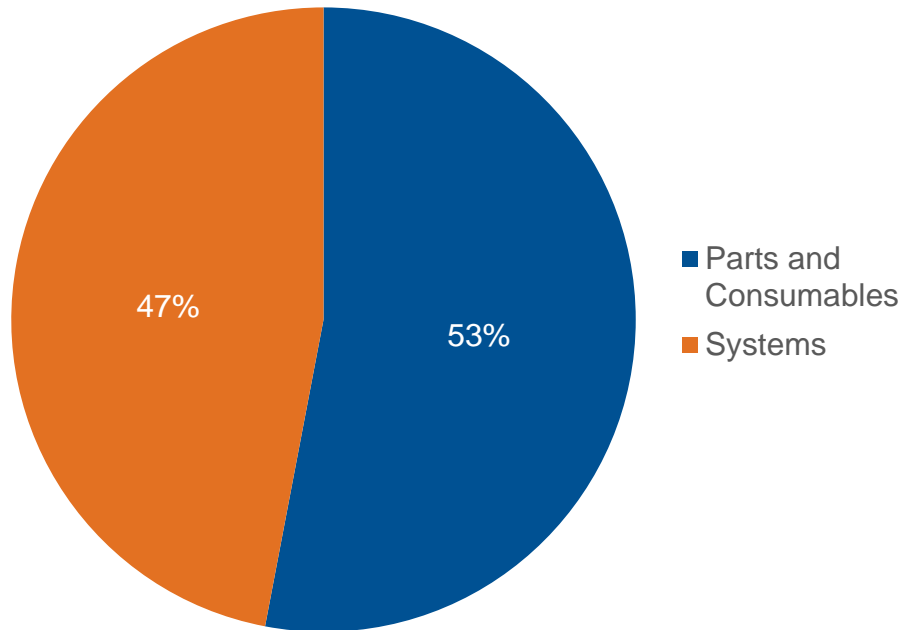

High percentage of recurring sales from parts and consumables.

Geographies

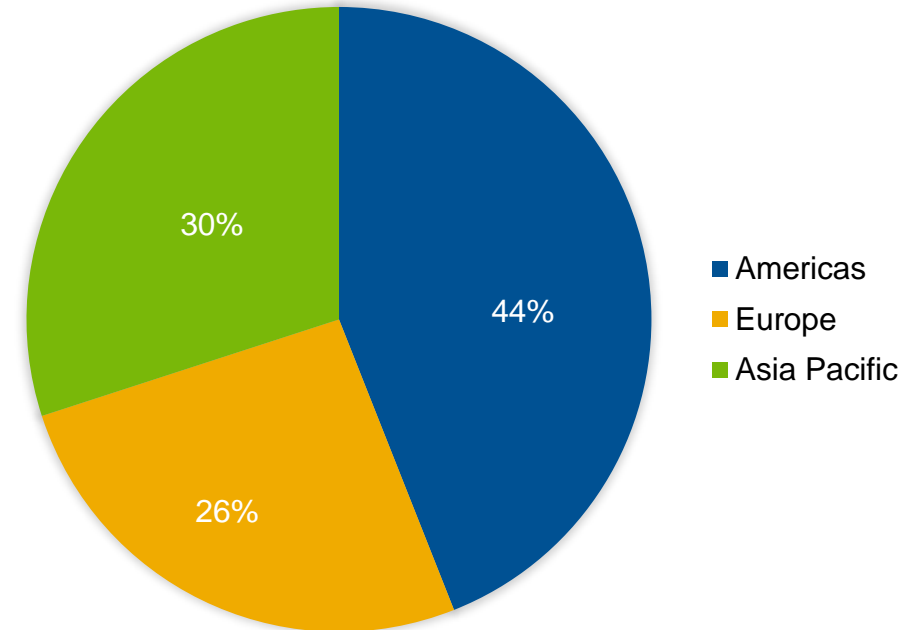

Diversified geographic footprint. Direct presence in over 35 countries.

Diversified End Markets

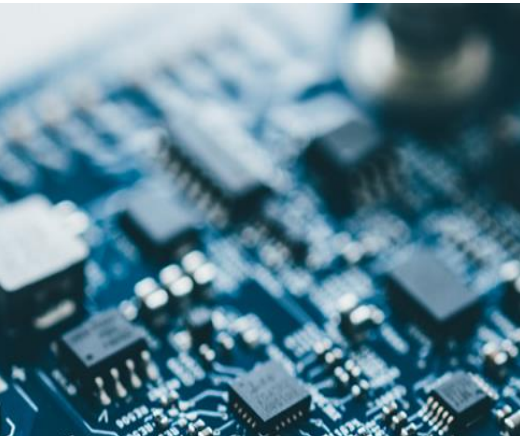

Electronics
27% of revenue

- Semiconductor packaging
- Wafer-level packaging
- Printed circuit boards
- Electronic component assembly – mobile phone, camera, ear buds, PC
- Automotive electronics



Consumer Non-Durables
23% of revenue

- Box sealing
- Baby diapers
- Convenience food packaging
- Beverage straw and spot attachment
- Container and bottle labeling



Medical
22% of revenue

- Balloons, extrusions, delivery catheters and other minimally invasive devices
- Single-use fittings, connectors, fluid transfer components in medical equipment and surgical procedures
- Single-use specialty cannula for cardio-pulmonary procedures



Industrial
15% of revenue

- Construction and industrial machinery
- Rigid container
- Aerospace
- Chemical
- Defense
- Energy

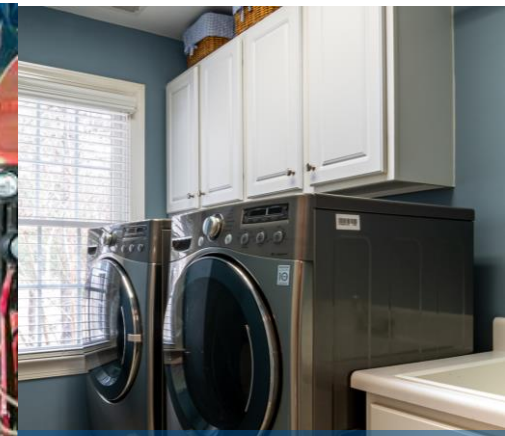

Remaining Markets
13% of revenue

- Consumer durable
- Automotive
- Animal health & delivery systems

How We Are Organized

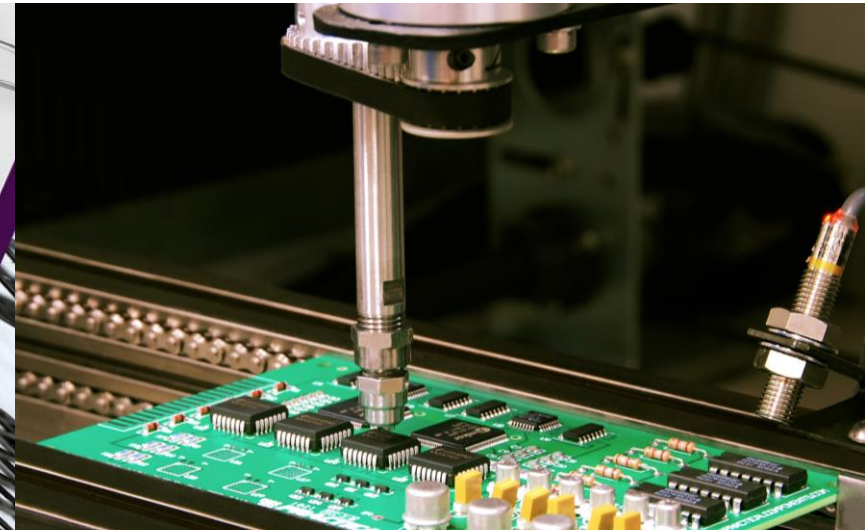

INDUSTRIAL PRECISION SOLUTIONS

Adhesives, Industrial Coatings,
Measurement and Control Solutions & Polymer Processing Systems

53%
REVENUE

MEDICAL FLUID SOLUTIONS

Interventional Solutions, Fluid Components
& Engineered Fluid Dispensing

25%
REVENUE

ADVANCED TECHNOLOGY SOLUTIONS

Electronic Processing Systems
& Test and Inspection

22%
REVENUE

Industrial Precision Solutions

What We Do

Product lines reduce material consumption, increase line efficiency, and enhance product brand and appearance. Components are used for dispensing adhesives, coatings, paint, finishes, sealants and other materials. This business primarily serves the industrial, consumer durables and non-durables markets.

2023 Revenues

\$1,391M

2023
Operating
Margin*

34%

2023
EBITDA

36%

Long-Term Growth Driven By:

- Material, machinery and process innovations
- Emerging markets and product tiering
- New applications, including electric vehicle battery, automotive electronics, and fabric bonding
- Recapitalization of large installed base
- Deploying NBS Next in our divisions

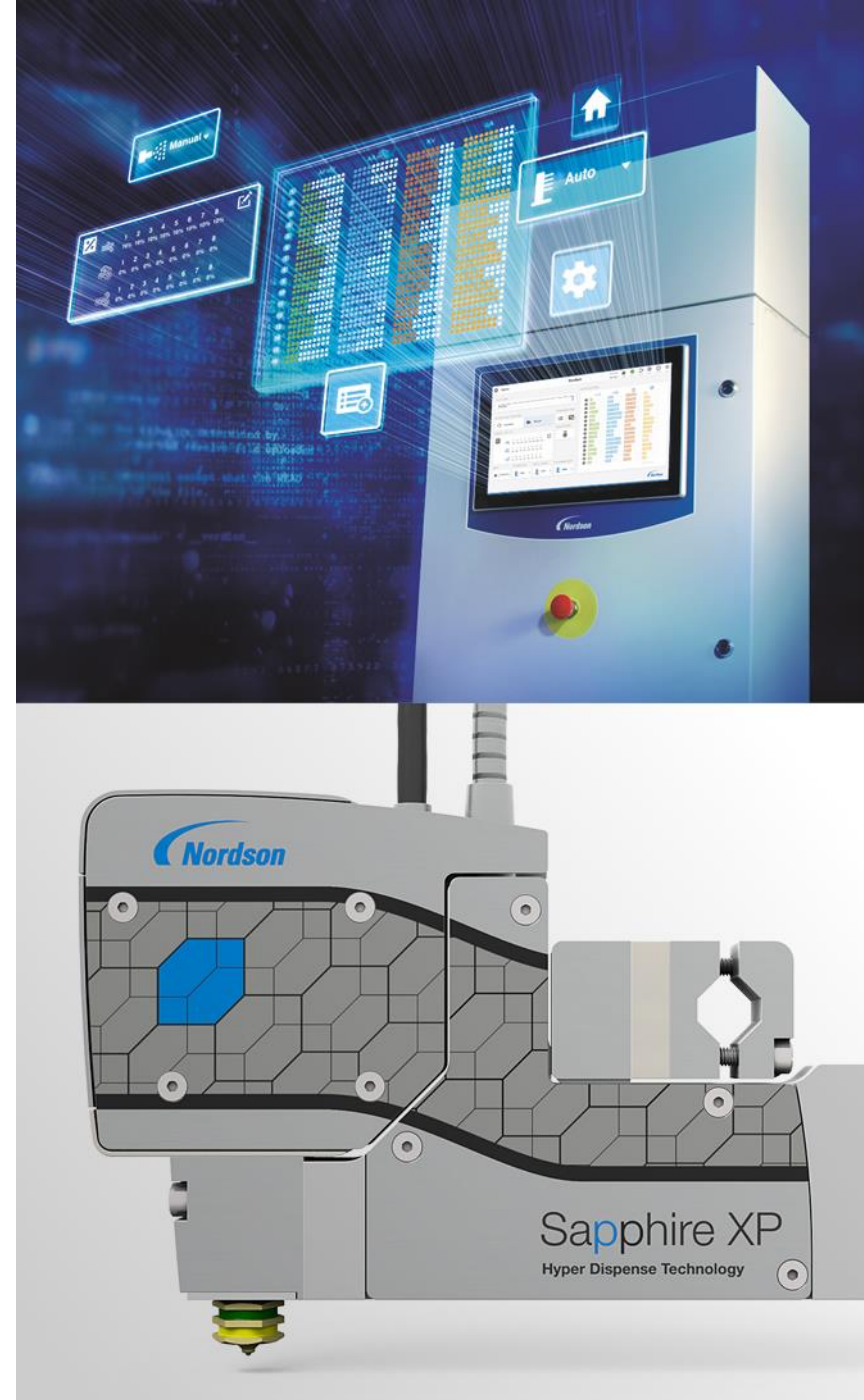

Medical Fluid Solutions

What We Do

Fluid management solutions for medical, high-tech industrial and other diverse end markets. Related plastic tubing, balloons, catheters, syringes, cartridges, tips, and fluid connection components are used to dispense or control fluids within customers' medical devices or products, as well as production processes.

Long-Term Growth Driven By:

- Aging population
- Trends toward non-invasive surgical techniques
- Medical OEM outsourcing
- Emerging markets
- Deploying NBS Next in our divisions

2023 Revenues

\$660M

2023
Operating
Margin*

29%

2023
EBITDA

37%

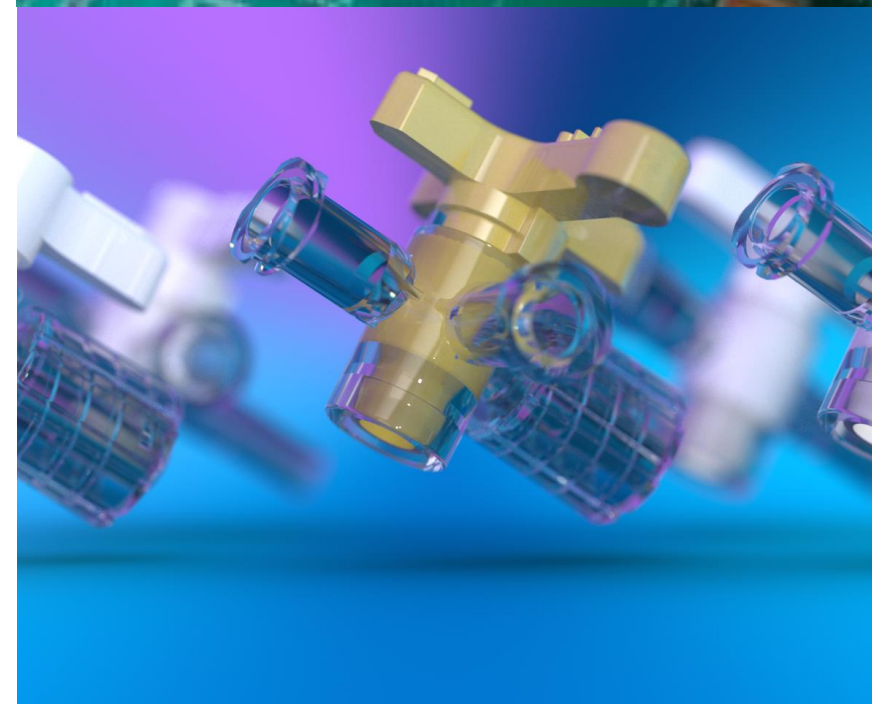

Advanced Technology Solutions

What We Do

Design and develop proprietary technologies found in progressive stages of an electronics customer's production processes, such as surface treatment, precisely controlled dispensing of material and test and inspection to ensure quality and reliability.

Long-Term Growth Driven By:

- Electronics - Broad solutions across the electronics supply chain
- 5G / AI / Big Data / Auto Electronics / Autonomous Vehicles / High-Perf Computing
- Emerging markets
- Deploying NBS Next in our divisions

2023 Revenues

\$577M

2023
Operating
Margin*

20%

2023
EBITDA

23%





Why Invest in Nordson?

Ascend

STRATEGY

A Diversified Precision
Technology Company

REVENUE

\$3B+

EBITDA

30%

Long-term 2025 financial targets

Top tier growth with leading margins and returns



NBS
Next

GROWTH FRAMEWORK

- Sustained organic growth
- Accelerate acquisitions



Owner
Mindset

DIVISION-LED

- Data drives action
- Entrepreneurial, accountable



Winning
Teams

TALENT STRATEGY

- Enhance depth and diversity
- Enrich inclusive culture

Culture & Values

Ascend Strategy Delivers

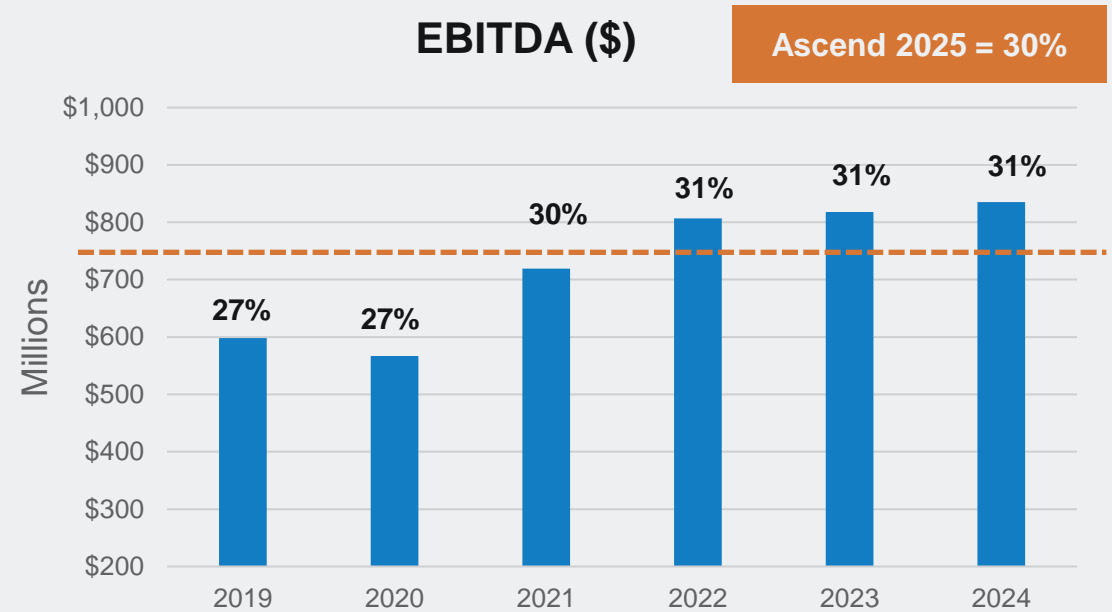
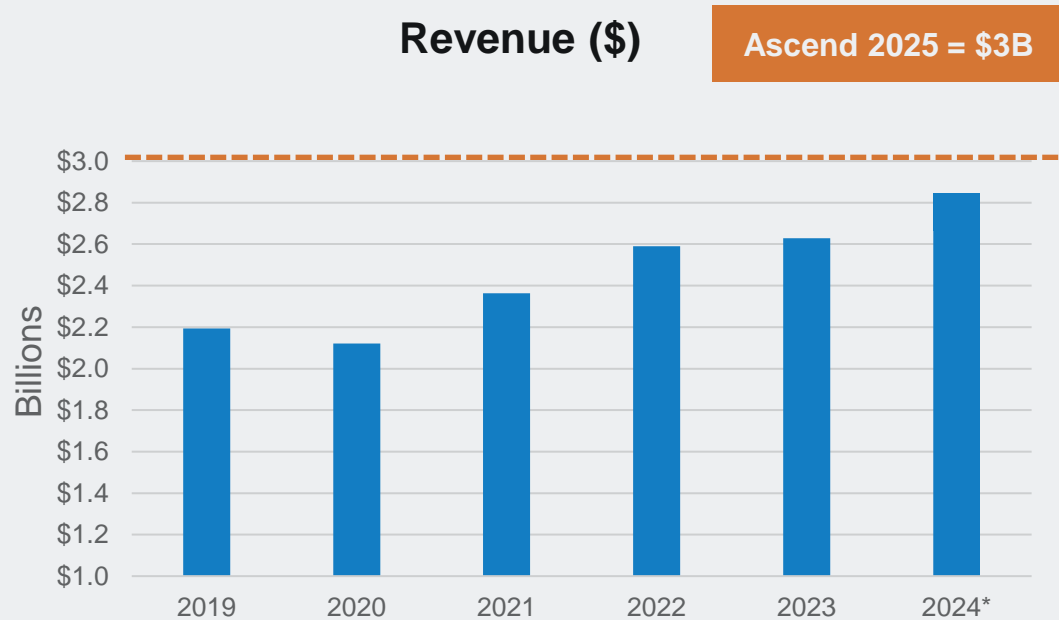

Tracking toward 2025 financial targets

A Growth Portfolio Ready to Accelerate

2014 (FY Revenue \$1.7B)

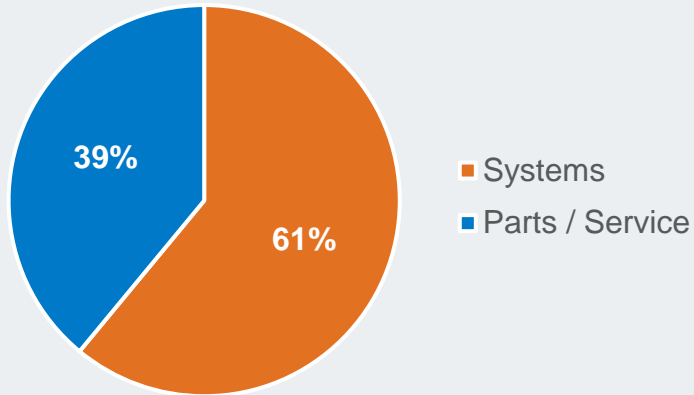

2024 (TTM Revenue \$2.7B)

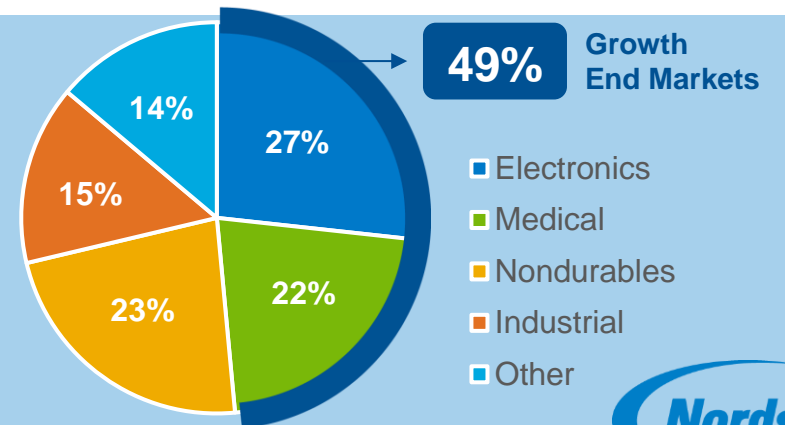
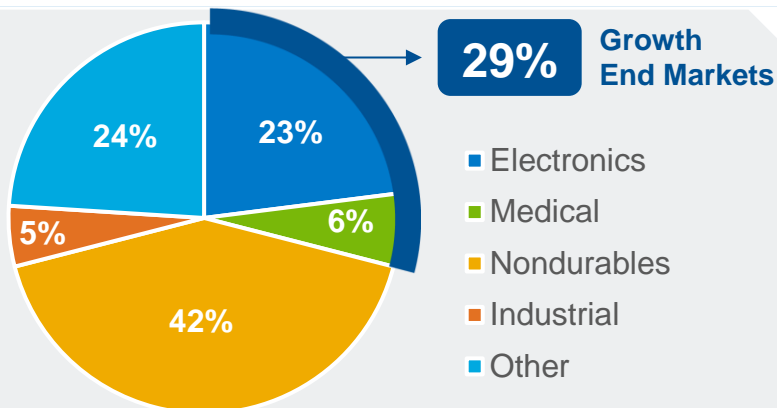
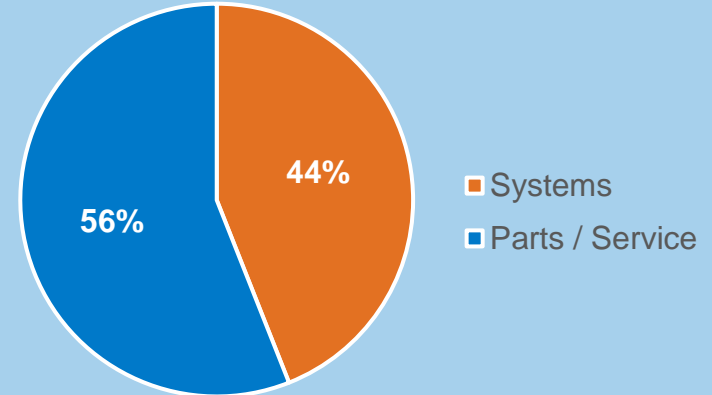

2025-2029 Financial Targets

Ascend

STRATEGY

Revenue
Growth

6-8%

Adjusted EPS
Growth

10-12%

Average annual growth

Growth Compounder



NBS
Next

GROWTH FRAMEWORK



Owner
Mindset

DIVISION-LED



Winning
Teams

TALENT STRATEGY

Engaged Employees Driven by Nordson Values



NBS Next

GROWTH FRAMEWORK

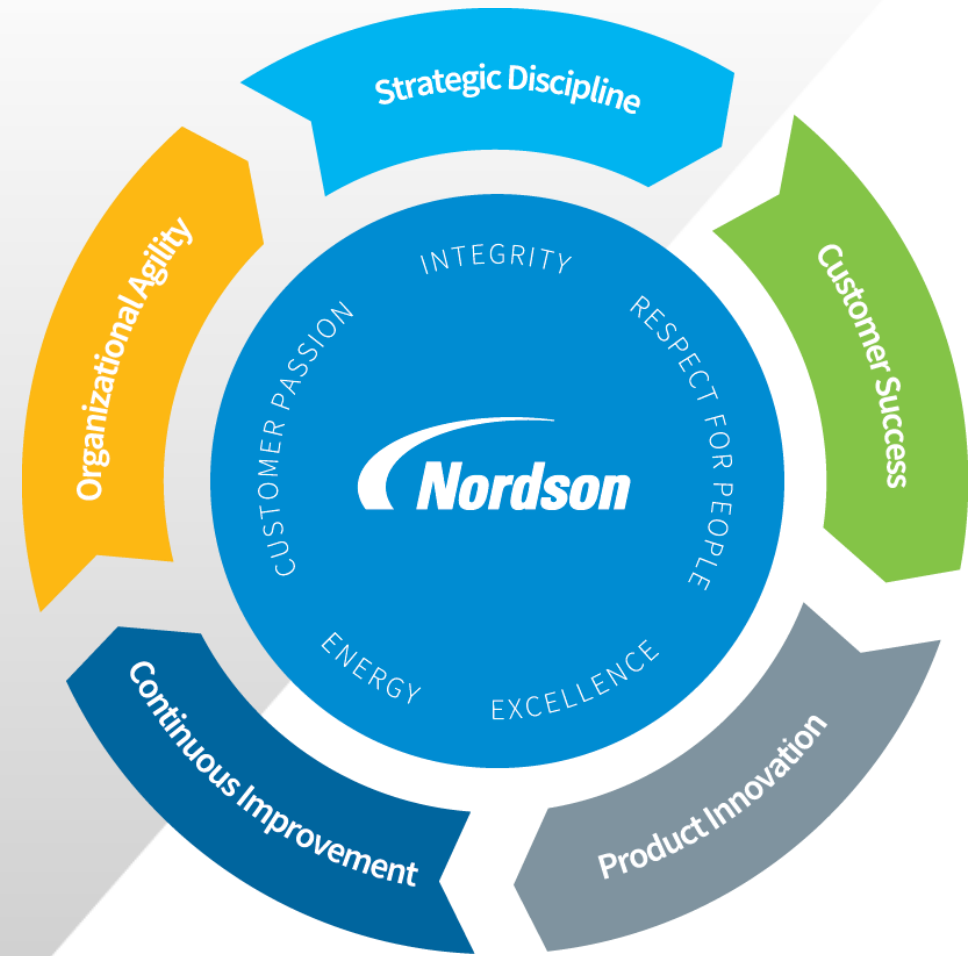

Driving profitable growth by selecting and investing disproportionately in the best growth opportunities





Owner Mindset

DIVISION-LED

Entrepreneurial division-led organization:

- **Decisions close to the customer**
- **Autonomy + Accountability**
- **Clear line of sight to deploying NBS Next**



Winning Teams

TALENT STRATEGY

A key ingredient to successful execution of the Ascend strategy:

- **Leaders inspiring trust and building followership in the organization**
- **Focus on inclusion and diversity in everything we do**
- **Create an engaging culture that attracts and retains top talent**

Disciplined Approach to M&A



Strategic Criteria

- Serving attractive end market niches and applications
- Differentiated product technologies/solutions
- Additive to our growth focused portfolio



Financial Criteria

- Growth at or above market rates with Nordson-like gross margins
- EBITDA ~20+% with margin expansion opportunities
- Returns that sufficiently exceed our cost of capital

M&A Strategy

Programmatic capital deployment creating significant value

Estimated Contribution of Acquisitions to Enterprise Value

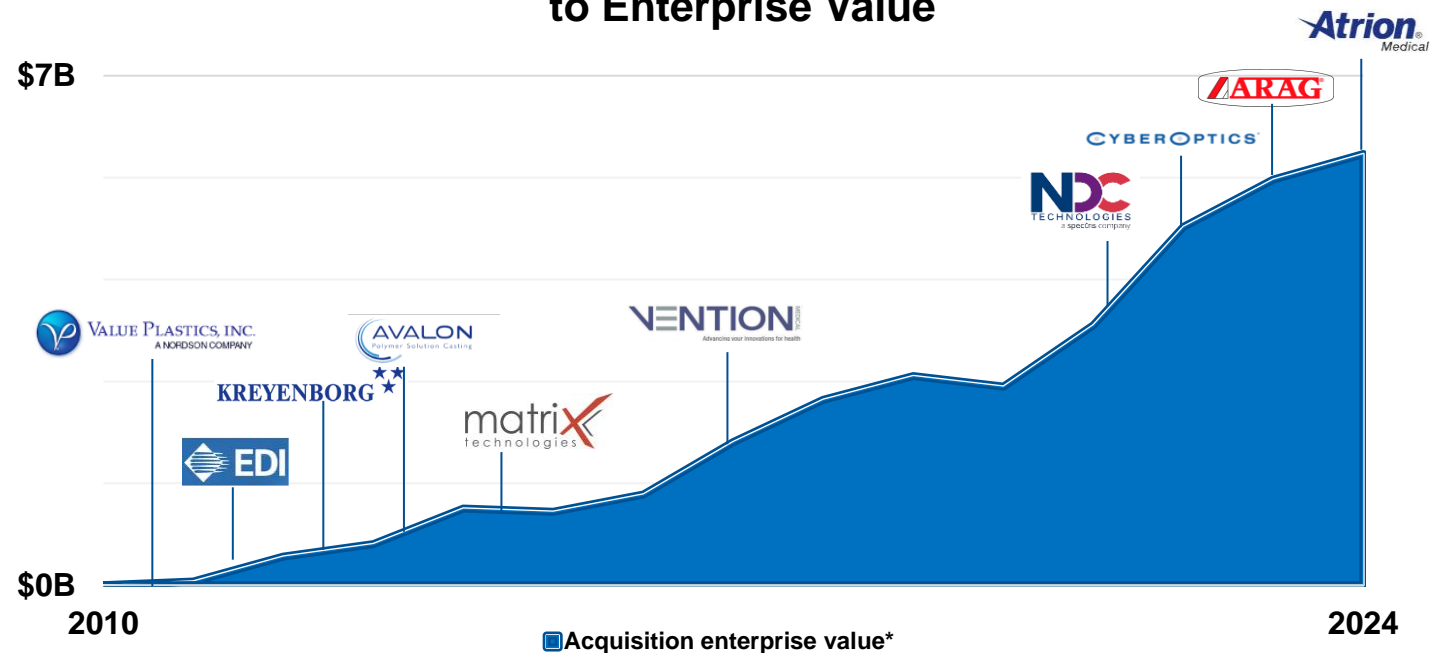

*EV calculated as incremental EBITDA at current Nordson multiple of 18x

Selected Portfolio Enhancements

- Expanded test and measurement technologies
- Entered precision agriculture platform
- Created scaled medical platform

Growth Algorithm

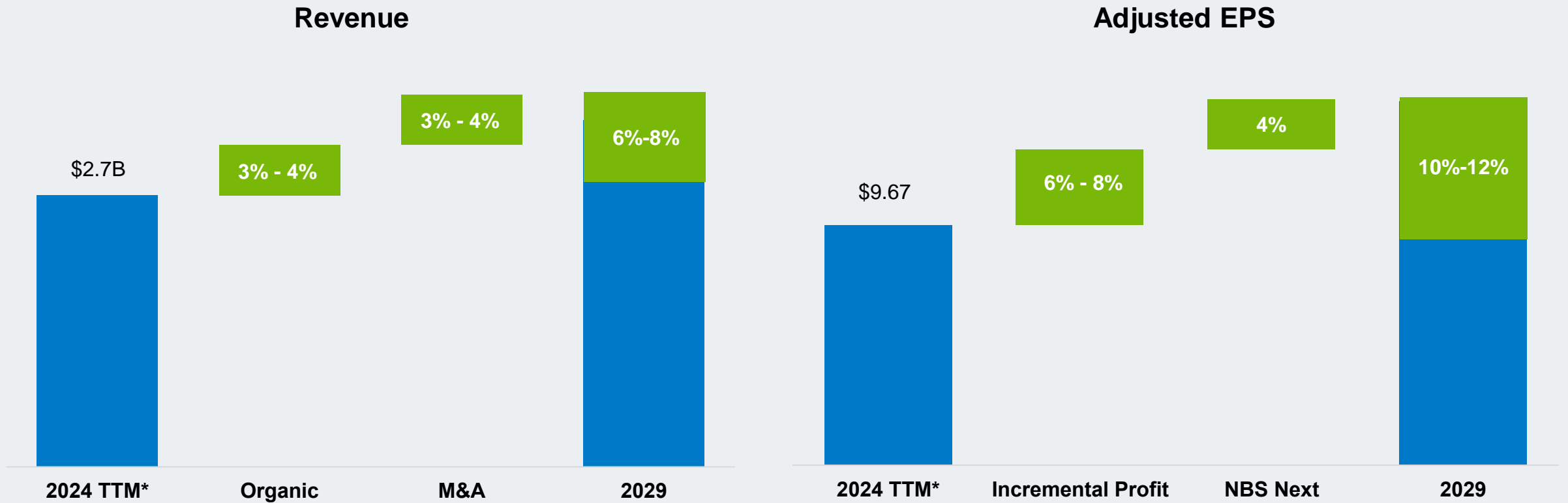

*Figures based on TTM Q3 fiscal 2024

Superior Conversion / Deployment of Cash Flows

Generation of ~ \$4.1B in operating cash flows through 2029

Capital Deployment through 2029

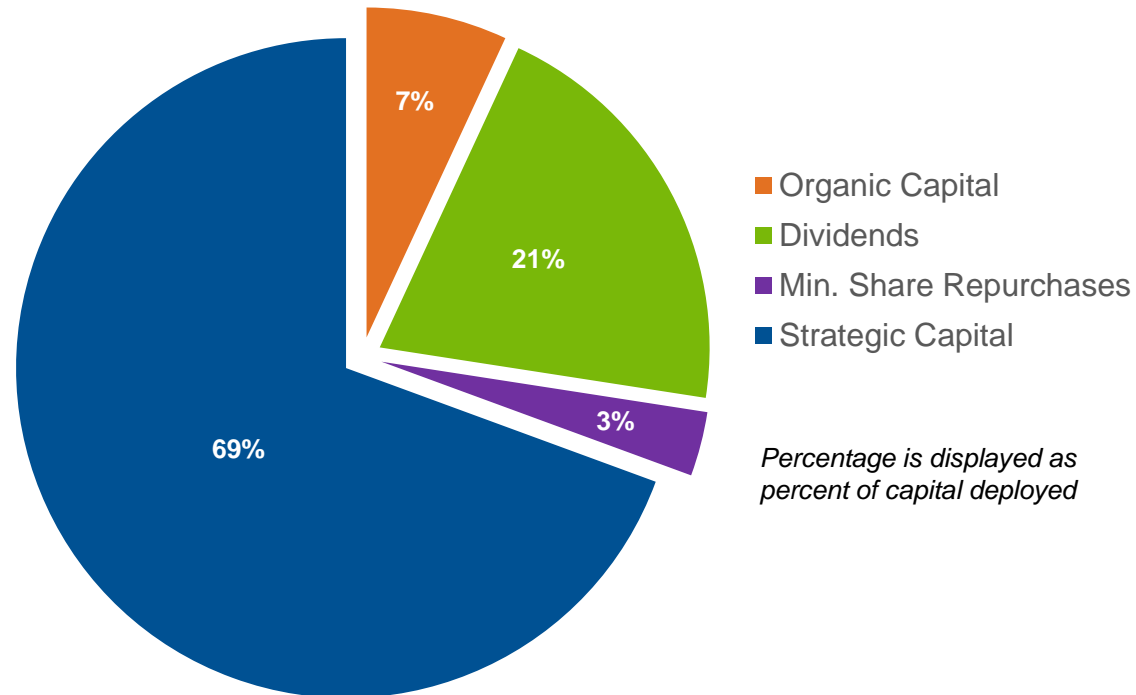

Cash Flow Deployment Priorities

- Fund organic growth
- Return to shareholders thru dividends and routine stock repurchases to offset dilution
- Strategic deployment of ~\$2.8B for:
 - Strategic M&A
 - Debt service
 - Additional share repurchases



Recent Financial Results

Total Company – 3Q 2024



Sales

- Reported sales increased 2%, inclusive of 1% organic decline; 4% acquisitive growth
- Strong growth in industrial product lines, offset by softness in electronics, primarily semiconductor, and medical product lines
- Organic sales increase in Asia Pacific offset by softness in Americas and Europe

EBITDA*

- EBITDA was \$208 million, or 31% of sales
- Operating profit margin 26% of sales
- Strong gross margin of 56% was offset by higher SG&A costs largely attributable to the addition of ARAG

3Q 2024 Sales Bridge**

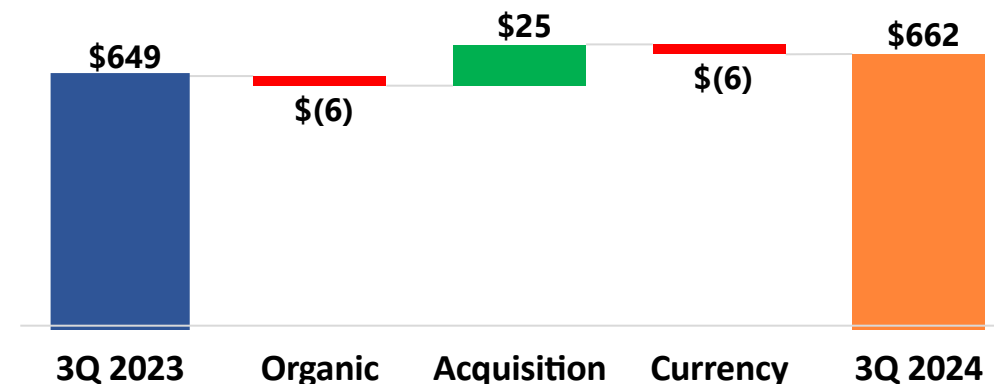

	3Q 2023	3Q 2024	Δ
Sales	\$648.7	\$661.6	2%
Operating Profit*	\$180.8	\$174.8	-3%
EBITDA*	\$207.9	\$208.1	Flat
EPS GAAP	\$2.22	\$2.04	-8%
EPS Adjusted*	\$2.55	\$2.41	-6%

Strong Cash Flow with Sufficient Liquidity to Invest in Strategic Initiatives

Net Debt

- Cash on hand totaled \$165 million
- Net debt of \$1.3 billion
- Leverage ratio of 1.6x at the end of 3Q 2024

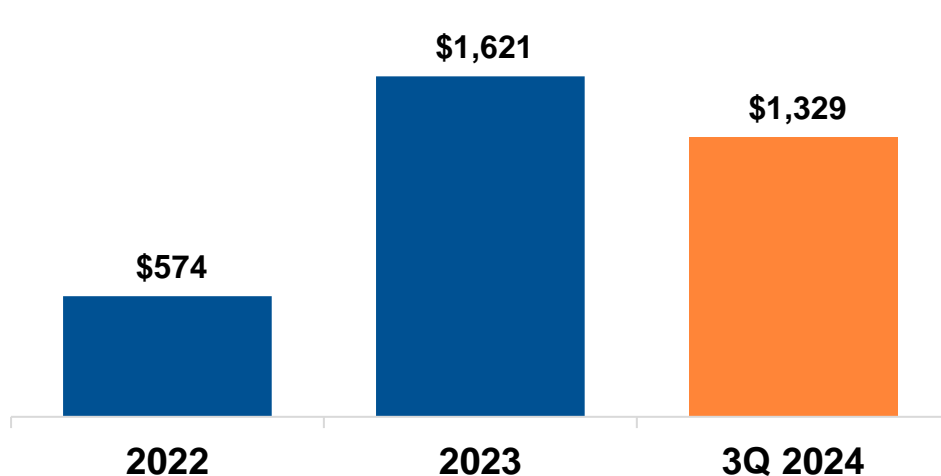

Free Cash Flow

- Strong free cash flow of \$143 million
- Year-to-date free cash flow of \$416 million; cash conversion rate on net income is 121%
- Marked 61 consecutive years of dividend increases

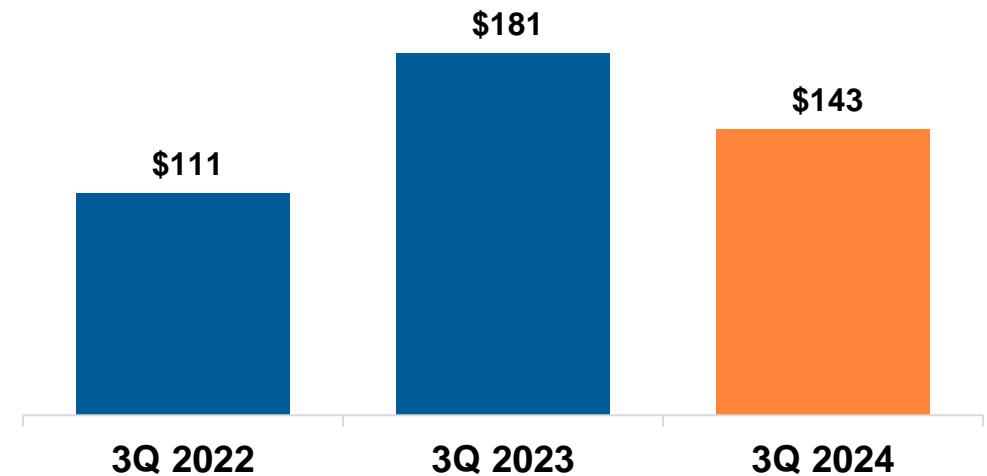

Full-Year Fiscal 2024 Guidance



Full-year guidance as of 8/21/2024

- Mid-point of sales increases \$30 million, reflecting addition of Atrion
- Full-year adjusted EPS guidance unchanged, inclusive of Atrion acquisition, which is expected to be slightly dilutive in the fourth quarter

Full-Year Sales Guidance

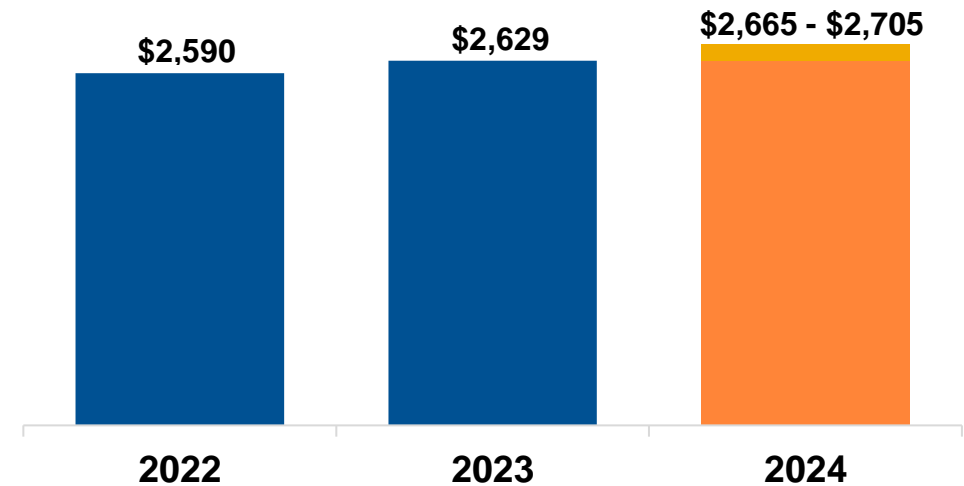

Full-Year Adjusted EPS Guidance*

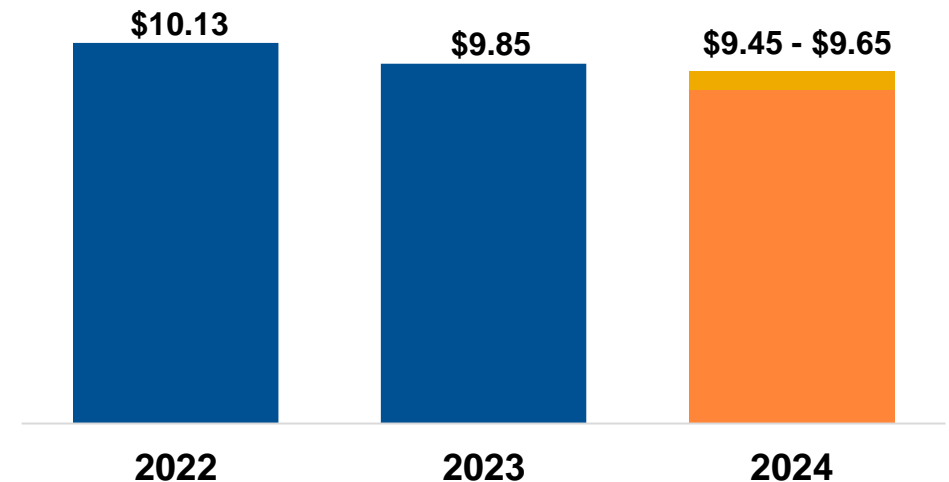

Appendix 1:

Product Innovation

Our Electronics Industry Position

Surface Mount Manufacturing

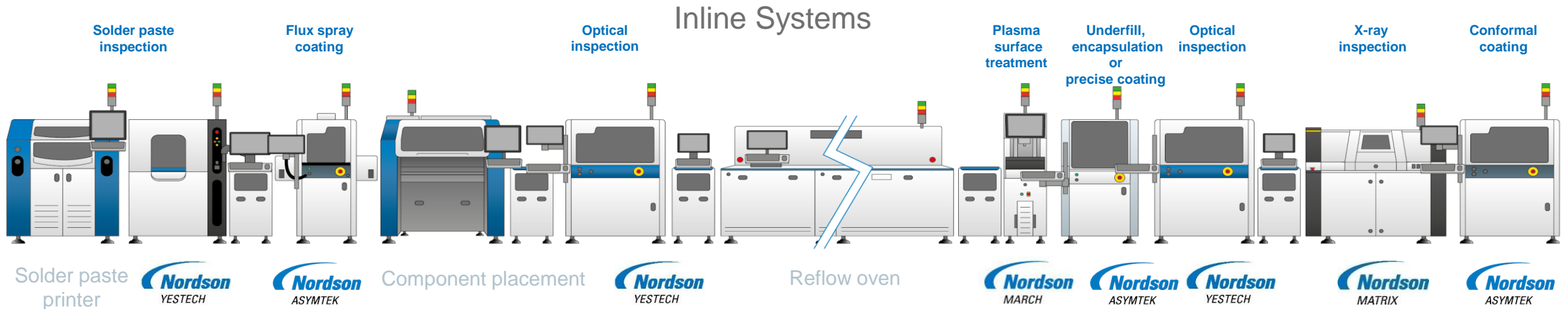

QA Lab / Island of Automation

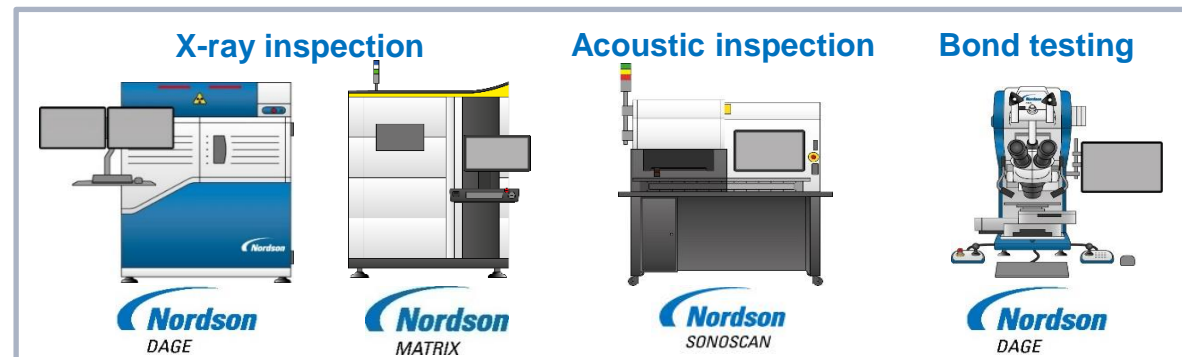

Our Role in the Semiconductor Process

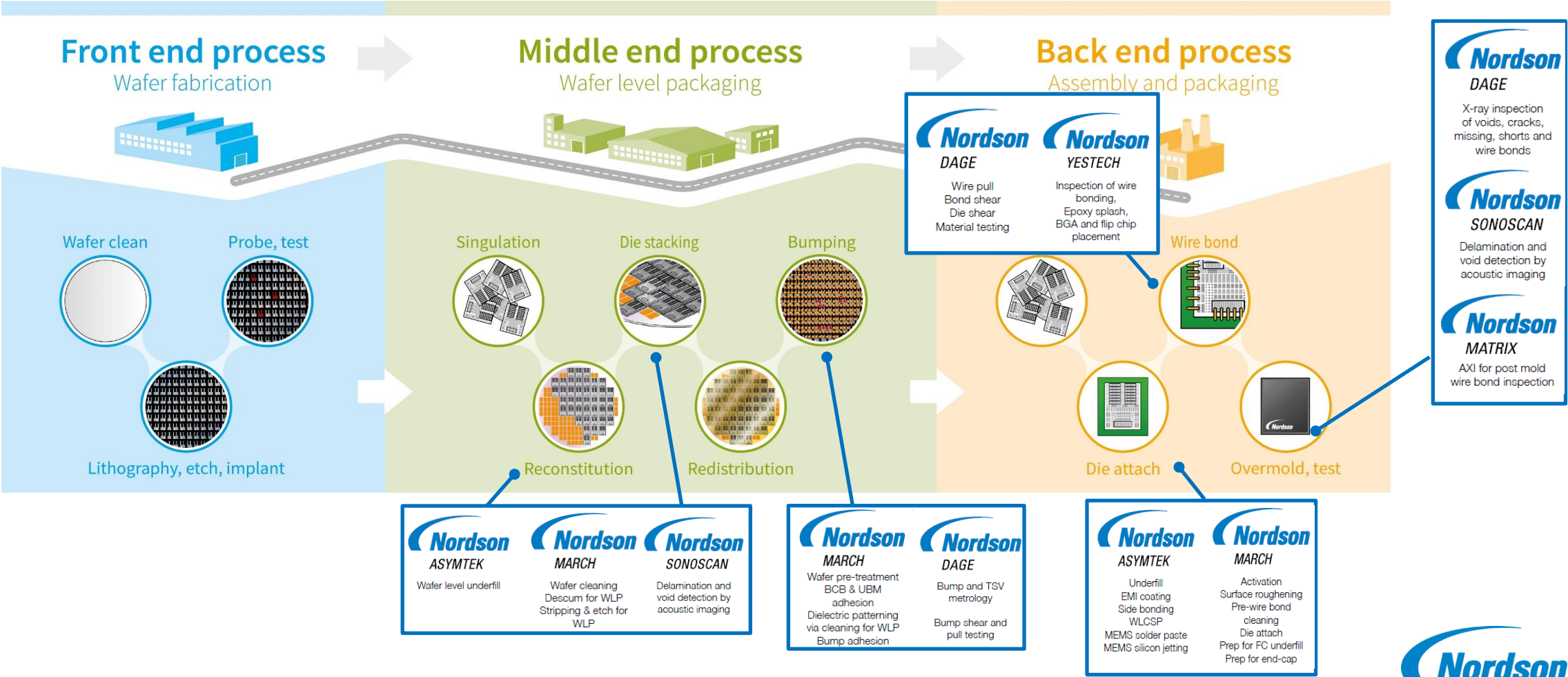

CyberOptics expands market opportunities

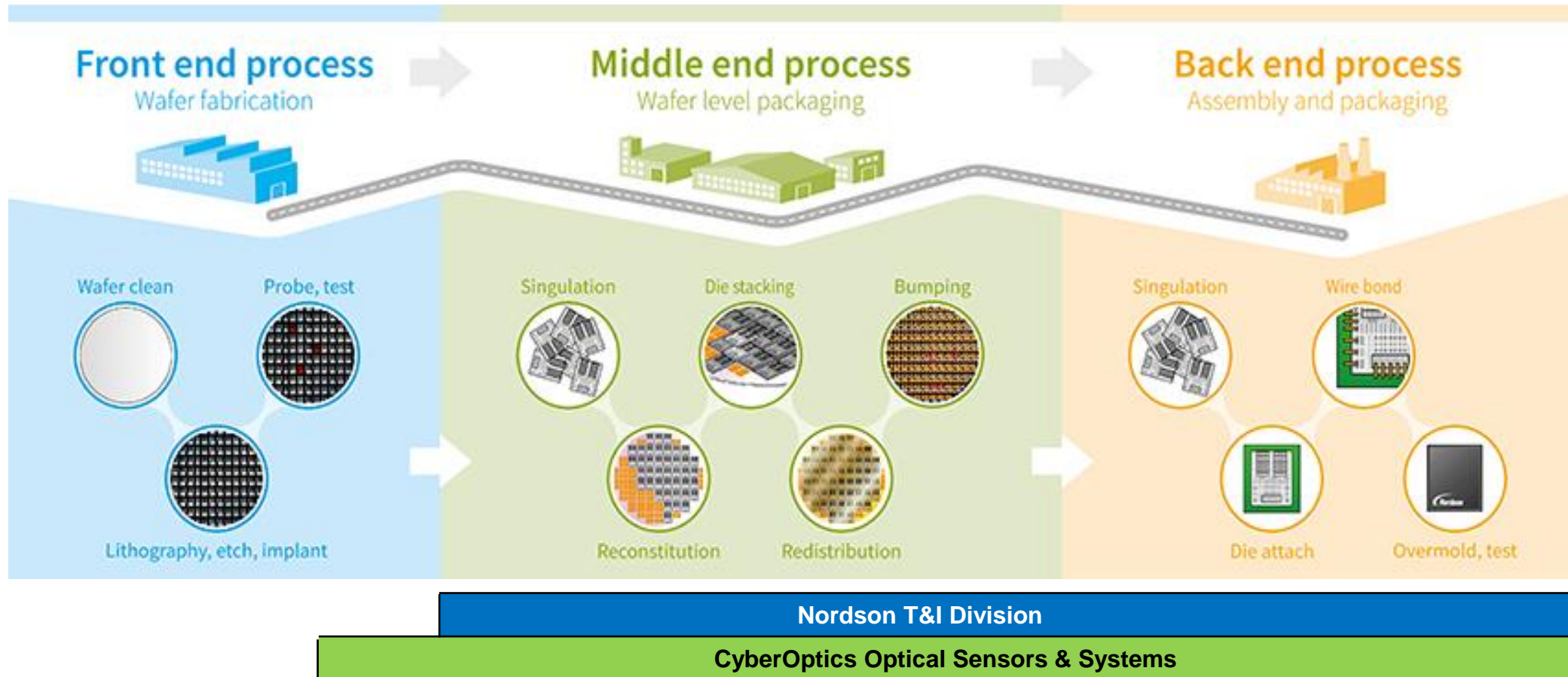

*3D Optical semi market expected to grow ~15%+,
exceeding the broader 'Wafer Fab Equipment' market LSD '23 – '25 growth*

Advances in Semiconductor Packaging



2D Architecture

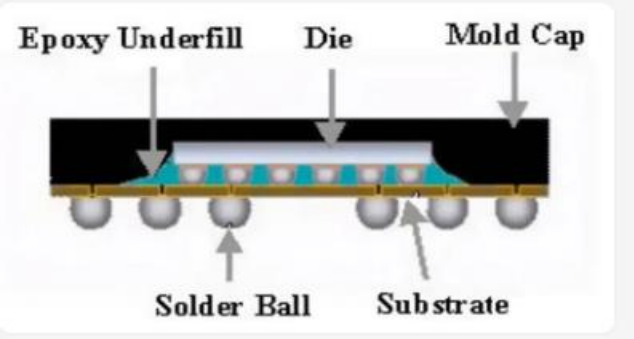

2.5D Architecture

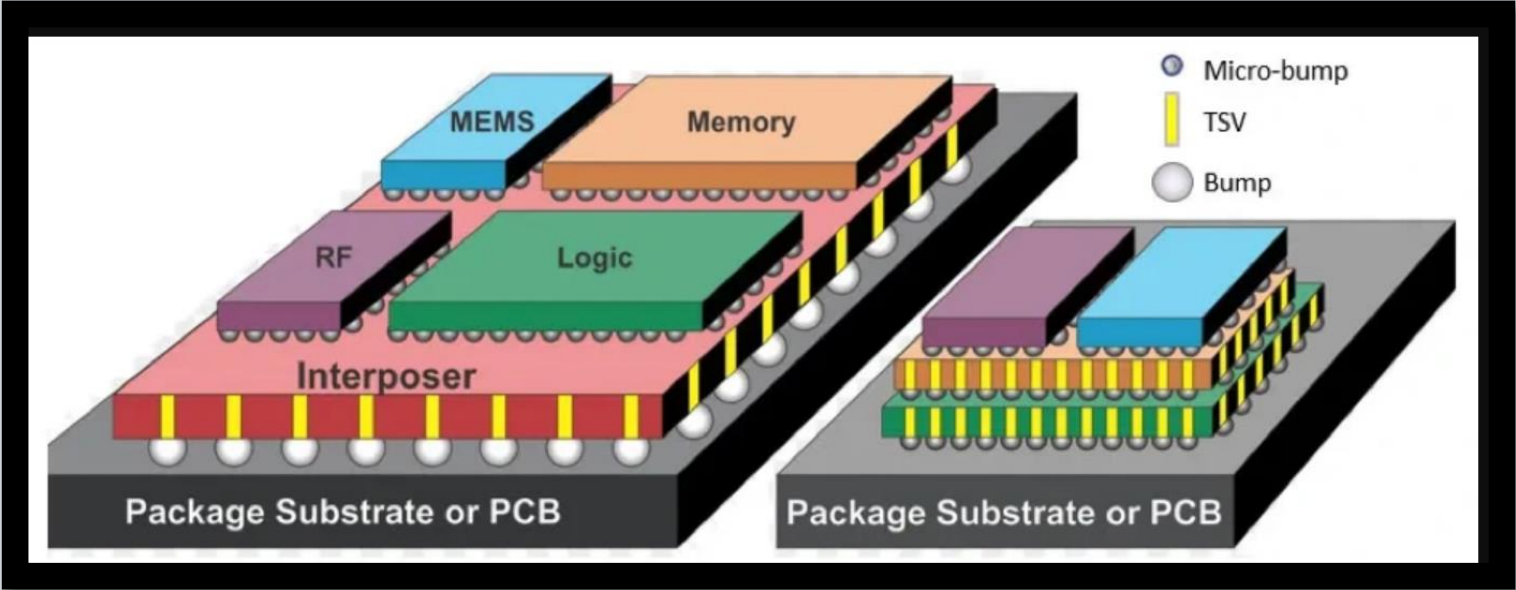

3D Architecture

**Demand for data requires more complex chip architecture.
Nordson's technologies play a key role.**

Medical and Fluid Solutions



Fluid Solutions
Precision Low-Volume Dispensing

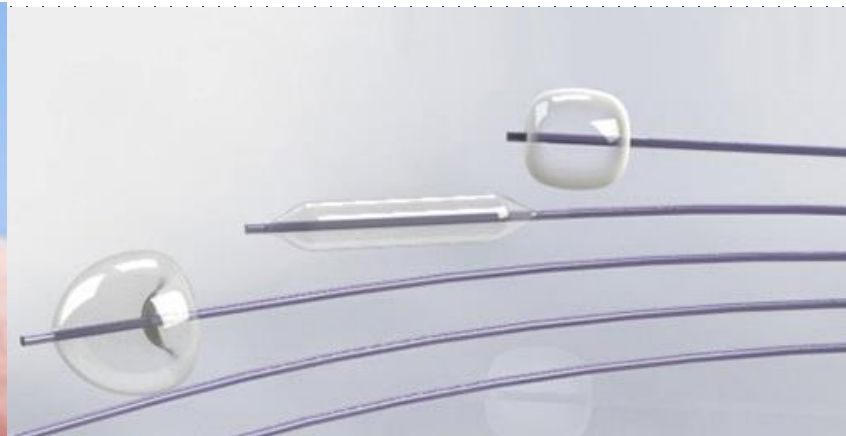

Interventional Solutions
Medical balloons, catheters, cannulas



Fluid Components
Single-use components

From benchtop dispensers to industry-best jetting valves and automated dispensing robots, Nordson fluid solutions systems deliver accurate, repeatable deposits of glues, greases, and other industrial fluids in precise, low-volume applications.

From specialty tubing, catheters, medical balloons, Nordson is an expert in the design, development and manufacture of complex medical devices and component technologies.

Proprietary single-use plastic connectors, stopcocks, valves, clamps, etc., used for patient care (IV's and blood pressure cuffs), biopharma and gene therapy applications.

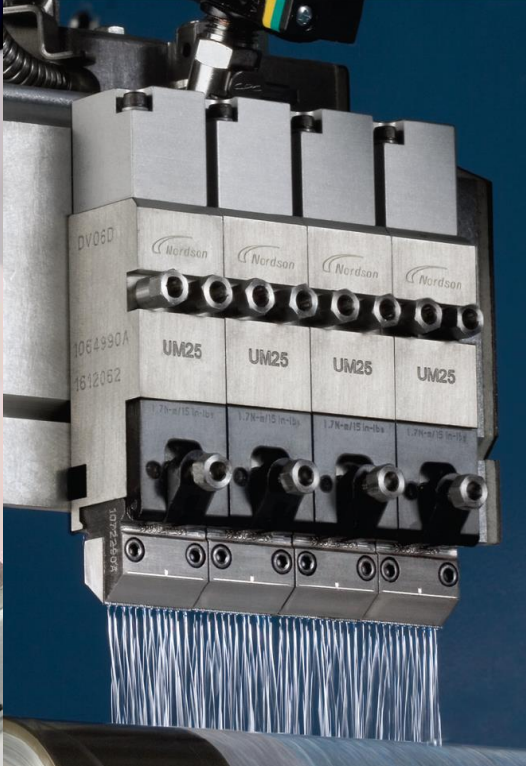
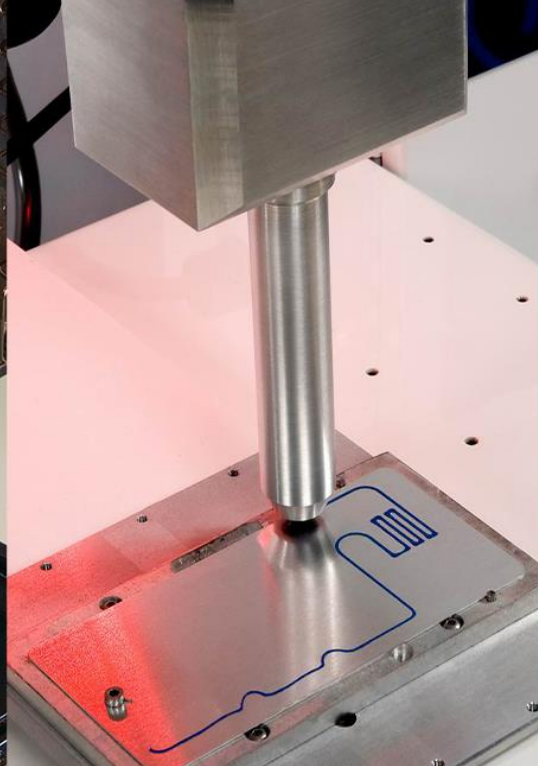

Core Adhesives Innovative Technology

Auto-fill Tankless Technology

Adhesive fill systems monitor and maintain optimum adhesive levels

Variable Dispense Technology

Delivering different add-on rates with one applicator

Foaming Technology

Maintains bond strength while reducing volume of adhesive required

Jetting Technology

Dispenses adhesive using non-contact jetting into channels as small as 0.3mm or 300 micron per second

Precision dispense technology

Increases production efficiency for nonwovens manufacturing process

Appendix 2:
Financial Exhibits

Non-GAAP Definitions

This presentation contains references to non-GAAP financial information. Although these are non-GAAP measures, we believe that they are useful to an investor in evaluating the company performance for the period presented. These non-GAAP definitions include:

- EBITDA is defined as operating profit plus certain adjustments, such as severance, fees and non-cash inventory charges associated with acquisitions, plus depreciation and amortization.
- Return on Invested Capital is defined as adjusted operating profit after tax as a percentage of the sum of average debt (net of cash) plus average shareholders' equity.
- Organic sales defined as sales growth excluding the impacts of changes in foreign currencies and acquisitions. We express period over period revenue variances as a percentage.
- Free cash flow is defined as cash flow provided by operating activities less additions to property, plant and equipment.
- Net debt is defined as total long-term debt less cash and cash equivalents.

Amounts may be rounded.

See the company's earnings release for the third quarter ended July 31, 2024, for a reconciliation of the non-GAAP measures Adjusted Operating Profit and EBITDA.

Reconciliation of Non-GAAP Measures



Net Income to Adjusted EBITDA (Dollars in thousands)

NORDSON CORPORATION

RECONCILIATION OF NON-GAAP MEASURES - NET INCOME TO EBITDA (Unaudited) (Dollars in thousands)

	Three Months Ended		Nine Months Ended	
	July 31, 2024	July 31, 2023	July 31, 2024	July 31, 2023
Net income	\$ 117,327	\$ 127,891	\$ 345,116	\$ 359,715
Income taxes	32,107	34,161	92,293	95,044
Interest expense - net	17,776	11,486	56,729	30,904
Other expense - net	(152)	(2,542)	971	2,059
Depreciation and amortization	33,382	27,102	99,646	80,637
Inventory step-up amortization ⁽¹⁾	—	—	2,944	4,306
Severance and other	2,536	2,049	4,615	5,487
Acquisition-related costs ⁽¹⁾	5,160	7,732	5,757	13,721
EBITDA (non-GAAP) ⁽²⁾	\$ 208,136	\$ 207,879	\$ 608,071	\$ 591,873

⁽¹⁾ Represents fees, severance and non-cash inventory charges associated with acquisitions.

⁽²⁾ EBITDA is a non-GAAP measure used by management to evaluate the Company's ongoing operations. EBITDA is defined as operating profit plus certain adjustments, such as severance, fees and non-cash inventory charges associated with acquisitions, plus depreciation and amortization.

Reconciliation of Non-GAAP Measures



Adjusted Operating Profit and EBITDA (Dollars in thousands)

NORDSON CORPORATION
RECONCILIATION OF NON-GAAP MEASURES - EBITDA (Unaudited)
(Dollars in thousands)

	Three Months Ended		Nine Months Ended	
	July 31, 2024	July 31, 2023	July 31, 2024	July 31, 2023
SALES BY SEGMENT				
Industrial Precision Solutions	\$ 370,561	\$ 338,257	\$1,092,099	\$ 985,610
Medical and Fluid Solutions	166,737	170,871	495,229	491,683
Advanced Technology Solutions	124,306	139,549	358,111	432,026
Total sales	<u>\$ 661,604</u>	<u>\$ 648,677</u>	<u>\$1,945,439</u>	<u>\$1,909,319</u>
OPERATING PROFIT				
Industrial Precision Solutions	\$ 118,110	\$ 115,346	\$ 344,305	\$ 329,439
Medical and Fluid Solutions	48,374	54,019	143,467	141,326
Advanced Technology Solutions	22,945	27,083	60,767	70,136
Corporate	(22,371)	(25,452)	(53,430)	(53,179)
Total operating profit	<u>\$ 167,058</u>	<u>\$ 170,996</u>	<u>\$ 495,109</u>	<u>\$ 487,722</u>
OPERATING PROFIT ADJUSTMENTS ⁽¹⁾				
Industrial Precision Solutions	\$ 2,536	\$ —	\$ 6,077	\$ —
Medical and Fluid Solutions	—	—	—	1,479
Advanced Technology Solutions	—	2,049	2,078	14,303
Corporate	5,160	7,732	5,161	7,732
Total adjustments	<u>\$ 7,696</u>	<u>\$ 9,781</u>	<u>\$ 13,316</u>	<u>\$ 23,514</u>
DEPRECIATION & AMORTIZATION				
Industrial Precision Solutions	\$ 14,521	\$ 7,036	\$ 42,821	\$ 21,166
Medical and Fluid Solutions	13,553	14,133	40,822	41,441
Advanced Technology Solutions	3,368	3,834	10,093	11,656
Corporate	1,940	2,099	5,910	6,374
Total depreciation & amortization	<u>\$ 33,382</u>	<u>\$ 27,102</u>	<u>\$ 99,646</u>	<u>\$ 80,637</u>
EBITDA (NON-GAAP) ⁽²⁾				
Industrial Precision Solutions	\$ 135,167	36% \$ 122,382	36% \$ 393,203	36% \$ 350,605
Medical and Fluid Solutions	61,927	37% 68,152	40% 184,289	37% 184,246
Advanced Technology Solutions	26,313	21% 32,966	24% 72,938	20% 96,095
Corporate	(15,271)	(15,621)	(42,359)	(39,073)
Total EBITDA	<u>\$ 208,136</u>	31% <u>\$ 207,879</u>	32% <u>\$ 608,071</u>	31% <u>\$ 591,873</u>

⁽¹⁾ Represents severance as well as fees and non-cash inventory charges associated with acquisitions.

⁽²⁾ EBITDA is a non-GAAP measure used by management to evaluate the Company's ongoing operations. EBITDA is defined as operating profit plus certain adjustments, such as severance, fees and non-cash inventory charges associated with acquisitions, plus depreciation and amortization.

Reconciliation of Non-GAAP Measures

Profitability (Dollars in thousands)



NORDSON CORPORATION
RECONCILIATION OF NON-GAAP MEASURES - ADJUSTED NET INCOME AND EARNINGS PER SHARE
(Unaudited)
(Dollars in thousands)

	Three Months Ended		Nine Months Ended	
	July 31, 2024	July 31, 2023	July 31, 2024	July 31, 2023
GAAP AS REPORTED				
Operating profit	\$ 167,058	\$ 170,996	\$ 495,109	\$ 487,722
Other / interest expense - net	(17,624)	(8,944)	(57,700)	(32,963)
Net income	117,327	127,891	345,116	359,715
Diluted earnings per share	\$ 2.04	\$ 2.22	\$ 5.99	\$ 6.24
Shares outstanding - diluted	57,624	57,530	57,620	57,657
OPERATING PROFIT ADJUSTMENTS				
Inventory step-up amortization	\$ —	\$ —	\$ 2,944	\$ 4,306
Acquisition-related costs	5,160	7,732	5,757	13,721
Severance and other	2,536	2,049	4,615	5,487
ACQUISITION AMORTIZATION OF INTANGIBLES				
	\$ 19,202	\$ 13,922	57,412	41,839
Total adjustments	<u>\$ 26,898</u>	<u>\$ 23,703</u>	<u>\$ 70,728</u>	<u>\$ 65,353</u>
Adjustments net of tax	\$ 21,134	\$ 18,706	\$ 55,804	\$ 51,694
EPS effect of adjustments and other discrete tax items	\$ 0.37	\$ 0.33	\$ 0.97	\$ 0.90
NON-GAAP MEASURES-ADJUSTED NET INCOME AND ADJUSTED EARNINGS PER SHARE				
Adjusted Net income ⁽¹⁾	\$ 138,461	\$ 146,597	\$ 400,920	\$ 411,409
Adjusted Diluted earnings per share ⁽²⁾	\$ 2.41	\$ 2.55	\$ 6.96	\$ 7.14

⁽¹⁾ Adjusted net income is a non-GAAP measure defined as net income plus tax effected adjustments and other discrete tax items.

⁽²⁾ Adjusted earnings per share is a non-GAAP measure defined as GAAP EPS adjusted for tax effected adjustments and other discrete tax items.

Management uses certain non-GAAP measures, such as adjusted net income, adjusted EPS and EBITDA, internally to make strategic decisions, forecast future results, and evaluate the Company's current performance. Given management's use of these non-GAAP measures, the Company believes these measures are important to investors in understanding the Company's current and future operating results as seen through the eyes of management. In addition, management believes these non-GAAP measures are useful to investors in enabling them to better assess changes in the Company's core business across different time periods. Because non-GAAP financial measures are not standardized, it may not be possible to compare these financial measures to other companies' non-GAAP financial measures, even if they have similar names. Amounts may not add due to rounding.

Reconciliation of Non-GAAP measures

Operating Cash Flow to Free Cash Flow

NORDSON CORPORATION

RECONCILIATION OF NON-GAAP MEASURES - OPERATING CASH FLOW TO FREE CASH FLOW

(Unaudited)

(Dollars in thousands)

	Year to Date		
	July 31, 2024	April 30, 2024	January 31, 2024
Net cash provided by operating activities	\$ 459,812	\$ 294,964	\$ 172,356
Additions to property, plant and equipment	(43,786)	(21,907)	(7,530)
Free Cash Flow - Year to Date ⁽¹⁾	416,026	273,057	164,826
Free Cash Flow - Quarter to Date ⁽²⁾	142,969	108,231	164,826

	Year to Date		
	July 31, 2023	April 30, 2023	January 31, 2023
Net cash provided by operating activities	478,072	\$ 287,905	\$ 123,337
Additions to property, plant and equipment	(24,244)	(15,349)	(9,302)
Free Cash Flow ⁽¹⁾	453,828	272,556	114,035
Free Cash Flow - Quarter to Date ⁽²⁾	181,272	158,521	114,035

⁽¹⁾ Free Cash Flow - Year to Date is a non-GAAP measure used by management to evaluate the Company's ongoing operations and is defined as Net cash provided by operating activities minus Additions to property, plant and equipment.

⁽²⁾ Free Cash Flow - Quarter to Date is a non-GAAP measure used by management to evaluate the Company's ongoing operations and is equal to Free Cash Flow - Year to Date less prior period Free Cash Flow - Year to Date.