



NASDAQ: SKYYX

MAKING

Homes & Buildings

Safe, Smart & Advanced

THE NEW STANDARD

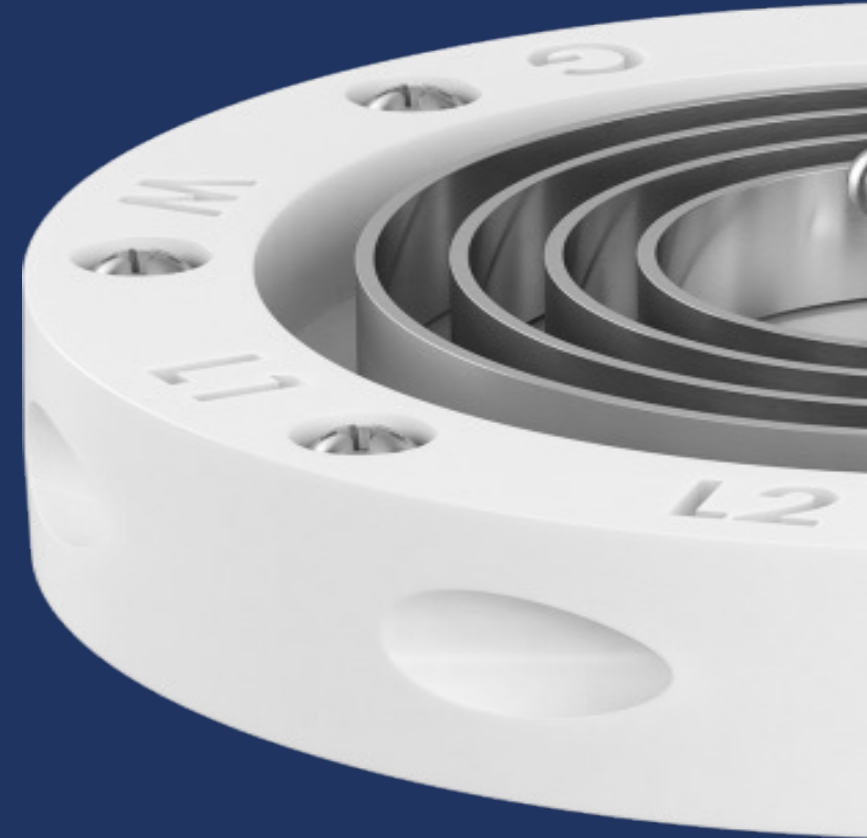

Cautionary Statements



This presentation has been prepared by SKYX Platforms Corp. (d/b/a Sky Technologies) (the "Company") solely for informational purposes based on its own information, as well as information from public sources. This presentation has been prepared to assist interested parties in completing their own evaluation of the Company and does not purport to contain all of the information that may be relevant. In all cases, interested parties should conduct their own investigation and analysis of the Company and the data set forth in the presentation and any other information provided by or on behalf of the Company. This presentation does not constitute an offer to sell, nor a solicitation of an offer to buy, any securities of the Company by any person in any jurisdiction in which it is unlawful for such person to make such an offering or solicitation. Neither the Securities and Exchange Commission nor any other regulatory body has approved or disapproved of the securities of the Company or passed upon the accuracy or adequacy of this presentation. Any representation to the contrary is a criminal offense.

Except as otherwise indicated, this presentation speaks as of the date hereof. The delivery of this presentation shall not, under any circumstances, create any implication that there has been no change in the affairs of the Company after the date hereof. The Company anticipates that subsequent events and developments will cause its views to change; however, it undertakes no obligation to publicly update any forward-looking statements, whether as a result of new information, future events or otherwise, except as required by U.S. federal securities laws. You should, therefore, not rely on these forward-looking statements as representing the Company's views as of any date subsequent to the date of this presentation.

Certain of the information contained herein may be derived from information provided by industry sources. The Company believes that such information is accurate and that the sources from which it has been obtained are reliable. The Company cannot guarantee the accuracy of such information and has not independently verified such information.

Certain statements contained in this presentation constitute forward-looking statements. Management has based these forward-looking statements on its current expectations, assumptions, estimates and projections. While they believe these expectations, assumptions, estimates and projections are reasonable, such forward-looking statements are only predictions and involve known and unknown risks and uncertainties, many of which are beyond management's control. These statements involve risks and uncertainties that may cause the Company's actual results, performance or achievements to differ materially from any future results, performance or achievements expressed or implied by these forward-looking statements. Our estimates of the addressable market for our products may prove to be incorrect. The projected demand for our products could materially differ from actual demand. Forward-looking statements speak only as of the date they are made and include statements relating to the Company's ability to successfully launch, commercialize, develop additional features and achieve market acceptance of its smart products and technologies, including commencement of presales, the Company's efforts and ability to drive the adoption of Sky's Plug Smart Platforms into multi-family residential buildings and communities and adoption by hotels, ability to capture market share, ability to execute on any sales and licensing opportunities, ability to achieve code mandatory status for the SkyPlug, and other risks and uncertainties described in the Company's filings with the Securities and Exchange Commission. In particular, the NEC's approval of the Company's generic names for its weight-bearing safe plug & play outlet/receptacle for ceilings as WSCR (Weight-Supporting Ceiling Receptacle) for its universal ceiling outlet and WSAF (Weight-Supporting Attachment Fitting) for its ceiling plug, or the American National Standards Institute's (ANSI) and the National Electrical Manufacturers Association's (NEMA) vote for the standardization of the Company's weight-bearing plug and outlet/receptacle for ceilings, does not guarantee approval by the National Fire Protection Association's (NFPA) Committee on the National Electrical Code (which consists of multiple code-making panels and a technical correlating committee and develops the National Electrical Code (NEC)) or any other trade or regulatory organization and does not guarantee that any of the Company's products will become National Electrical Code (NEC)-code mandatory in any jurisdiction, or that any of the Company's current or future products or technologies will be adopted by any state, country, or municipality, within any specific timeframe or at all. There can be no assurance as to any of these matters. Readers are cautioned not to put undue reliance on forward-looking statements, and, except as required by law, the Company assumes no obligation and does not intend to update or revise these forward-looking statements, whether as a result of new information, future events, or otherwise. Additional risk factors are included in the Company's annual report on Form 10-K and its subsequent filings with the Securities and Exchange Commission.

The Company's first-generation technologies enable light fixtures, ceiling fans and other electrically wired products to be installed safely and plugged in to a ceiling's electrical outlet box within seconds, and without the need to touch hazardous wires. The plug and play technology method is a universal power-plug device that has a matching receptacle that is connected to the electrical outlet box on the ceiling, enabling a safe and quick plug and play installation of light fixtures and ceiling fans in just seconds. In recent years, the Company has developed prototypes that expand the capabilities of its power-plug product, to include advanced safe and quick universal installation methods, as well as advanced smart capabilities, which are currently in the third and final prototype stage prior to launching. The smart features contained in the final prototype include control of light fixtures and ceiling fans by the SkyHome App, through WIFI, Bluetooth Low Energy and voice control connections. The Company's second-generation technology, which is in the second stage prototype, is an all-in-one safe and smart advanced platform (the "Smart Sky Platform") that is designed to enhance all-around safety and lifestyle of homes and other buildings. While the Company has developed and created working prototypes of its advanced and smart products, it is continuing to refine the product prototypes and expects to begin commercial manufacturing and marketing in the second half of 2022 for the advanced products and the smart universal power-plug, ceiling fans and lighting products and for the Smart Sky Platform. The Company cannot provide any assurance that it will be able to successfully launch its new products and technologies in its anticipated timeline, or at all, or that it will be able to integrate its products and technologies with third-party products and technologies, further develop them to include new features and to respond to customer demands, or otherwise realize its product strategy. In addition, the Company's estimates of the addressable market for its products may prove to be incorrect, and the projected demand for the Company's products could materially differ from actual demand. Even if the total addressable market for the Company's products is as large as it has estimated and even if it is able to gain market awareness and acceptance, the Company may not be able to penetrate the existing market to capture additional market share.

The Company's future plans include offering subscription services as part of its Smart Sky Platform, including, among other services, communications, fire alarms, home intrusion alerts, emergency response services and monitoring services. The smart platform will include, among other features, a smart smoke detector, a smart carbon monoxide detector, and a WIFI extender. The Company intends to expand its operations to enable it to provide services relating to these functions, including high-speed internet services, monitoring systems designed to sense movement, smoke, fire, carbon monoxide, temperature, and other environmental conditions and hazards, monitor home access and visitors and address personal emergencies such as injuries and other medical emergencies. The Company's ability to provide such services will depend on a variety of factors, including, but not limited to, subscriber interest and financial resources, any applicable licensing and regulatory compliance, the Company's ability to manage its anticipated expansion and to hire, train and retain personnel, and general economic conditions. The Company may partner with other businesses to provide such services. The Company expects to begin providing such services in 2023, but cannot provide any assurance that it will be able to do so.

Our Team Includes Key U.S. and Global Leaders



Our Management, Board, Advisory Team and Investors include U.S. and world leading members from a variety of industries



Rani Kohen
SKYX
Founder and Executive Chairman

Business Leader, Entrepreneur And Inventor



Steve Schmidt
SKYX President
Former CEO of Nielsen
DATA/Rating Corporation and President of Office Depot International



Bob Nardelli
SKYX Senior Advisor

Former CEO of Home Depot, Chrysler, and GE Power Systems



Al Wiess
SKYX Senior Advisor

Former President of Disney Worldwide Parks, Hotels, Resorts, Cruise Ships, and Products

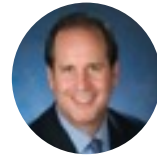

Lenny Sokolow
SKYX Co-CEO And Board Member
Former President of National Securities and CEO of Newbridge Securities



Governor Tom Ridge
SKYX Lead Director of SKYX's Board.
Former **Head of Homeland Security and Two times Governor Of Pennsylvania**



Lance Shaner
Chair of SKYX's Hotel Advisory Board
Owner of a Global Chain Of Hotels And Energy Industry Companies



Mark Earley
SKYX Head of Code /Standards.
Former Head of the National Electrical Code (NEC) And Chief Engineer of the NFPA retired after 33 years and joined SKYX



Eric Jacobson
SKYX Co-Head of Code /Standards.
Former President/CEO of the **American Lighting Association (ALA)** retired after 30 years and joined SKYX



Khadija Mustafa
SKYX Senior Tech Advisor

Former Microsoft Global AI and Business Leader retired after 23 years and joined SKYX



Paul Chernawsky
Chair of SKYX Insurance Advisory Board

Founder of Endurance E&Y entrepreneur of the year 2017



Patty Barron
COO Of SKYX
Founder & President of LTG Services, company focused on safety services for compliance of electrical technologies

VIDEO LINK TO SKYX's Three Generations of Technology

[CLICK HERE TO WATCH VIDEO](#)



Financial Highlights

- **\$58.8 million in sales in 2023**
- **\$19 million in sales in Q-1 of 2024**
- **\$21.4 million in sales in Q-2 of 2024**
- **\$22.2 million in sales in Q-3 of 2024**
- **Prior to the completion of our \$11 million raise in October 2024, we reported \$13 million in cash, cash equivalents, restricted cash, available cash, and investments available for sale as of September 30, 2024.**
- **In October 2024, SKYX Secured \$11 million equity preferred stock investment representing \$2.00 per share of common stock with NO warrants, led by global Marriott Hotel chain (developer/owner of over 70 hotels) including significant insider investing by SKYX's President Steve Schmidt, invested \$500,000, Co-CEO Lenny Sokolow, invested \$250,000, and Co-CEO John Campi, invested \$250,000.**
- **Management anticipates the Company will become cash-flow positive during 2025**

Mission: To make homes and buildings SAFE and SMART and Advanced as The NEW Standard

Our Products Significantly:

Save **Lives** – Save **Cost** – Save **Time** – **Simplify** and **Advance**

- **Patents: Company has 97 Patents and Pending Applications with 36 issued patents in the U.S. and Globally including China, India, and Europe**
- **Company owns over 60 websites for lighting and home décor and utilizes its e-commerce platform of to educate and enhance its market penetration to both retail and professional segments.**
- **Company's total addressable market (TAM) in the U.S. of \$500 billion with over 4.2 billion ceiling applications in the U.S. alone. Expected revenue streams from retail and professional segments include product sales, royalties, licensing, subscription, monitoring, and sale of global country rights.**
- **The Company continues to grow its market penetration of its advanced and smart plug & play products and expects its products to be in close to 15,000 U.S. and Canadian homes by the end of 2024. Company expects its products to be in tens of thousands of homes in 2025.**
- **Company strongly believes its products can save many billions of dollars annually to insurance companies, by reducing fires, ladder falls, electrocutions, among others. Management expects that once it completes an entire range and variations of its safe plug & play products it will start being recommended by insurance companies.**

Key Recent Collaborations

Key Collaborations with U.S. and World Leading Companies



SKYX and General Electric (GE) signed a 5-year global licensing partnership agreement to license SKYX's patented advanced and smart home platform technologies, including its ceiling outlet/receptacle related products as well as its all-in-one smart home platform technology



SKYX collaborates with Home Depot for Its Advanced and Smart Plug & Play Products for both retail and professional segments. SKYX's product offering will include a variety of its Advanced and Smart Plug & Play Products including Retrofit Kits, Smart Light Fixtures, Smart Ceiling Fans, Ceiling Outlet Receptacles, Recessed Lights and more



SKYX collaborates with Wayfair for Its Advanced and Smart Plug & Play Products for both retail and professional segments. SKYX's product offering will include a variety of its advanced and Smart Plug & Play products including Retrofit Kits, Smart Light Fixtures, Smart Ceiling Fans, Ceiling Outlet Receptacles, Recessed Lights and more



SKYX collaborates with world leading lighting company Kichler



SKYX collaborates with U.S. lighting leading company Quoizel, 100 years old lighting company



SKYX collaborates with European leading lighting company EGLO



SKYX collaborates with World Leading Chinese Lighting Supplier and Manufacturer Ruee Appliances for the U.S., Chinese, and European Markets. The collaboration provides SKYX substantial backing in several segments including financial, mass production manufacturing capabilities, and distribution to global markets

Our Technologies Advance Key Sectors



Our Management and Leadership Strongly Believe that the Company is positioned to revolutionize both the lighting and smart home industries and can become a safety standard in homes and buildings in the U.S. and globally.

- **Electrical and Building Safety Regulators:** Will advance safety in homes and buildings
- **Insurance Companies:** Significant dollar savings for Insurance companies
- **Lighting industry:** Will save cost, will significantly reduce fixture replacement cycle, and increase sales
- **Smart home industry:** Will save significant cost and increase adoption
- **Electrical Outlet Box manufactures:** Will significantly increase sales and profits
- **Builders:** Significant Cost and time saving, while enhancing buildings safety
- **Apartment Buildings:** Significant Cost and time saving, while enhancing buildings safety
- **Hotels:** Significant Cost and time saving while enhancing buildings safety.
- **Cruise Industry:** Significant Cost and time saving, while enhancing ship safety.

OUR PRODUCTS SAVE INSURANCE COMPANIES BILLIONS OF \$\$\$

Revolutionizing The Lighting Industry

SAFE Plug & Play Lighting & Ceiling Fans

Sky Receptacle/Outlet

SAFE
PLUG & PLAY



SkyPlug

Revolutionizing The Lighting Industry

SMART SAFE Plug & Play Lighting & Ceiling Fans

Sky Receptacle/Outlet

SAFE
PLUG & PLAY



SkyPlug
SMART

Revolutionizing The Smart Home Industry

SMART HOME Plug & Play All-In-One PLATFORM

Makes Homes Become Smart in Just Minutes



App Control

- ✓ Apple Siri
- ✓ Amazon Alexa
- ✓ Google Home
- ✓ Samsung Bixby



Voice Control



SAFE
PLUG & PLAY

All-In-One SMART Home Platform

SKYX Wins SEVEN CES Awards



We have been awarded!

Some of the best organizations in the industry recognize us

Member of

- AMERICAN LIGHTING ASSOCIATION
- NEMA
- CONSUMER TECHNOLOGY ASSOCIATION
- WI-FI ALLIANCE
- BLUETOOTH SIG

Recognized by



Scan QR Code For More Information



Sky Platforms Corp. (Nasdaq: SKYX)



Safe Plug & Play

Plug & Play
Color Changing Smart Lighting Base



Retrofit Kit For Pendant & Chandelier

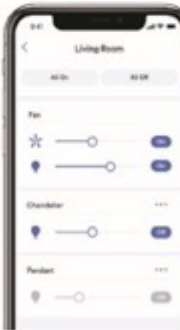

Color Changing



ANSI / NEMA WD-6 Specification Permitted by NEC



NEC
National Electrical Code

ANSI
American National Standards Institute

NEMA
National Electrical Manufacturers Association

AIA
American Institute of Architects

IAEI
International Association of Electrical Inspectors

SEVEN CES AWARDS

Equivalency of Concepts

BILLIONS OF PLUGS & RECEPTACLES

PROBLEM

Then
Hazardous
Wire
Installation



SOLUTION

Now
Safe
Plug & Play
Installation



BILLIONS OF LIGHT BULBS

PROBLEM

Then
Hazardous
Wire
Installation



Edison's
Bulb

SOLUTION

Now
Safe
Installation



BILLIONS OF Light FIXTURES

PROBLEM

Today
Wire Installation

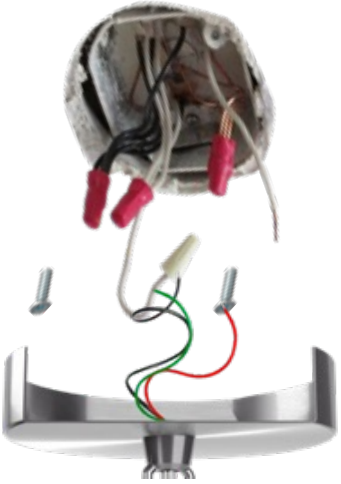

SOLUTION



The Future Is Here

Safe
Plug & Play
Installation



For Billions
Of Fixtures

PROBLEM

CEILING TODAY

Dangerous electrical wires

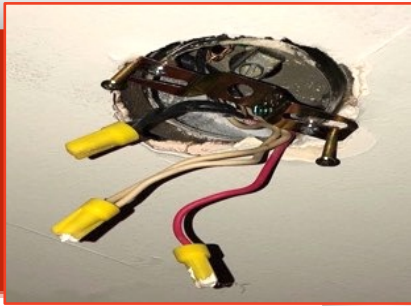

- Injuries
- Death
- Exposed live wires
- Touching live wires
- Shocks and Electrocutions
- Fires
- Shorts
- Falls from ladders due to loss of balance during installation and shocks

SOLUTION

CEILING TOMORROW

Safe Plug and Play CEILING OUTLET



- Eliminates the need to touch wires
- Eliminates exposed wires
- Reduces shocks and electrocutions
- Reduces fires due to incorrect wiring
- Reduces majority of time on ladders
- Reduces unsteadiness / loss of balance
- Reduces injuries
- Reduces deaths

Safe Plug & Play Install →



NEW CEILING OUTLET RECEPTACLE



Creating a New Electrical Ceiling Safety Standard

- **Hundreds of millions of U.S. Hazardous Wire Installations Annually**
- **Billions of Global Hazardous Wire Installations Annually**

- Touching Exposed live wires
- Shorts, Shocks and Electrocutions
- Fires
- Injuries
- Death

- Saves up to 90% of installation time and cost
- Saves approx. 90% of ladder time and touching wires
- Completely eliminates the need of touching ceiling electrical wires after the first installation

PROBLEM

Hazardous Wires



SOLUTION

SAFE PLUG & PLAY



SKY CEILING
OUTLET RECEPTACLE



SAFE
PLUG & PLAY



SkyPlug

- Safe Plug & Play
- Safety Double Locking Mechanism
- Each Lock Bearing tested for 200 lbs
- Specified to hold 50 lbs

Universal Ceiling Outlet Receptacle

Residential

- **4.2 Billion Applications In U.S. Homes/Buildings**
- **140 Million U.S. Homes**
- **Approx. 30 light fixtures per home/apartment Including common areas** (lobbies, corridors, emergency steps, parking garages, exterior, etc.)
- **140M x 30 = 4.2 Billion fixtures Installed in US homes**
- **Average of fixture replacement is 10 years**
- **420M U.S. fixture installs annually**

Commercial

- **Billions of Commercial Applications In U.S. including:**
- **Hotels**
- **Office buildings**
- **Restaurants**
- **Malls**
- **Hospitals**
- **Schools etc.**



SKYX is Opening a New World of Plug & Play Ceiling Products

NOW Every HOME Shall have a CEILING Outlet Receptacle

Every HOME has a WALL Outlet Receptacle



Making Homes & Buildings Smart Instantly!!!



RAZOR & BLADE MODEL

Create a SMART HOME IN MINUTES

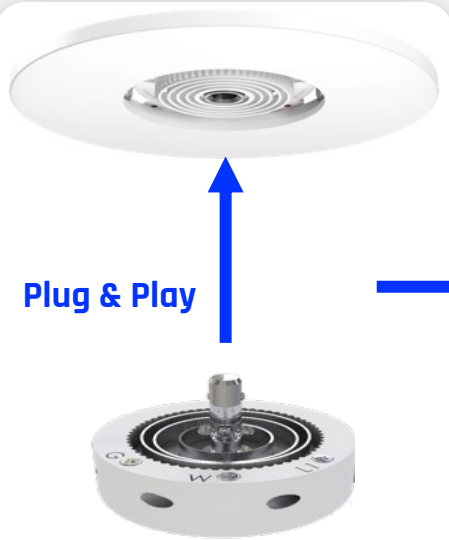

SMART HOME PACKAGES FOR

- Homes
- Buildings
- Hotels
- Commercial

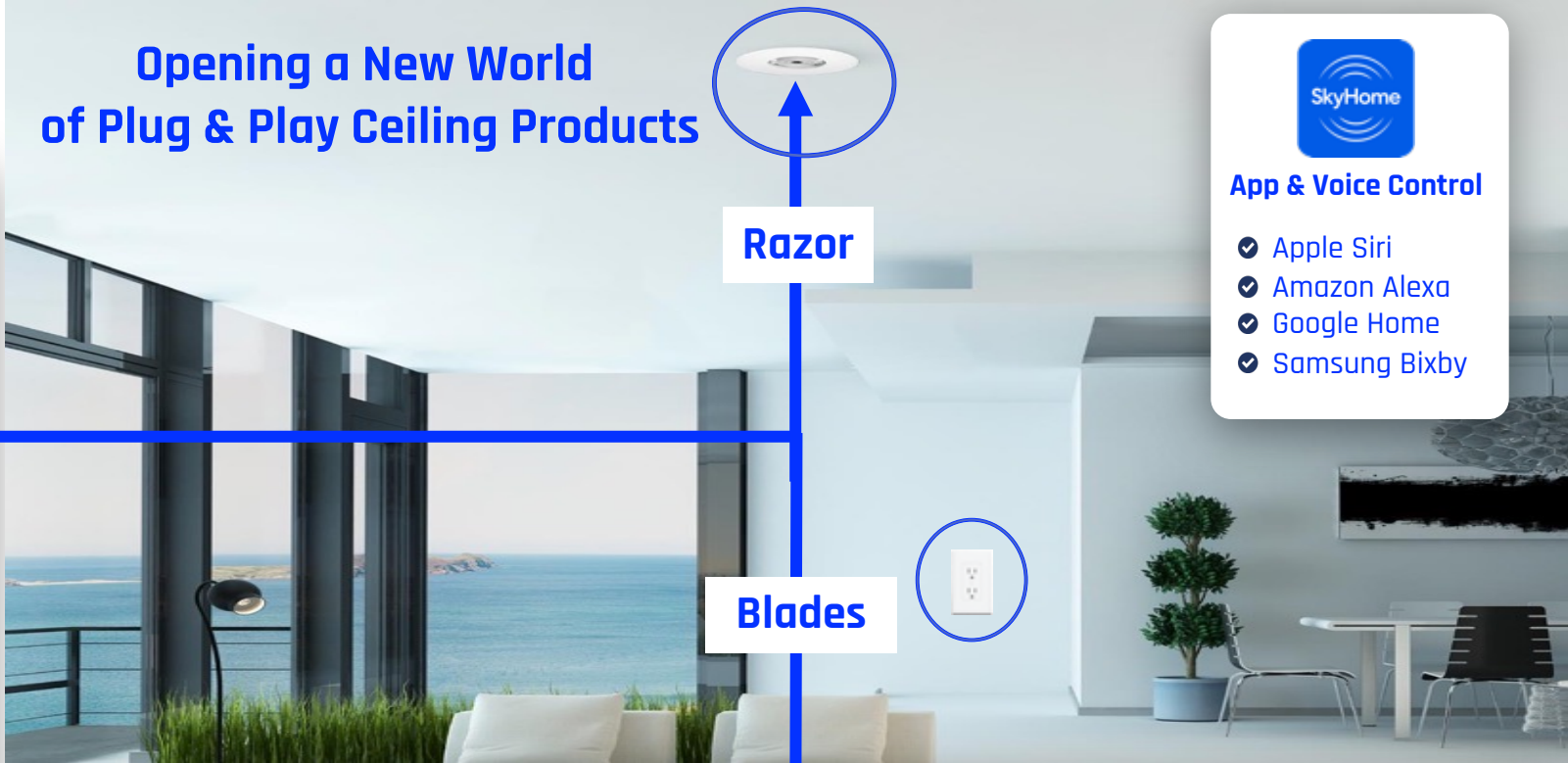

- Safe Plug & Play
- Safety Double Locking Mechanism
- Each Lock Bearing tested for 200 lbs
- Specified to hold 50 lbs

Opening a New World of Plug & Play Ceiling Products

App & Voice Control

- ✓ Apple Siri
- ✓ Amazon Alexa
- ✓ Google Home
- ✓ Samsung Bixby



Plug & Play Compatible Lighting & Fan Products



**OUR PRODUCTS
SAVE INSURANCE
COMPANIES
BILLIONS OF \$\$\$**



Plug & Play Installation

**Significantly Saves Lives,
Prevent Many Injuries and
Reduces :**

**Ladder Falls
Electrocutions
Fires from Electrical wires**

- Flush Mounts
- Recessed Lights
- Downlights
- Semi Flush
- EXIT/Emergency Lights



- Chandeliers
- Pendants
- Kids Lights
- Themes Lights
- Holiday Lights



- Ceiling Fans
- Fandeliers

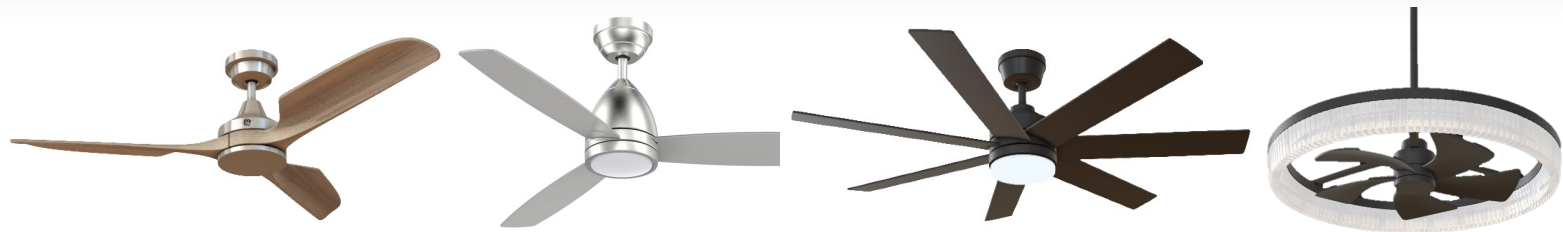

- Wall Sconces
- Bath Bars
- Outdoor Lanterns



PROBLEM INDIVIDUAL PRODUCTS

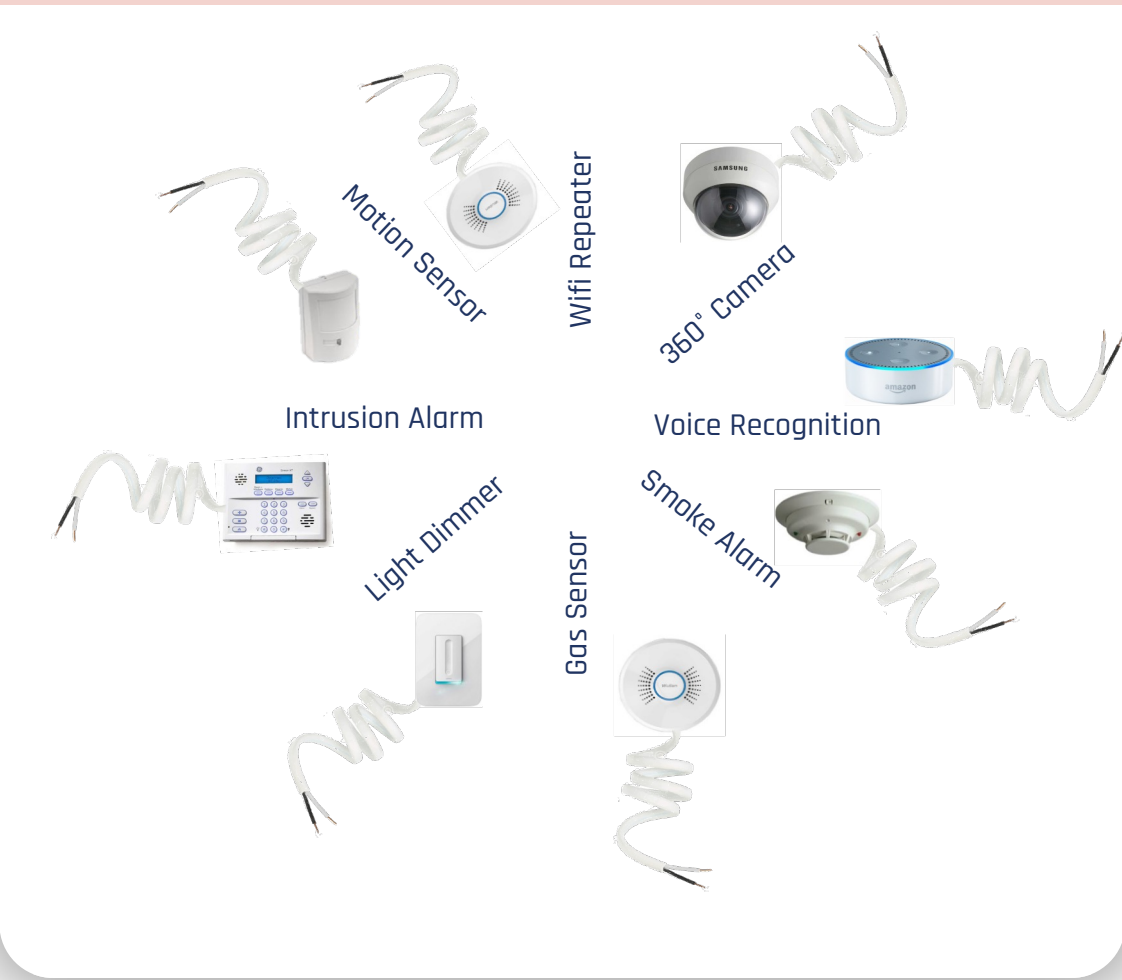

SOLUTION ALL-IN-ONE SMART HOME PLATFORM



Equivalency of Concepts

PROBLEM INDIVIDUAL PRODUCTS

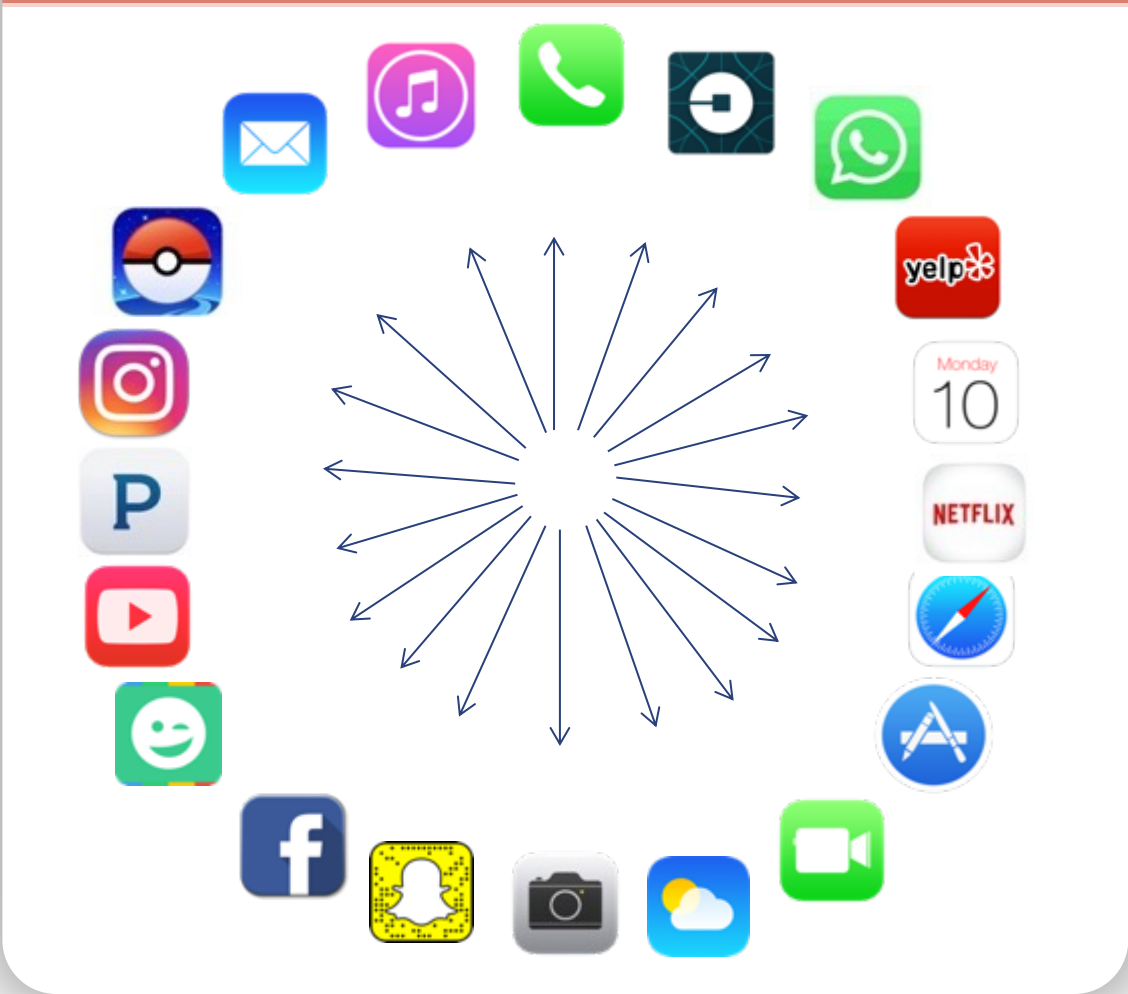

SOLUTION ALL-IN-ONE SMART PHONE PLATFORM

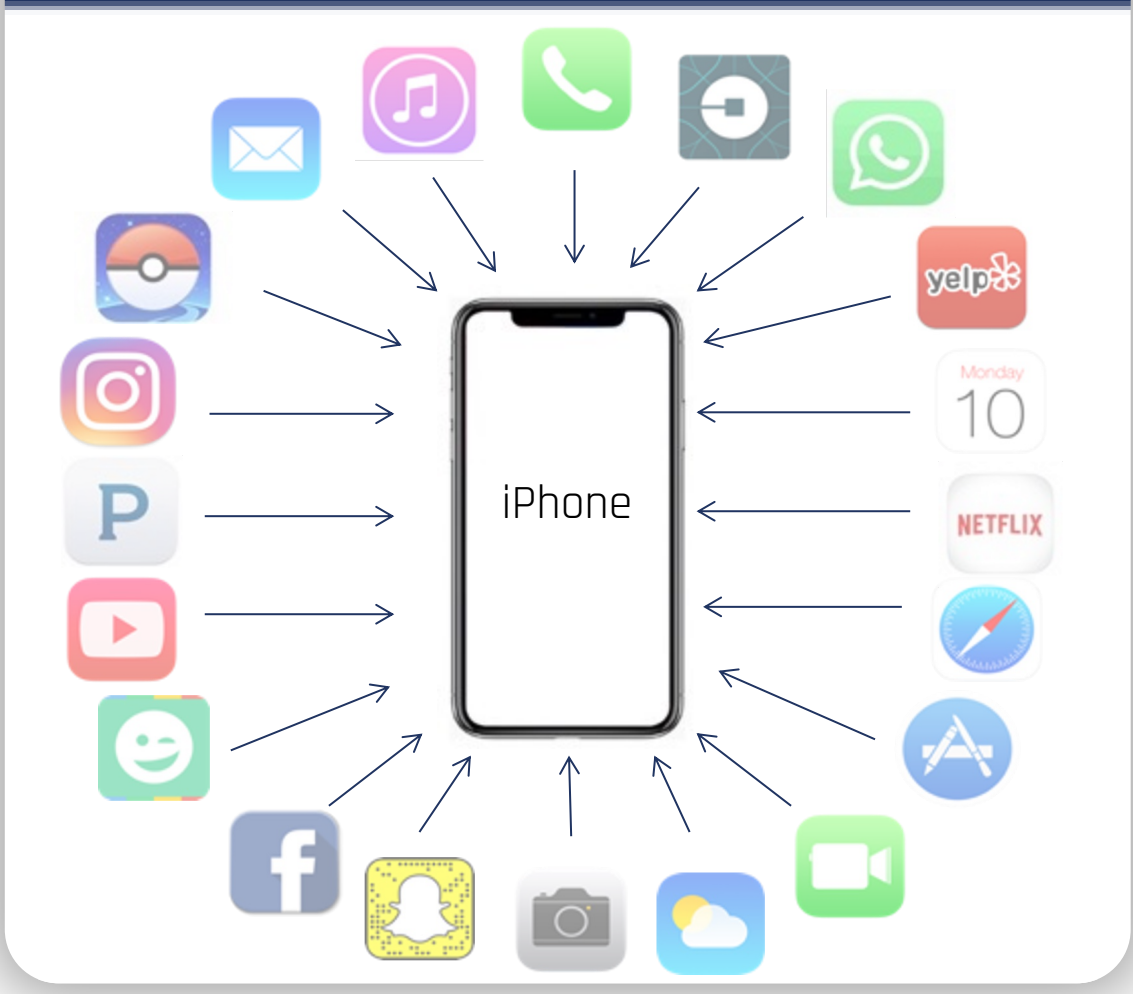

Plug & Play All-in-One Smart Home Platform

- **Ceiling Location Significantly Enhances Performance of Smart Home / Safety Products**
- **Implementing Existing Technologies into an All-In-One Platform**
- **Monitoring**
- **Subscriptions**
- **Data Aggregation**
- **Integrates with New & Existing Smart Products**
- **Management believes that in the future regulators and insurance companies will encourage SKYX'S Platform usage due to its safety features**

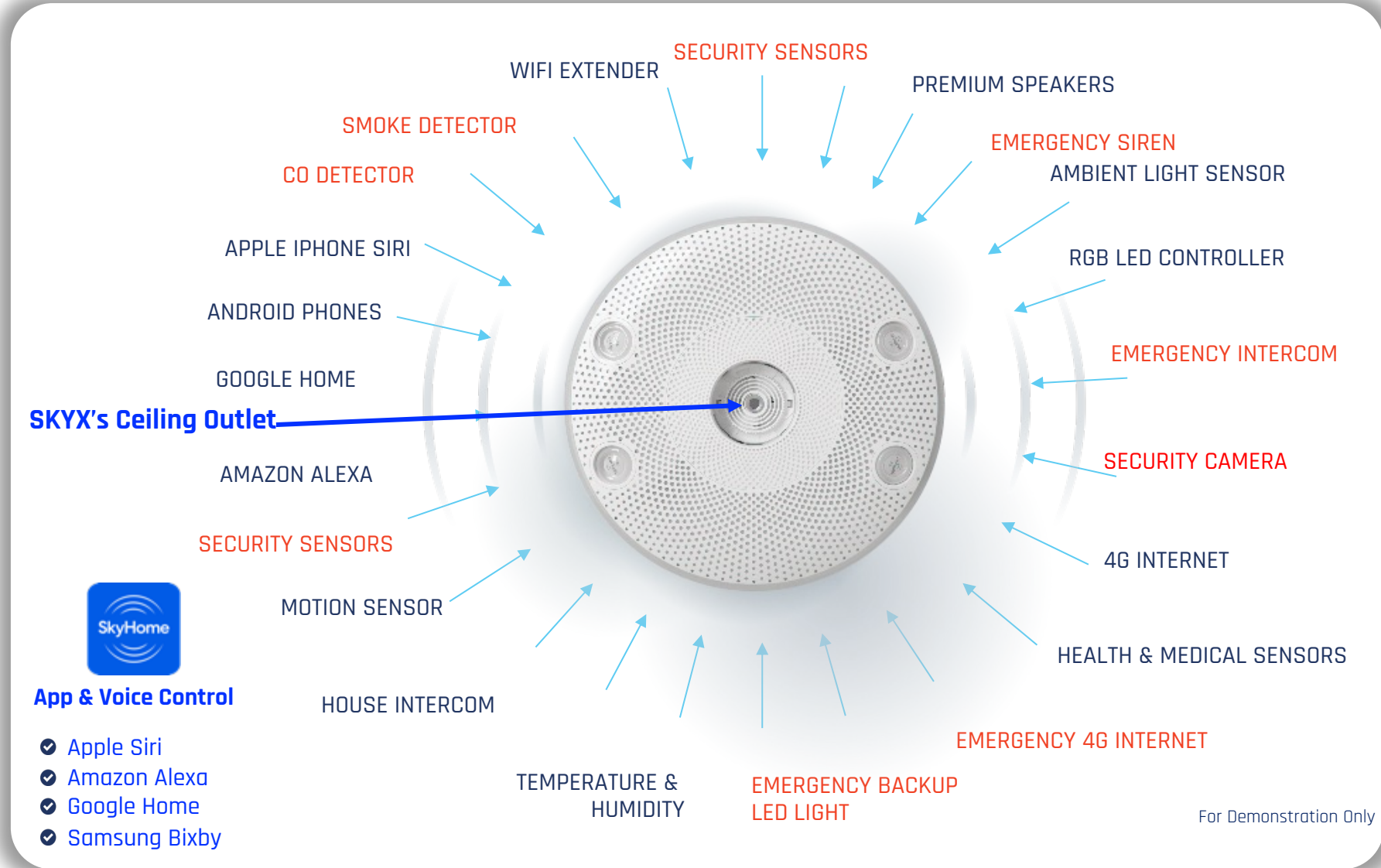

SKYX's Award Winning All-In-One Smart Home Platform



PROBLEM

TODAY: DAYS TO INSTALL, MULTIPLE Single Unit Devices, High Cost, Poor Performance

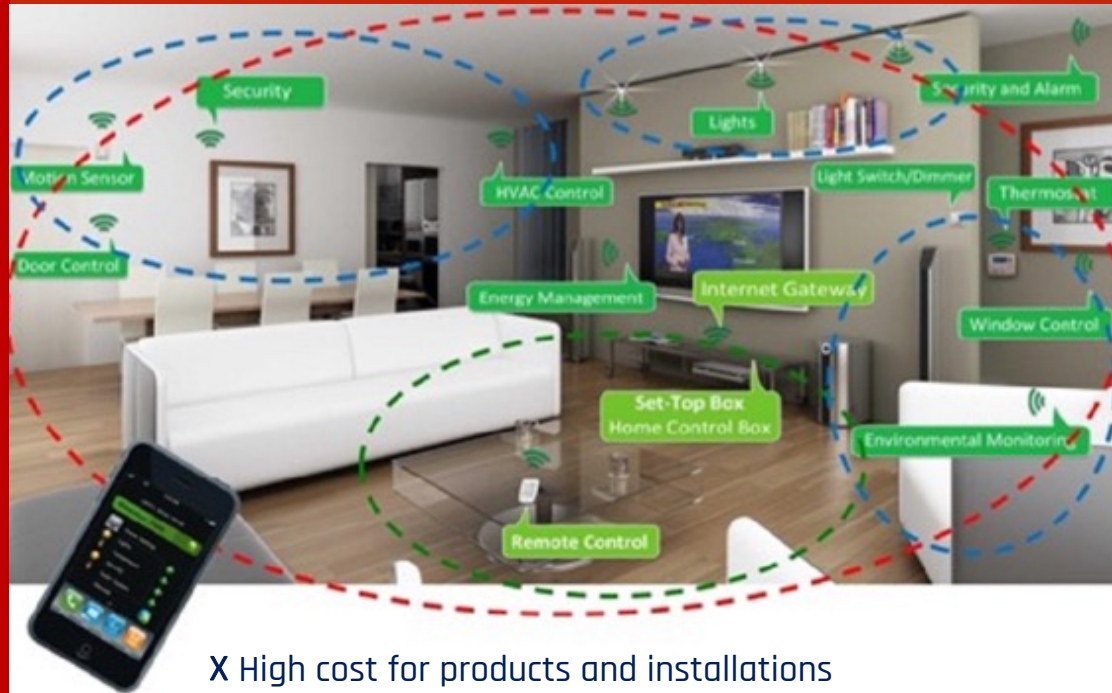

- X High cost for products and installations
- X Numerous single unit products/devices
- X Days for wiring and installations
- X Different frequencies for each product
- X Challenging product performance
- X Several disparate apps for multiple products

SOLUTION

TOMORROW: ALL-IN-ONE SMART PLATFORM, MINUTES TO INSTALL, Saves Cost, time, & Lives, Better Performance

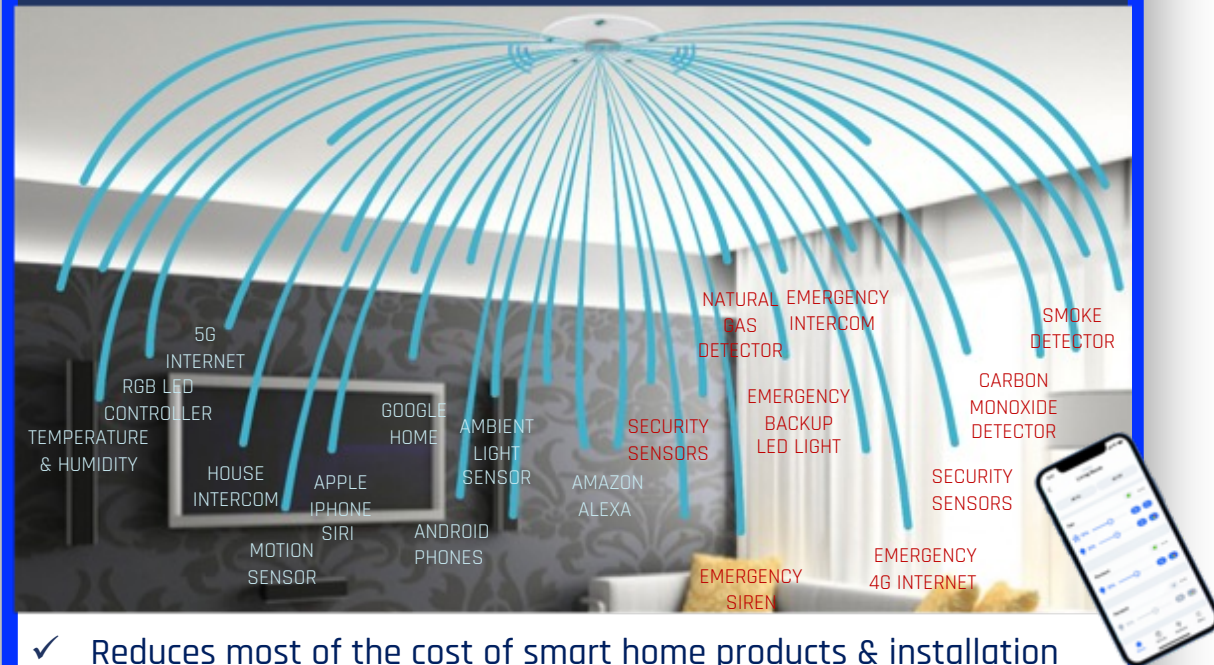

- ✓ Reduces most of the cost of smart home products & installation
- ✓ One product, All-In-One
- ✓ Minutes to install
- ✓ Great product performance
- ✓ One hub for all products
- ✓ Integrates with leading smart home technologies

Proprietary App
Phone & Voice Control

Works With

- ✓ Apple Siri
- ✓ Amazon Alexa
- ✓ Google Home
- ✓ Samsung Bixby



PROBLEM

LIMITED WIFI EXTENDER/ROUTER PERFORMANCE

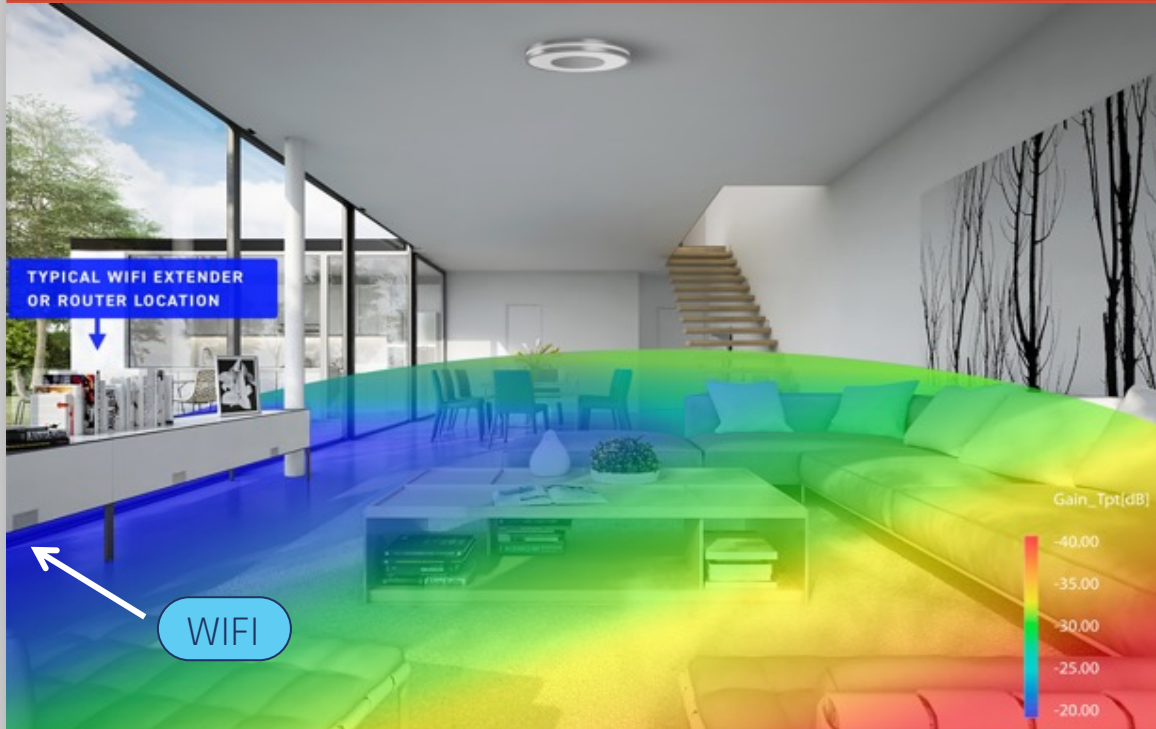

- Performance dependent on wall-based routers
- Extenders required

SOLUTION

SIGNIFICANTLY ENHANCING PERFORMANCE WIFI EXTENDER/ROUTER



Significantly Improves WIFI Speed and Range

Making Homes Safe & Smart in Minutes

1 of Sky's Smart Platform can make a 1-bedroom apartment Safe & Smart **IN MINUTES**, compared to existing technologies that can take days



With only minutes to install per room, Sky's Smart Platform can make **LARGE BUILDINGS AND HOTELS BECOME SAFE & SMART WITHIN DAYS**, compared to existing technologies that can take a year



With only minutes to install per room, Sky's Smart Platform can make a large home Safe & Smart **WITHIN JUST HOURS** compared to existing technologies that can take weeks

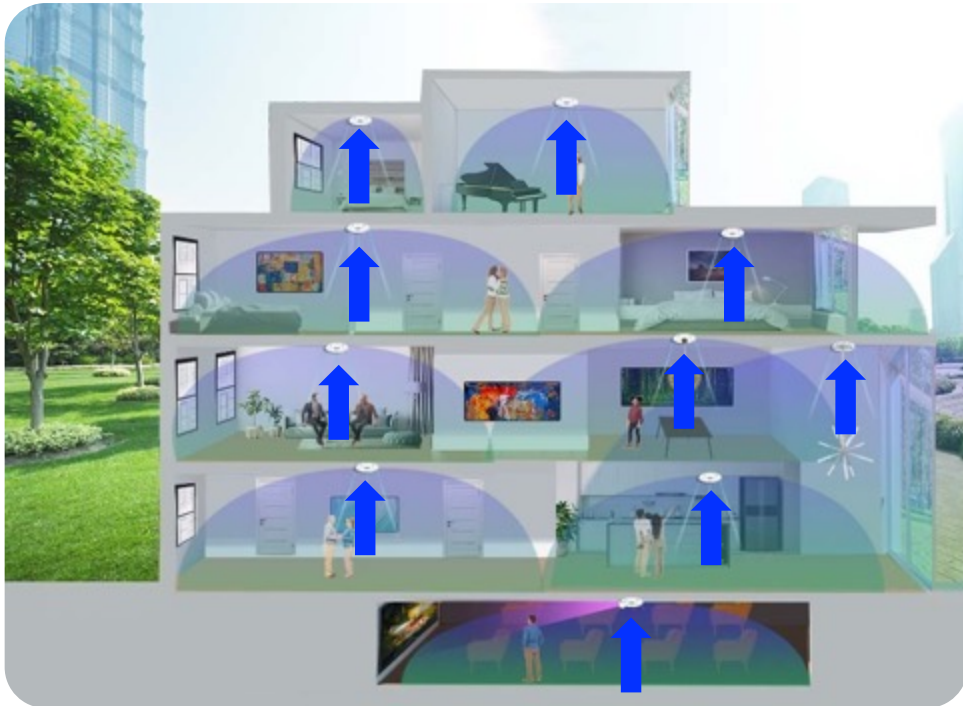

Making Every Room Safe & Smart as a Standard



Hotel Rooms

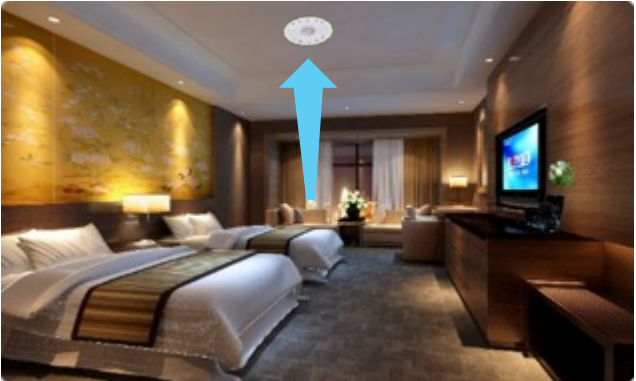

SAFETY SMART OTHER

Cruise Ships



SAFETY SMART OTHER

Hospitals - Elder Living



MEDICAL **SAFETY** SMART OTHER

Home Care



MEDICAL **SAFETY** SMART OTHER

Offices

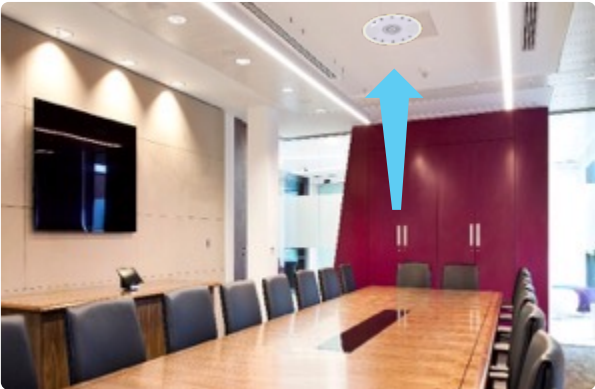

SAFETY SMART OTHER

Retail



SAFETY SMART OTHER



Generations 1 - 2 - 3

Go-To-Market

Time Consuming Hazardous Wire Installation

Creating A Purchase Barrier



- Time Consuming
- Coast Costuming
- Hazardous wire Installation

Safe Plug & Play

Enhancing Fixture Replacement

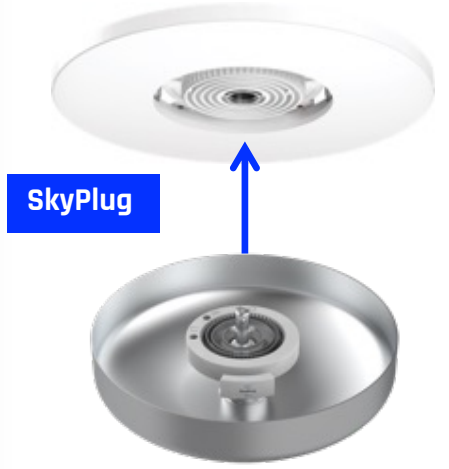

- Safe Plug & Play
- Double Safety Locking Mechanism
- Each Lock Bearing holds up to 200 lbs
- Specified for for 50 lbs

Safe & SMART Plug & Play



App & Voice Control

- Works With**
- ✔ Apple Siri
 - ✔ Amazon Alexa
 - ✔ Google Home
 - ✔ Samsung Bixby
- Smart Features**
- ✔ Phone control
 - ✔ WiFi/BLE
 - ✔ Voice control
 - ✔ Scheduling
 - ✔ Energy Saving mode
 - ✔ Dimming
 - ✔ Color changing
 - ✔ Night light
 - ✔ Emergency light
 - ✔ Power meter
 - ✔ Temperature
 - ✔ Humidity
 - ✔ And more

Enhancing Fixture Replacement



SkyPlug SMART

Voice Control App Control

SEVEN CES INNOVATION AWARDS AWARDS 23/34

Plug & Play Retrofit-Kits

Lighting Retrofit-Kits



Fan Retrofit-Kits

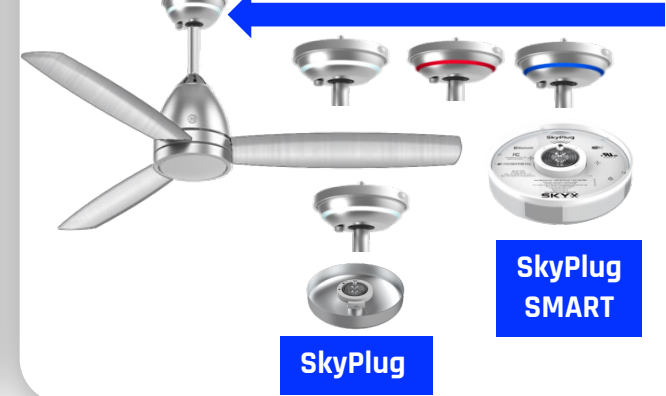

Plug & Play Recessed Light & Downlights

Same Base with Different Shape Frames in Multiple Colors

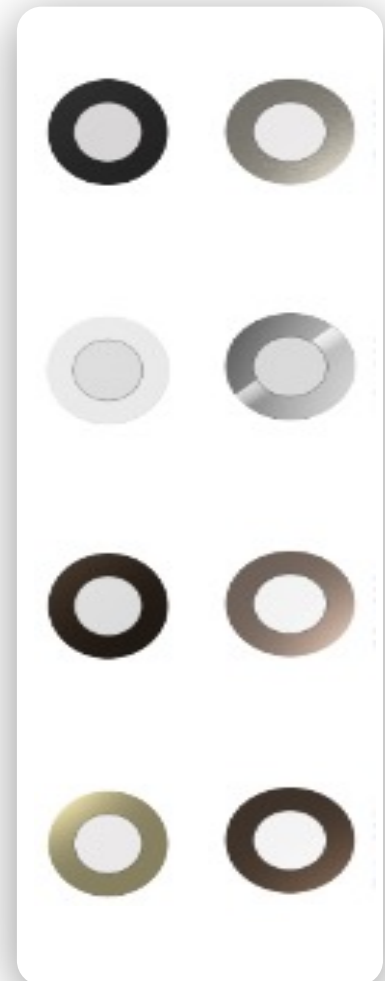
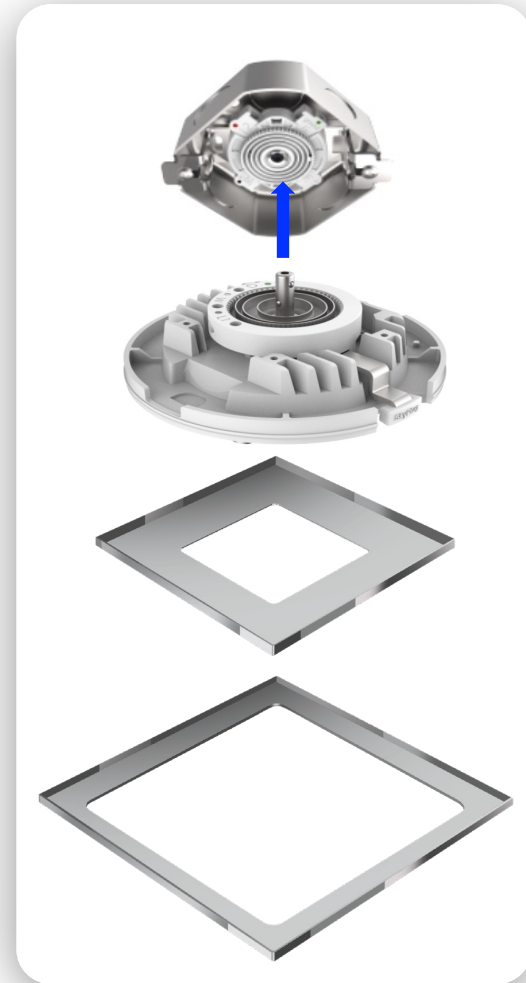

SMART SkyFan & Heater

SMART SkyFan & Heater

Good for All-Seasons

App & Voice Control

Works With

- ✓ Apple Siri
- ✓ Amazon Alexa
- ✓ Google Home
- ✓ Samsung Bixby

Smart Features

- ✓ Phone control
- ✓ WiFi/BLE
- ✓ Voice control
- ✓ Scheduling
- ✓ Energy Saving mode
- ✓ Dimming
- ✓ Color changing
- ✓ Night light
- ✓ Emergency light
- ✓ Power meter
- ✓ Temperature
- ✓ Humidity
- ✓ And more

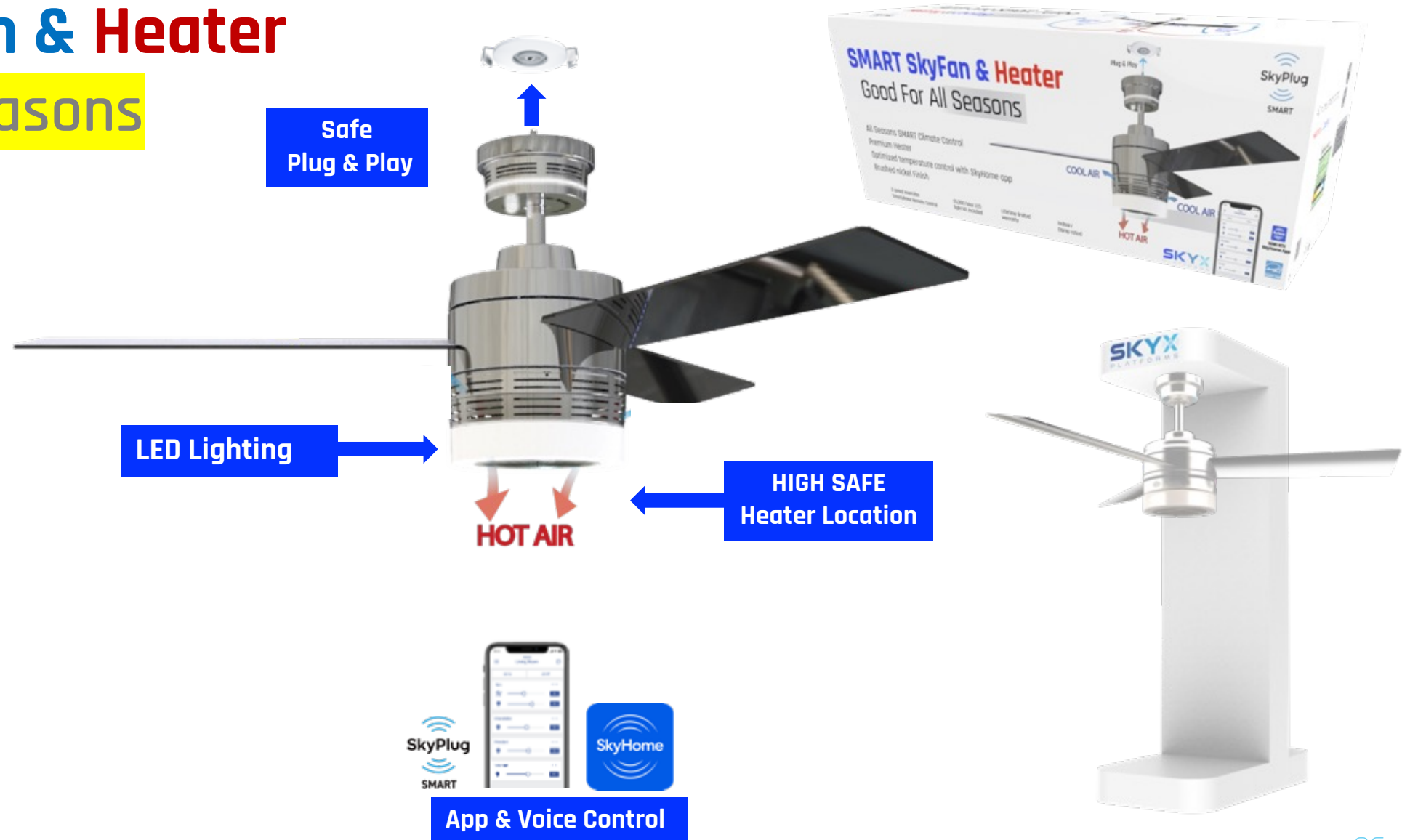

SKYX's Plug & Play Products

1-Pack SkyOutlet



4-Pack SkyOutlet



Plug & Play SMART Lighting Base



SMART & Plug & Play Recessed Light



All-In-One SMART Platform



8-Pack SkyOutlet



Plug & Play Lighting Base



24-Pack SkyOutlet



All-In-One SMART HEATER & FAN

LEAD & SEED

GEN 1-2-3
SMART LIGHTING
& FANS

SAFE - SMART
plug & play
FANS

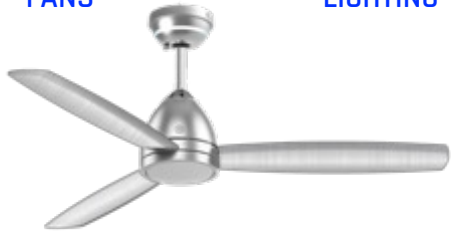

SAFE- SMART
plug & play
LIGHTING

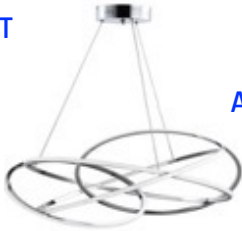

SAFE- SMART
plug & play
All-In-One Smart
Platform



Channels

- Online
- Retail
- Builders
- Hotels

Product Advantages

- Simplifying
- Saving 70% to 99% Of Installation Time
- Saving 50% to 90% Of Installation Cost
- Enhancing replacement and adoption of new lighting , fan and smart products
- All-In-One Solution

SEED PRODUCTS

GEN 1-2-3
STANDARD &
SMART PLUGS
SMART PLATFORM

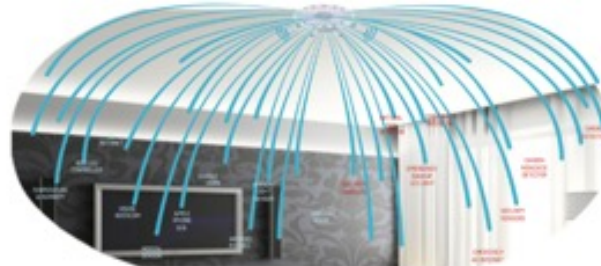

- Licensing
- OEM
- Online
- Retail
- Builders
- APT Rentals
- Hotels/Cruises
- Online/Retail
- Commercial
- Subscriptions

Our Products: Save **Lives** – Save **Cost** – Save **Time** – **Advance** And **Simplify**

1

PR Campaign



2

Launch Online Sales



3

Retail, Wholesale & OEM

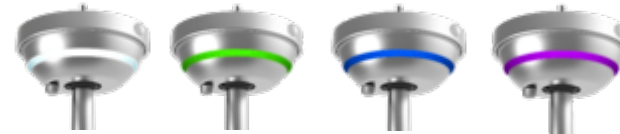

4

Builders, Apt Buildings, Hotels



5

Licensing & Selling Country Rights Globally



SKYX - GE GLOBAL Licensing Opportunity



Licensing our 97 Patents and Pendent Applications to:

Lighting Industry - Electrical Industry - Tech/Smart Home Industry

Light Plug & Receptacle



Downlight/Recessed plug & Receptacle

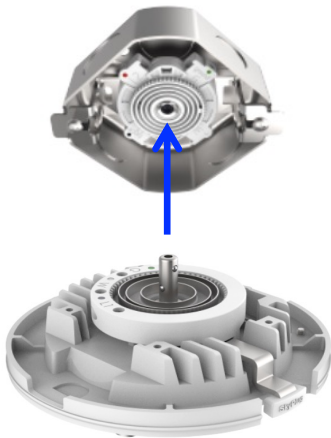

Smart Light Plug



Fan Plug / Bracket & Receptacle

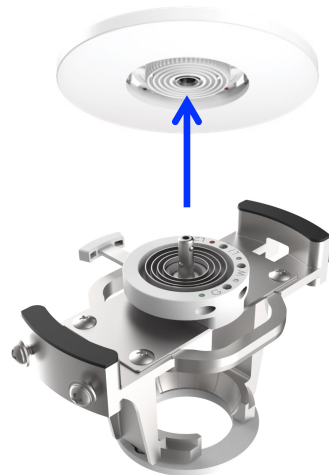

Smart FAN Plug



All-In-One Smart Home platform





Building Safety Codes SkyPlug & Ceiling Outlet / Receptacle

Most Significant Addition to the NEC Code in 40 Years

WALL OUTLET/RECEPTACLE



NEC SAFETY CODE

Wall

Outlet / Receptacle

1900's

WALL Outlet - GFCI

GFCI
(Ground Fault
Circuit Interrupter)



NEC SAFETY CODE

Wet Location Wall

Outlet / Receptacle

1980's

WSCR SKYX's NEW NEC CEILING OUTLET / RECEPTACLE

WSCR
(Weight Support
Ceiling Receptacle)



NEW NEC SAFETY CODE

NEC Voted WSCR as
a Generic Name for SKYX's
Ceiling Outlet Receptacle

2024

HISTORIC ADDITIONS To The U.S. Safety Building Codes

- Voted into 10 NEC segments segments in the U.S. Electrical Building code in the past 12 years
- Historical Approval Vote by ANSI / NEMA, US Home & Building Standardization Organizations
(ANSI: American National Standardization Institute)
(NEMA: National Electrical Manufactures Association)
- SKYX is part of the American Institute of Architects (AIA) Safety Continuing Education Program
- After 120 years, changing the definition of the receptacle in the NEC Code Book to include the SKYX's Ceiling Outlet/Receptacle.

Lighting - Electrical Related Fires - Annual

National Fire Protection Association (NFPA) Data for Lighting & Electrical Distribution Equipment FIRES – 2015 to 2019 annual averages associated with lighting products:

- **430 civilian deaths per year**
- **Not including electrocutions**
- **Not including ladder falls**

Home Fires Caused by Electrical Distribution and Lighting Equipment, NFPA Feb 2022:
<https://www.nfpa.org/News-and-Research/Data-research-and-tools/Electrical>

OUR PRODUCTS:

- **SAVES LIVES**
- **REDUCES ELECTROCUTIONS, LADDER FALLS, FIRES**
- **PREVENTS HAZARDOUS INCIDENTS**
- **ENHANCES ALL AROUND HOME SAFETY**

OUR PRODUCTS PROVIDE: Smoke Detectors - Carbon Monoxide Detectors, Emergency Light, Emergency 4G Internet, Emergency Intercom - Emergency Siren, Security Sensors, Security Cameras and more...

Organizational Chart

Board of Directors

Dov Shiff
Director
 Gov. Tom Ridge
Lead Director
 Leonard Sokolow JD,
Director CO-CEO
 Efrat Greenstein Brayer
Director
 Nancy DiMattia
Director
 Gary Goldman
Director

Senior Advisors

Bob Nardelli
Code Team Leader and Senior Advisor
 Al Weiss
Senior Business Advisor
 Khadija Mustafa
Senior Tech Advisor

Executives

Steve Schmidt
President
 Rani Kohen
Founder Executive Chairman
 Leonard Sokolow
CO-CEO
 John Campi
CO-CEO

Code Team

Mark Earley
Code Team Leader
 Eric Jacobson
Code Team Leader
 Patty Barron
COO & Code Team
 Chuck Mello
Code Team Team
 Amy Cronin
Code Team Engineer

 David Usha
Head Of China Offices
 Michael Perillo
Global Sales
 Steve Briggs
Business Development
 Mark Wells
President lighting
 Dave Pamer
President Retail/Wholesale
 Eliran Ben Zikri
CTO
 Marc-Andre Boisseau
CFO
 Rob Powell
General Counsel
 Jonathan Globerson
Product Development
 Shane Robinett
Data/Subscriptions strategy
 John Pool
Retail Sales
 Ashley Baron
Social Media

China Offices

Phoebe Chung
Admin.& Accounting
 Keller Wn.
Fan & Lights Engineer Production rMg
 Rex Chung
Fan Engineer Production Mgr
 Rayman Liu
Mechanical Engineering
 Annie He
QC,QA controller
 Christina Peng
Lighting Product Merchandiser
 Ken Ng
Head of Factoriles Audit Head of QCAccount Controller
 Wan Leung
Admin
 Yick Wang
QC
 James Zhou
QC
 Leo Kuang
QC

Tech Development Team

Ofer Zvik
Engineering
 Rafi Cohen
Supply Chain
 Ben Skittel
Operations
 Chen Shapira
Infrastructure Lead
 Izhak Alylahu
Board Designer
 Shahaar Sery
Board Designer
 Tal Ofer
Verification
 Alexander Kilansky
Software Engineer
 Sara Packter
Embedded Engineer
 Gradimir Ljubibratic
Embedded Engineer
 Marcin Barowicz
Embedded Engineer
 Sallish Kasaju
Mobile Lead
 Newana Tandukar
Software Engineer
 Pradip Shrestha
Software Engineer
 Ilan Groidy
Embedded Engineer
 Avi Shaya
Layout Engineer

Product Development

Derek Mir
Industrial Designer
 Adrian Baragan
Animator
 Diego Beristain
Brand Designer

Sales and Customer Support

Amy McGriff
Marketing
 Veronica Terrell
Marketing
 Sirod Carpenter
Customer Service

Advisors

Israel Kaminsky
Senior Engineer
 Murray Lee
QC Leader

Experienced Management Team



Rani Kohen
Founder & Executive Chairman

Renowned businessman, entrepreneur and the founder of Sky Technologies – currently serving as the Executive Chairman of the board, a role Mr. Kohen has held since 2016. He brings strategic acumen with over 20 years of experience in business, as well as in advanced safety and smart home technologies, product design, lighting, and other related businesses. Since founding the Company, he has succeeded in attracting and engaging accomplished board members, talented management and leading executives from various industries.



Steve Schmidt
President

Joined the Company in 2020. Mr. Schmidt was the former President & CEO of AC-Nielson Corporation and was also the former President of Office Depot International. During that time, He was in-charge of 6,000 stores in more than 50 countries. Previously, he was President of Canada and Southeast Asia for Pillsbury Food Company. Previously, Steve held management positions at PepsiCo and Procter & Gamble as well.



Leonard J. Sokolow
CO-CEO and a member of the Company's Board

Serving as CO-CEO since 2023. Serves on SKYX Board of Directors since 2015. Mr. Sokolow also serves on Board of directors of Consolidated Water Co (Nasdaq: CWCO), Vivos Therapeutics (Nasdaq: VVOS), Agrify Corporation (Nasdaq: AGFY), Marquee Energy. (formerly Alberta Oilsands Inc.) (then TSXV: MQX) Former CEO and President of Newbridge Financial, Inc. and Chairman of its broker dealer subsidiary, Newbridge Securities Served in a variety of roles at vFinance, Inc., a publicly traded financial services company, including Chairman and CEO



John Campi
CO-CEO

Serving as CEO since 2014. Mr. Campi was the former Chief Procurement Officer and an Executive Vice President for Chrysler, SVP for Global Sourcing at Home Depot, GM for GE Power Systems and Executive Vice President for DuPont. Mr. Campi has extensive experience in the field of cost management, is recognized as a founder of the strategic cost-management discipline known as Activity-Based Cost Management and has extensive experience in the field of supply chain management.



Marc-Andre Boisseau
Chief Financial Officer

Mr. Boisseau served as the former Chief Accounting officer at Citrix Systems, Inc., a publicly-traded software development company, as Principal Accounting Officer, and as a senior auditor at Ernst & Young. Mr. Boisseau is a certified public accountant. Additionally, he is a partner of Boisseau, Felicione & Associates Inc., which provides assurance, advisory and tax services for public and private companies in a variety of industries.



Patricia Barron
Chief Operations Officer

COO Of the Company. Prior to joining the Company, Ms. Barron was the President and owner of LTG Services, Inc., a company focused on safety consulting services, specializing in the review and compliance of electrical products. Prior to that, Ms. Barron worked as a consultant and engineer in the lighting, safety and approval industry as well as an engineering assistant for Underwriters Laboratories, Inc. (n/k/a UL) in the ceiling fan category. Ms. Barron received her MBA from Georgia State University.



Eliran Ben-Zikri
Chief Technology Officer

Joined the Company in 2019 CTO and GM of Sky's Israeli Office. He served in one of the most elite computer units of the Israeli Defense Force and has over 10 years of experience in the technology and cloud technology industry, previously holding senior positions in leading Israeli tech companies, including eToro and SimilarWeb. He has a vast experience in the Internet of Things, data collection, data processing, analytics, security, cloud, and production.



NASDAQ: SKYX



www.skyplug.com