

COMPENSATED HYDRAULIC BLOCK - BANKABLE VERSION for MODUL-GATE

The main valve is designed for the installation of a compensated hydraulic block. This hydraulic block provides the pressure compensation, keeping the same speed even with the load pressure variation on each movement. The auxiliary elements with direct electric control with or without lever, are bankable up to a maximum of 8 sections.

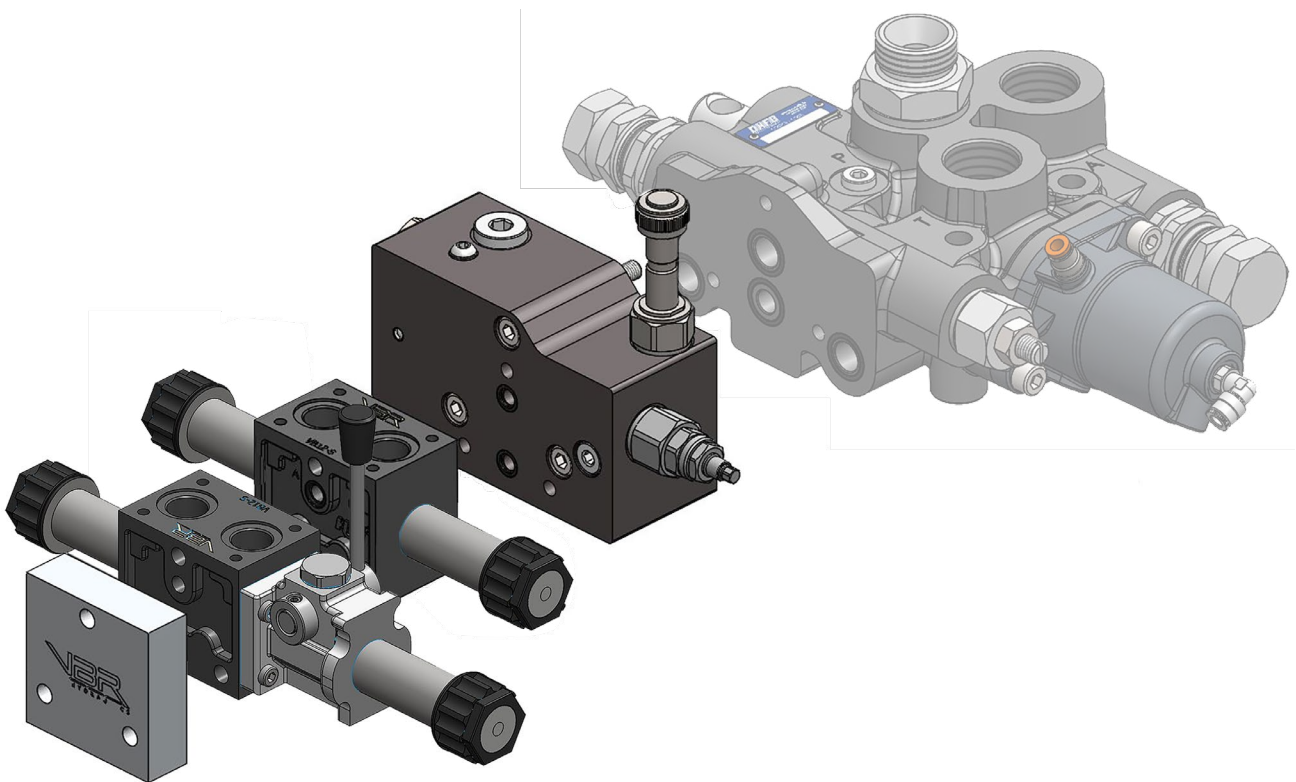

For all order codes, technical specifications and accessories (connectors, solenoid valves, locking rod kits, etc.), see the relevant data sheet by clicking on the link.



Our sales department is available for any further information.