

EPA-450/2-77-036
December 1977
(OAQPS No. 1.2-089)

GUIDELINE SERIES

**CONTROL OF VOLATILE
ORGANIC EMISSIONS
FROM STORAGE
OF PETROLEUM LIQUIDS
IN FIXED-ROOF TANKS**

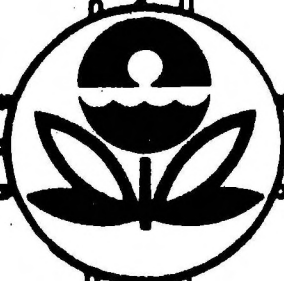

U.S. ENVIRONMENTAL PROTECTION AGENCY
Office of Air and Waste Management
Office of Air Quality Planning and Standards
Research Triangle Park, North Carolina 27711

**EPA-150/2-77-036
(OAQPS No. 1.2-089)**

**CONTROL OF VOLATILE
ORGANIC EMISSIONS
FROM STORAGE OF PETROLEUM
LIQUIDS IN FIXED-ROOF TANKS**

by

Emissions Standards and Engineering Division
Chemical and Petroleum Branch

U.S. ENVIRONMENTAL PROTECTION AGENCY
Office of Air and Waste Management
Office of Air Quality Planning and Standards
Research Triangle Park, North Carolina 27711

December 1977

OAQPS GUIDELINE SERIES

The guideline series of reports is being issued by the Office of Air Quality Planning and Standards (OAQPS) to provide information to state and local air pollution control agencies; for example, to provide guidance on the acquisition and processing of air quality data and on the planning and analysis requisite for the maintenance of air quality. Reports published in this series will be available - as supplies permit - from the Library Services Office (MD-35), U.S. Environmental Protection Agency, Research Triangle Park, North Carolina 27711; or, for a nominal fee, from the National Technical Information Service, 5285 Port Royal Road, Springfield, Virginia 22161.

Publication No. EPA-450/2-77-036

(OAQPS No. 1.2-089)

TABLE OF CONTENTS

	<u>Page</u>
Chapter 1.0 Introduction	1-1
1.1 Need to Regulate	1-1
1.2 Regulatory Approach	1-4
1.3 References	1-5
Chapter 2.0 Sources and Types of Emissions	2-1
2.1 Fixed Roof Tanks	2-1
2.2 Emissions	2-3
2.3 References	2-5
Chapter 3.0 Control Technology	3-1
3.1 Internal Floating Roof Tank	3-1
3.2 Control Effectiveness	3-4
3.3 References	3-4
Chapter 4.0 Cost Analysis	4-1
4.1 Introduction	4-1
4.1.1 Purpose	4-1
4.1.2 Scope	4-1
4.1.3 Use of Model Storage Tanks	4-1
4.1.4 Bases for Capital and Annualized Cost Estimates	4-3
4.2 Control of Emissions from Fixed Roof Storage Tanks	4-4

	<u>Page</u>
4.2.1 Model Cost Parameters	4-4
4.2.2 Control Costs	4-4
4.3 Cost Effectiveness	4-7
4.4 References	4-14
Chapter 5.0 Effects of Applying the Technology	5-1
5.1 Air Pollution Impacts	5-1
5.2 Other Effects	5-1
5.3 Reference	5-1
Chapter 6.0 Recommended Regulations, Compliance Test Method, and Record Keeping	6-1
6.1 Recommended Regulations	6-1
6.2 Compliance Test Method	6-2
6.3 Monitoring and Record Keeping	6-2

LIST OF TABLES

	<u>Page</u>
Table 2-1 Tank Inventory and Emissions	2-4
Table 4-1 Technical Parameters Used in Developing Control Costs	4-2
Table 4-2 Cost Parameters Used in Computing Control Costs	4-5
Table 4-3 Control Cost Estimates for Model Existing Fixed Roof Tanks	4-6
Table 4-4 Cost Effectiveness of Controlling Small Fixed Roof Tank	4-8
Table 4-5 Cost Effectiveness of Controlling Medium Size Fixed Roof Tank	4-9
Table 4-6 Cost Effectiveness of Controlling Large Fixed Roof Tank	4-10

LIST OF FIGURES

	<u>Page</u>
Figure 2-1 Typical Fixed Roof Tank	2-2
Figure 3-1 Schematic of Typical Fixed Roof Tank With Internal Floating Cover	3-2
Figure 3-2 Typical Flotation Devices and Perimeter Seals for Internal Floating Covers and Covered Floating Roofs	3-3
Figure 4-1 Cost Effectiveness of Controlling Emissions from Existing Fixed Roof Gasoline Tanks	4-12
Figure 4-2 Cost Effectiveness of Controlling Emissions from Existing Fixed Roof Crude Oil Tanks	4-13

ABBREVIATIONS AND CONVERSION FACTORS

EPA policy is to express all measurements in agency documents in metric units. Listed below are abbreviations and conversion factors for British equivalents of metric units.

<u>Abbreviations</u>	<u>Conversion Factor</u>
l - liters	atm X 101,325 = Pascals psia X 6,893 = Pascals liters X .26 = gallons gallon X 3.79 = liters $\frac{\text{kg}}{\text{yr}} \times 1.1 \times 10^{-3} = \frac{\text{tons}}{\text{yr}}$
kg - kilograms	kilograms X 2.203 = pounds
Mg - megagram	pounds X .454 = kilograms
m tons - metric tons	10^6 gms = 10^3 kg tons X .907 = metric tons
m - meters	meters X 3.28 = feet
cm - centimeters	centimeters = inches X 2.54
$\text{kg}/10^3$ l - kilograms/thousand liters	$\text{kg}/10^3$ liters X 8.33 = $\text{lb}/10^3$ gal $\text{lg}/10^3$ gal X .12 = $\text{kg}/10^3$ l
Pa - Pascals	1 kPa = 1000 Pa
kPa - kilo Pascals	gallons X 42 = barrels

Frequently used measurements in this document are:

150,000 l ~ 40,000 gallons	10.5 kPa ~ 1.52 psia
$1,590 \times 10^3$ l ~ 10,000 barrels	560,000 Mg/yr ~ 617,300 tons/yr
$8,750 \times 10^3$ l ~ 55,000 barrels	134,000 Mg/yr ~ 147,700 tons/yr
$23,850 \times 10^3$ l ~ 150,000 barrels	56,000 Mg/yr ~ 61,700 tons/yr
13.8 kPa ~ 2.0 psia	
41.4 kPa ~ 6.0 psia	
69.0 kPa ~ 10.0 psia	

Definition of Terms

- A. Condensate means hydrocarbon liquid separated from natural gas which condenses due to changes in the temperature and/or pressure and remains liquid at standard conditions.
- B. Crude oil means a naturally occurring mixture which consists of hydrocarbons and/or sulfur, nitrogen and/or oxygen derivatives of hydrocarbons and which is a liquid at standard conditions.
- C. Custody transfer means the transfer of produced crude oil and/or condensate, after processing and/or treating in the producing operations, from storage tanks or automatic transfer facilities to pipelines or any other forms of transportation.
- D. External floating roof means a storage vessel cover in an open top tank consisting of a double deck or pontoon single deck which rests upon and is supported by the petroleum liquid being contained and is equipped with a closure seal or seals to close the space between the roof edge and tank shell.
- E. Internal floating roof means a cover or roof in a fixed roof tank which rests upon or is floated upon the petroleum liquid being contained, and is equipped with a closure seal or seals to close the space between the roof edge and tank shell.
- F. Petroleum liquids means crude oil, condensate, and any finished or intermediate products manufactured or extracted in a petroleum refinery.
- G. Petroleum refinery means any facility engaged in producing gasoline, kerosene, distillate fuel oils, residual fuel oils, lubricants, or other products through distillation of crude oil, or through redistillation, cracking, extraction, or reforming of unfinished petroleum derivatives.

H. True vapor pressure means the equilibrium partial pressure exerted by a petroleum liquid as determined in accordance with methods described in American Petroleum Institute Bulletin 2517, Evaporation Loss from Floating Roof Tanks, 1962.

in areas of the country where National Ambient Air Quality Standards (NAAQS) are not being attained. Storage tanks for petroleum liquids are a significant source of VOC.

EPA promulgated a New Source Performance Standard (NSPS) for storage of petroleum liquids on March 8, 1974. One provision of the standard requires that new or modified tanks of capacity greater than 151,412 liters storing liquids whose true vapor pressure is 10.5 to 76.5 kilo Pascals be controlled by a floating roof (external or internal) or equivalent.

Preliminary results from an on-going study indicate that combined emissions from fixed roof and external and internal floating roof storage tanks are about 830,000 Mg per year.¹ Of these emissions it is estimated that 560,000 Mg per year are from fixed roof storage tanks containing petroleum liquids with true vapor pressures above 10.5 kPa. The magnitude of these emissions indicates the need for broader application of the NSPS requirements to existing tanks.

Existing fixed roof tanks with greater than 150,000 liter capacity containing petroleum liquids with true vapor pressure greater than 10.5 kilo-Pascals should be controlled by retrofitting with internal floating roofs or equivalent external floating roofs, vapor recovery, vapor disposal systems, or other equivalent control technology. Bolted tanks generally cannot be retrofitted with internal floating roofs, and thus will require alternative equivalent control technology.

The affected facility is the fixed roof storage tank. The recommendations do not apply to storage tanks equipped with external floating roofs or to storage tanks having capacities less than 1,600,000 liters used to store crude oil and condensate prior to lease custody transfer.

Field studies that have been conducted by Western Oil and Gas Association² and pilot studies conducted by the Chicago Bridge and Iron Company^{3,4,5,6} are

being reviewed to assess the need for more specific regulations dealing with external floating roofs. It is expected that the analysis will be completed in 1978.

A study has been initiated to determine emissions from onshore oil and gas drilling and production. Quantification of emissions from the storage of produced crude oil and condensate is included. This study is scheduled for completion in July, 1978. A decision regarding the need to prepare a guideline document specific to production tanks will be made at that time.

Cost effectiveness of controlling emissions from fixed roof tanks by retrofitting with internal floating covers is dependent on tank size, product type, product value, number of annual tank turnovers, and other factors. For example, the median cost for retrofitting a small $1,590 \times 10^3$ liter fixed roof tank with an internal cover is \$15,000. The cost to retrofit a large $23,850 \times 10^3$ liter tank is \$57,000. Annualized control costs are \$3,000 and \$11,700, respectively. These costs remain the same regardless of the product stored. However, cost effectiveness for the small tank can range from a cost of \$240 per Mg of VOC controlled when storing crude oil at low vapor pressure and low annual turnover, to a credit of \$115 per Mg when storing gasoline at a higher vapor pressure and a higher annual turnover rate. Similarly, the large tank has a cost effectiveness ranging from a cost of \$35 per Mg for crude oil and a credit of \$140 per Mg when storing gasoline.

For some areas it may be reasonable to apply the control strategy to all fixed roof tanks with a capacity greater than 150,000 liters storing products with a true vapor pressure greater than 10.5 kilo Pascals. Nevertheless, the economic impact on small refiners and small tank operators should be considered.

Also not included in the cost effectiveness analysis is the cost of the value of storage capacity lost during retrofit and the hardship that may be created for the operator who may have only one tank available for storage of a particular product.

1.2 REGULATORY APPROACH

Mass emission rates for storage tanks are extremely difficult to quantify because of the varying loss mechanisms and the number of variables affecting loss rate. As a result it is not possible to develop enforceable performance standards. Regulations should therefore be written in terms of equipment specifications and maintenance requirements rather than mass emission rates. Regular inspections will be required to ensure proper use and maintenance of control equipment.

1.3 REFERENCES

1. Evaluation of Hydrocarbon Emissions From Petroleum Liquid Storage, Pacific Environmental Services, Inc., Santa Monica, California, EPA-450/3-78-012, March, 1978.
2. Hydrocarbon Emissions From Floating Roof Petroleum Tanks, Engineering-Sciences Inc., Arcadia, California, for Western Oil and Gas Association, January, 1977.
3. SOHIO/CBI Floating Roof Emissions Program, Interim Report, October 7, 1976.
SOHIO/CBI Floating Roof Emissions Program, Final Report, November, 1976.
4. Western Oil and Gas Association, Metallic Sealing Ring Emission Test Program, Interim Report, Chicago Bridge and Iron Company, January, 1977.
5. Western Oil and Gas Association, Metallic Sealing Ring Emission Test Program, Final Report, Chicago Bridge and Iron Company, March, 1977.
6. Western Oil and Gas Association, Metallic Sealing Ring Emission Test Program, Supplemental Report, Chicago Bridge and Iron Company, June, 1977.

2.0 SOURCES AND TYPES OF EMISSIONS

There are an estimated 26,000 fixed roof storage tanks holding petroleum liquids at refineries, terminals, tank farms, and along pipelines.¹ It is estimated that 7,300 of those are storing liquids with true vapor pressures exceeding 10.5 kPa.² These tanks are generally loaded by submerged (bottom) fill. They are unloaded into tank cars, tank trucks, ships, barges, or pipelines.

2.1 FIXED ROOF TANKS

Fixed roof tanks consist of a steel cylindrical shell with a permanently affixed roof (see Figure 2.1). The roof design may vary from cone-shaped to flat.

Of presently employed tank designs, the fixed roof tank is the least expensive to construct and is generally considered as the minimum accepted standard for storage of petroleum liquids. The tank is designed to operate at only slight internal pressure or vacuum and as a result the emissions from breathing, filling, and emptying can be appreciable.

Breathing loss is the expulsion of vapor from the tank due to expansion and contraction resulting from diurnal temperature and barometric pressure changes. They occur in the absence of any liquid level change in the tank. Filling losses are associated with an increase of the liquid level in the tank. Emptying losses occur when air drawn into the tank becomes saturated

Figure 2-1 TYPICAL FIXED ROOF TANK

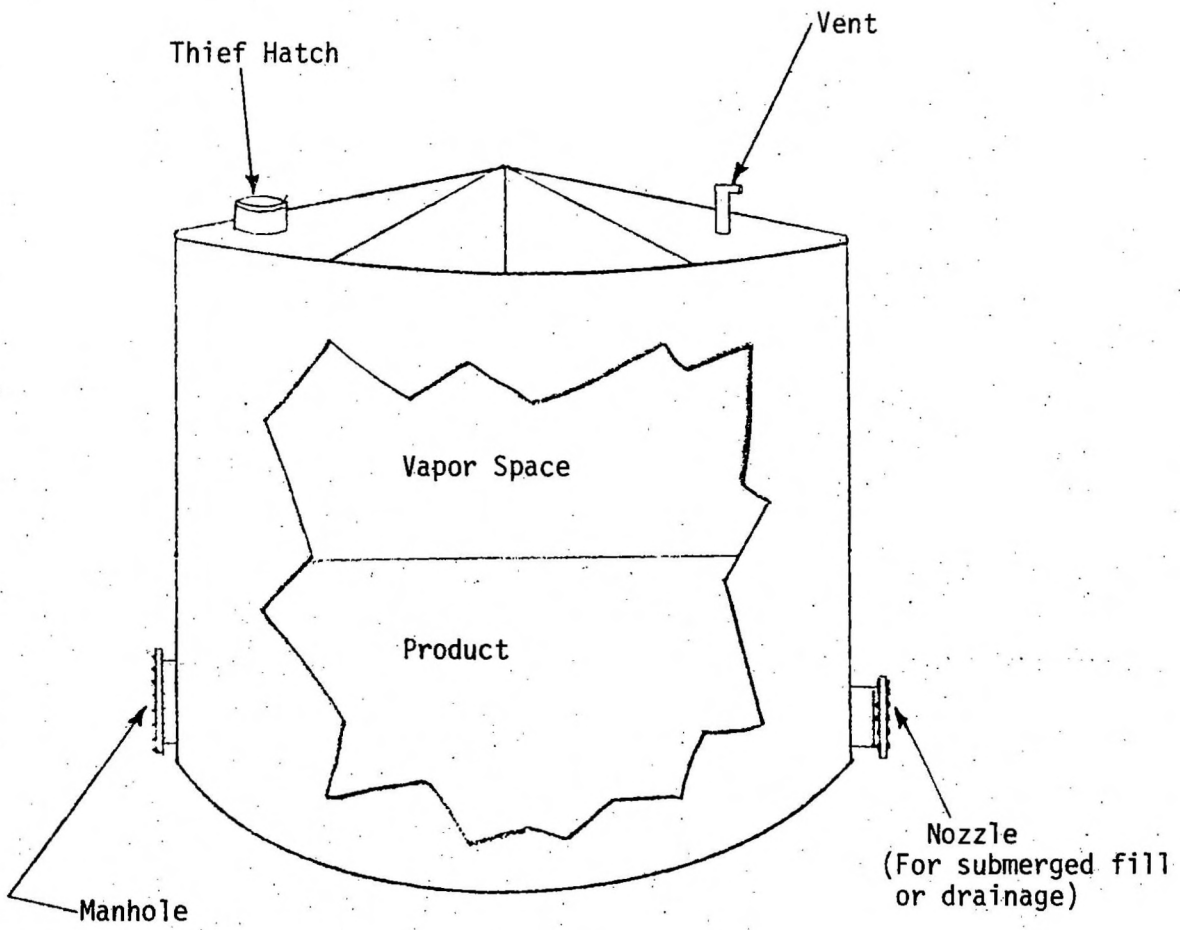

with hydrocarbon vapor and expands such that it exceeds the capacity of the vapor space. Combined filling and emptying losses are called "working losses."

Breather valves (pressure-vacuum) are commonly installed on many fixed roof tanks to prevent vapors from escaping due to small temperature and barometric pressure changes or very small liquid level fluctuations. However, these valves will vent vapors to the air during normal filling and will draw air into the tank during emptying.

2.2 EMISSIONS

For petroleum liquids having true vapor pressures above 10.5 kPa, it is estimated that fixed roof tanks emit about 560,000 Mg per year of VOC.^{3,5} External floating and internal floating roof tanks emit about 134,000 Mg per year from liquids having true vapor pressures above 10.5 kPa (see Table 2-1).

For this volatility range, fixed roof tanks comprise forty percent of the total tank population (over 150,000 l. capacity), or about 7300 tanks.⁴ Fixed roof tanks emit eighty percent of the total storage losses from the same volatility and size range.

Table 2-1. TANK INVENTORY AND EMISSIONS^{1,2}

Vapor Pressure Range kilo Pascals	Fixed Roof		Floating & Internal Floating Roof		TOTAL	
	Tanks	Emissions 10 ³ Mg/yr	Tanks	Emissions 10 ³ Mg/yr	Tanks	Emissions 10 ³ Mg/yr
10.5 to 35.5	5,840	406	7,093	64	12,933	470
35.5 to 62.7	1,396	135	3,357	61	4,753	196
62.7 to 76.5	49	16	218	9	267	25
TOTAL	7,285	557	10,668	134	17,953	691

1 Includes only tanks with greater than 150,000 l capacity

2 Calculated from AP-42, Supplement 7, April, 1977

2.3 REFERENCES

1. Evaluation of Hydrocarbon Emissions From Petroleum Liquid Storage, Pacific Environmental Services, Inc., Santa Monica, California, EPA-450/3-78-012, March, 1978.
2. Ibid.
3. Ibid.
4. Ibid.
5. Compilation of Air Pollutant Emission Factors, Supplement 7, U. S. Environmental Protection Agency, April, 1977.

3.0 CONTROL TECHNOLOGY

Fixed roof tank emissions are most readily controlled by the installation of internal floating roofs. This chapter will discuss internal floating roof tanks.

3.1 INTERNAL FLOATING ROOF TANKS

An internal floating roof tank is essentially a fixed roof tank with a cover floating on the liquid surface inside the tank, rising and falling with the liquid level (See Figure 3.1). There are two types of internal covers: (1) a pan type steel floating roof or (2) a non-ferrous floating cover. An internal floating roof tank having a steel pan floating roof is defined as a covered floating roof. If the floating roof is non-ferrous, as aluminum or polyurethane, it is defined as an internal floating cover. The fixed roof protects the floating roof and seal from deterioration due to climatological effects and eliminates the possibility of the roof sinking because of rain or snow loads.

Whatever the floating roof design, a closure device must be used to seal the gap between the tank shell and the floating roof around the roof perimeter. Special materials are available for the closure device in a wide range of designs to accommodate the entire spectrum of petroleum liquids. Figure 3.2 illustrates several typical flotation devices and perimeter closure seals for internal floating covers and covered floating roofs.

Other modifications may also be necessary in a fixed roof tank before equipping it as an internal floating roof tank. Tank shell deformations and obstructions may require correction, special structural

FIGURE 3-1

SCHMATIC OF TYPICAL FIXED ROOF TANK WITH INTERNAL FLOATING COVER

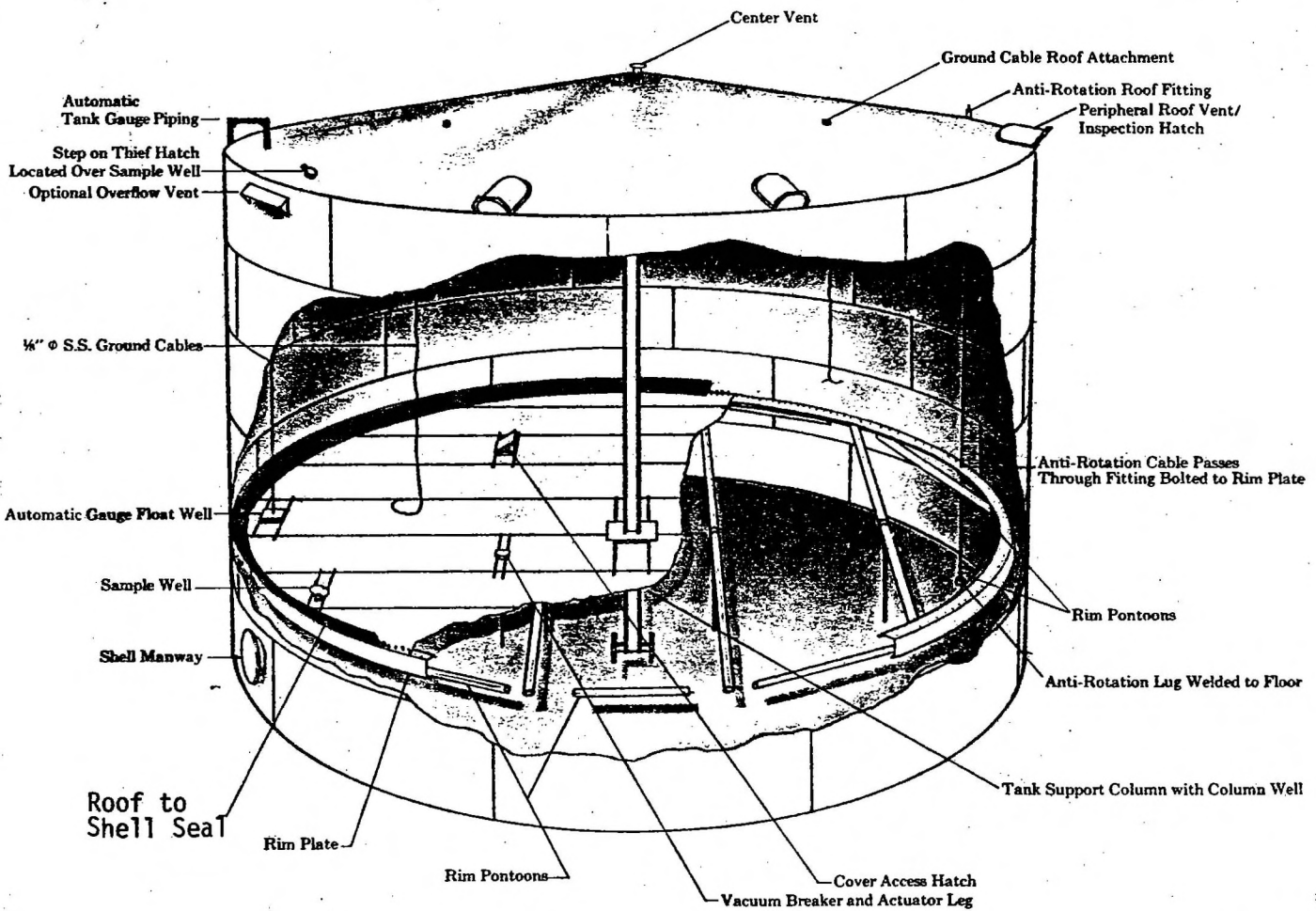

Figure 3-2

Typical Flotation Devices and Perimeter Seals for Internal Floating Covers, and Covered Floating Roof¹

(A)

INTERNAL FLOATING COVERS

(A-1)

Aluminum deck supported above liquid by tubular aluminum pontoons

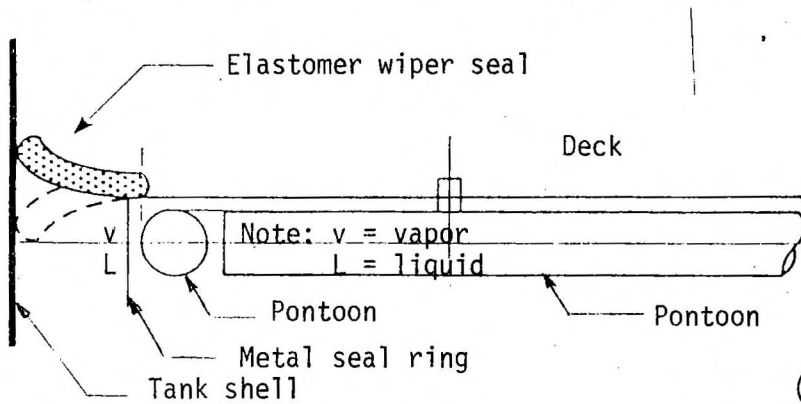

(A-2)

Aluminum panel deck supported above liquid by aluminum floats with polyurethane foam

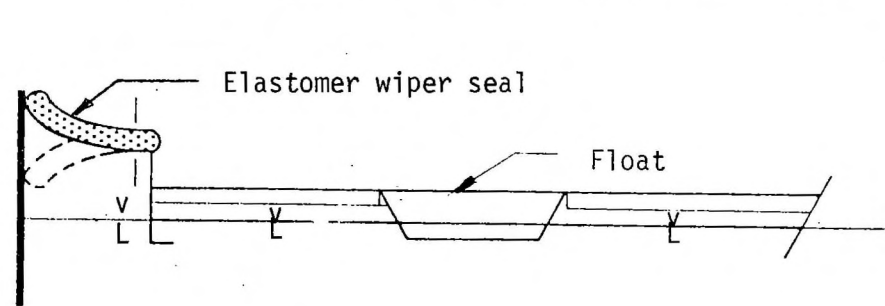

(A-3)

Aluminum sandwich panels with honeycombed aluminum core floating on surface

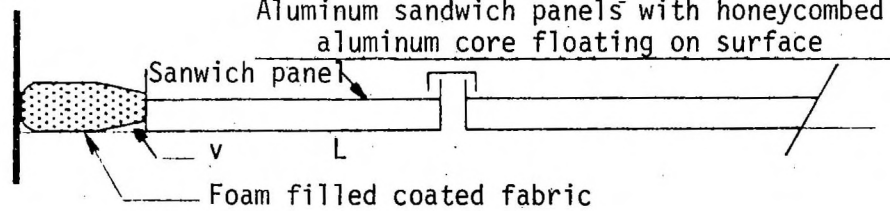

(B)

COVERED FLOATING ROOF

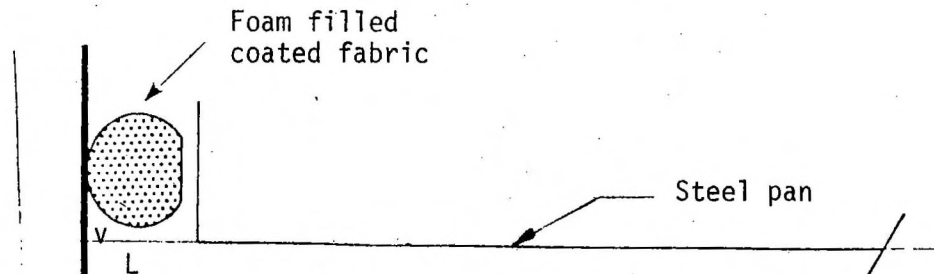

Based on Annex A, API Publication 2519, Second Edition

modifications such as bracing, reinforcing, and plumbing vertical columns may be necessary. Anti-rotational guides should be installed to keep cover openings in alignment with roof openings. Special vents are installed on the fixed roof or on the walls at the top of the shell to minimize the possibility of VOC's approaching the flammable range in the vapor space.

3.2 CONTROL EFFECTIVENESS

Calculations indicate that emission reductions of more than 90 percent are achieved by retrofitting fixed roof tanks with internal floating roofs.¹

3.3 REFERENCE

1. Compilation of Air Pollutant Emission Factors, Supplement 7, U. S. Environmental Protection Agency, April, 1977.

4.0 COST ANALYSIS

4.1 INTRODUCTION

4.1.1 Purpose

The purpose of this chapter is to present estimated costs for control of volatile organic compound (VOC) emissions from existing fixed roof petroleum liquids storage tanks.

4.1.2 Scope

Estimates of capital and annualized costs are presented for controlling emissions from existing welded steel fixed roof tanks used for storing petroleum liquids. The cost of control consists of modifying existing tanks by retrofitting internal floating roofs equipped with closure seals.

Control costs and cost effectiveness ratios are developed for three model sizes - a small tank with a 15.2 m diameter, a 9.2 m height and a 1590×10^3 l capacity; a medium size tank with a 30.5 m diameter, a 12.2 m height and a 8750×10^3 l capacity; and a large tank with a 45.7 m diameter, a 14.6 m height and a $23,850 \times 10^3$ l capacity. A range of cost effectiveness ratios are presented for each model size tank for storing gasoline and crude oil that allow for varying operating conditions and locations of tanks.

4.1.3 Use of Model Storage Tanks

Table 4-1 presents the technical parameters for the three model sizes of fixed roof petroleum liquids storage tanks. From an inventory of fixed roof tanks taken by an EPA contractor,⁶ the 1590×10^3 l tank was selected as representative of small tanks, the 8750×10^3 l tank was selected as representative of medium sized tanks, and the $23,850 \times 10^3$ l tank was selected as representative of large tanks. Emissions before and after control were calculated.¹

Emissions from Gasoline: 671 Kg/m³

Emissions from Crude Oil: 539 Kg/m³

III. Emissions Before Control (Mg/yr):^b

A. Emissions From Gasoline Storage

No. of Turnovers/Year	Small Tank			Medium Tank			Large Tank		
	5	10	20	5	10	20	5	10	20
<u>True Vapor Pressure kPa</u>									
13.8	12.0	15.0	21.0	52	68	101	123	168	258
27.6	22.0	28.0	40.0	96	129	195	229	359	499
41.4	34.0	43.0	61.0	145	194	293	346	481	751
55.2	48.0	60.0	84.0	204	325	402	486	666	1026
69.0	68.0	83.0	113.0	288	370	535	498	903	1353

B. Emissions From Crude Oil Storage (Mg/yr)^b

No. of Turnovers/Year	Small Tank			Medium Tank			Large Tank		
	5	10	20	5	10	20	5	10	20
<u>True Vapor Pressure kPa</u>									
13.8	6.9	8.8	12.6	28.5	38.9	59.9	67.5	96	153
27.6	11.8	15.6	23.2	51.9	72.8	114.6	126	183	297
41.4	17.7	23.4	34.8	78.4	109.7	172.4	191	276	447
55.2	25.6	33.2	48.4	110.8	152.6	236.2	267	381	609
69.0	36.5	46.0	65.0	154.3	206.5	311.0	369	511	796

IV. Emissions After Control (Mg/yr):^b

True Vapor Pressure (kPa)	Small Tank		Medium Tank		Large Tank	
	Gasoline	Crude Oil	Gasoline	Crude Oil	Gasoline	Crude Oil
13.8	1.0	0.7	2.9	1.9	5.3	3.4
27.6	1.9	1.2	5.3	3.4	10.0	6.3
41.4	2.9	1.9	8.2	5.3	15.0	9.7
55.2	4.2	2.7	12.0	7.8	22.0	14.2
69.0	6.4	4.1	18.0	11.6	33.0	21.3

^a Estimated density of condensed vapor emitted from storage tanks.

^b Reference 1; emissions, calculated per AP-42, Supplement No. 7.

Emissions from petroleum liquids vary with true vapor pressure, throughput, and type of product stored. Gasoline and crude oil have different economic values and emission rates. In order to allow for typical varying operating conditions and locations of storage tanks, a range of petroleum credits are determined using estimated low, median, and high values of the above variables. Since control costs vary with the size and location of tanks, a range of cost effectiveness ratios are developed for each of the three model sizes using estimated low, median, and high control costs. However, actual control costs may differ from the estimated costs because of the condition and configuration of the tank(s).

4.1.4 Bases for Capital and Annualized Cost Estimates

Capital cost estimates represent the investment required to purchase and retrofit the control systems on existing fixed roof storage tanks. Costs for research and development, cleaning and degassing tanks, correction of tank defects, loss of use of tanks during retrofit, and other highly variable costs are not included in the estimates. All capital costs reflect second quarter 1977 dollars.

Annualized control cost estimates include operating labor, maintenance, inspections, credits for petroleum savings, and annualized capital charges. Cost estimates were obtained from an EPA contractor, equipment vendors, an oil and gas association and an API contractor. Credits for petroleum savings due to emission control (reduction) have been calculated.¹

The annualized capital charges are sub-divided into capital recovery costs (depreciation and interest costs) and costs for property taxes, insurance, and administration. Depreciation and interest costs have been computed using

a capital recovery factor based on a 30 year internal floating roof life and an interest rate of 10% per annum. Costs for property taxes, insurance, and administration are computed at 4% of the capital costs. All annualized costs are for one year periods commencing with the second quarter of 1977.

4.2 CONTROL OF EMISSIONS FROM FIXED ROOF STORAGE TANKS

4.2.1 Model Cost Parameters

Emissions from fixed roof tanks are primarily working losses and breathing losses. The recommended control technique is to modify fixed roof tanks by retrofitting internal floating roofs equipped with closure seals. This control technique is expected to reduce emissions significantly (see Table 4-1, parts III and IV).

Cost parameters used in computing internal floating roof control costs are shown in Table 4-2. These parameters are based on actual cost data from an EPA contractor,⁶ equipment vendors,^{5,7} an oil and gas association,⁸ and EPA estimates.

4.2.2 Control Costs

Table 4-3 presents the estimated costs of controlling VOC emissions from the three model sizes of existing fixed roof storage tanks. The installed capital costs are the median industry costs of retrofitting internal floating roofs, equipped with closure seals, on the three model tanks. The costs of cleaning and degassing tanks, correction of tank defects and loss of use of tanks during retrofitting are not included in these costs. The annual operating and maintenance costs are estimates based on standard maintenance and inspection programs. The annualized capital charges consist

Table 4-2. COST PARAMETERS USED IN COMPUTING CONTROL COSTS

I. Petroleum Liquid Values:

Gasoline:^a \$100.60/m³

Crude Oil:^b \$73.60/m³

II. Internal Floating Roof With Closure Seal Values:

A. Installed Capital Cost Retrofitted on Fixed Roof Tank:^c

	<u>Small Tank</u>	<u>Medium Tank</u>	<u>Large Tank</u>
High (North East Coast):	\$17,000	\$33,000	\$60,000
Median (Mid-west):	\$15,000	\$31,000	\$57,000
Low (Gulf Coast):	\$12,000	\$28,000	\$53,000

B. Annual Maintenance Cost:^d

5% of installed capital cost plus annual inspection charge of 1% of installed capital cost.

C. Replacement Life:^e 30 years

^aAverage gasoline value based on price data from Reference 2 and Wall Street Journal, October 20, 21, and 24, 1977.

^bAverage crude oil value based on data from Reference 3. Assumes 50% of crude oil losses will be replaced with imported oil at \$91.35/m³ and 50% of losses will be replaced with domestic oil at actual average price of \$53.45/m³. Value also includes average transportation cost from wellhead or port per Reference 4 of \$1.25/m³.

^cAluminum pontoon type internal floater per Reference 5; retrofitted cost varies with geographic location because of different labor and transportation costs; costs of other types of internal floaters will be higher.

^dPer EPA estimate.

^eExpected replacement life per Reference 5.

Table 4-3. CONTROL COST ESTIMATES FOR MODEL EXISTING FIXED ROOF TANKS

Control Device	Internal Floating Roof and Closure Seal		
	15.2 m diameter 9.2 m height 1590 x 10 ³ l capacity	30.5 m diameter 12.2 m height 8750 x 10 ³ l capacity	45.7 m diameter 14.6 m height 23,850 x 10 ³ l capacity
Installed Capital Cost (\$000): ^a	15.0	31.0	57.0
Annual Operating and Maintenance Cost (\$000): ^b	0.9	1.8	3.4
Annualized Capital Charges (\$000): ^c	2.1	4.5	8.3
Total Annual Control System Cost (not including petroleum credits) (\$000): ^d	3.0	6.3	11.7

^aMedian installed costs of retrofitting internal floating roofs and closure seals on existing fixed roof tanks per references 5, 6, 7, and 8; does not include the costs of cleaning and degassing tanks, correction of tank defects and loss of use of tanks during retrofit.

^bPer EPA estimate.

^cCapital recovery costs (using capital recovery factor with 10% annual interest rate and 30 year internal floating roof life) plus 4% of installed capital cost for property taxes, insurance, and administration.

^dSum of annual operating and maintenance cost plus annualized capital charges; but, does not include petroleum credits (savings).

of the capital recovery costs (using capital recovery factor with 10% annual interest rate and 30 year internal floating roof life) plus 4% of installed capital cost for property taxes, insurance, and administration. The total annual control system costs are the sum of the annual operating and maintenance costs and the annualized capital charges. Annual petroleum credits from reducing emissions are not included in these totals, but are shown in the following section on cost effectiveness.

From Table 4-3, it should be noted that the median capital costs of internal floating roofs retrofitted on the small, medium size, and large model tanks are \$15,000, \$31,000 and \$57,000, respectively. Also, it may be seen that the total annual control system costs of the three model tanks are estimated as \$3,000, \$6,300, and \$11,700, respectively.

4.3 COST EFFECTIVENESS

Tables 4-4, 4-5, and 4-6, present the cost effectiveness ratios of controlling emissions from the three model sizes of existing fixed roof tanks. Separate ratios are presented for gasoline and crude oil emission control because of different economic values and emission rates of the two liquids. The emission reduction varies with true vapor pressure and throughput (the number of turnovers). Higher vapor pressure and a larger throughput will result in a greater quantity of controlled emissions and larger petroleum credits; opposite (low) values will result in a smaller quantity of emissions controlled and lesser petroleum savings. Since a range of the above controlling parameters is needed to cover the typical range of tank operating conditions and locations, cost effectiveness ratios have been determined using low, median, and high estimated values for the factors and control system costs.

Table 4-4. COST EFFECTIVENESS OF CONTROLLING SMALL FIXED ROOF TANK
 (15.2 m diameter; 9.2 m height;
 1590 x 10³ l capacity)

	Low		Median		High	
True Vapor Pressure (kPa)	13.8		41.4		69.0	
No. of Turnovers/year	5		10		20	
Petroleum Liquid Stored	Gasoline	Crude Oil	Gasoline	Crude Oil	Gasoline	Crude Oil
VOC Emission Reduction (Mg/yr) ^a	11.0	6.2	40.1	21.5	107	60.9
Annual Petroleum Savings (Credits) (\$000/yr) ^b	(1.7)	(0.9)	(6.0)	(2.9)	(16.0)	(8.3)
Total Annual Control System Cost (\$000/yr) ^c	2.4	2.4	3.0	3.0	3.5	3.5
Net Annual Cost/(credit) (\$000/yr) ^d	0.7	1.5	(3.0)	0.1	(12.5)	(4.8)
Cost (credit) per Mg of Controlled Emissions (\$/Mg) ^e	65	240	(75)	5	(115)	(80)

^a(Emissions Before Control) minus (Emissions After Control) per Table 4-1.

^b(VOC Emissions Controlled) x (Recovered Petroleum Liquid Value) ÷ (Average Liquid Density).

^cMedian values from Table 4-3; low and high values based on low and high costs per Reference 5.

^dSum of Annual Petroleum Savings (credits) and Total Annual Control System Cost.

^e(Net Annual Cost/(credit) ÷ (VOC Emissions Controlled).

Table 4-5. COST EFFECTIVENESS OF CONTROLLING MEDIUM SIZE FIXED ROOF TANK
(30.5 m diameter; 12.2 m height; 8750 x 10³ l capacity)

	Low		Median		High	
True Vapor Pressure (kPa)	13.8		41.4		69.0	
No. of Turnovers/year	5		10		20	
Petroleum Liquid Stored	Gasoline	Crude Oil	Gasoline	Crude Oil	Gasoline	Crude Oil
VOC Emission Reduction (Mg/yr) ^a	49.1	26.6	186	104	517	299
Annual Petroleum Savings (credits) (\$000/yr) ^b	(7.4)	(3.6)	(27.9)	(14.2)	(77.6)	(40.9)
Total Annual Control System Cost (\$000/yr) ^c	5.7	5.7	6.3	6.3	6.8	6.8
Net Annual Cost/(credit) (\$000/yr) ^d	(1.7)	2.1	(21.6)	(7.9)	(70.8)	(34.1)
Cost (credit) per Mg of Controlled Emissions (\$/Mg) ^e	(35)	80	(115)	(75)	(135)	(115)

^a(Emissions Before Control) minus (Emissions After Control) per Table 4-1.

^b(VOC Emissions Controlled) x (Recovered Petroleum Liquid Value) ÷ (Average Liquid Density).

^cMedian values from Table 4-3; low and high values based on low and high costs per Reference 5.

^dSum of Annual Petroleum Savings (credits) and Total Annual Control System Cost.

^e(Net Annual Cost/(credit) ÷ (VOC Emissions Controlled).

Table 4-6. COST EFFECTIVENESS OF CONTROLLING LARGE FIXED ROOF TANK
(45.7 m diameter; 14.6 m height; 23,850 x 10³ l capacity)

	Low		Median		High	
True Vapor Pressure (kPa) ^a	13.8		41.4		69.0	
No. of Turnovers/year	5		10		20	
Petroleum Liquid Stored	Gasoline	Crude Oil	Gasoline	Crude Oil	Gasoline	Crude Oil
VOC Emission Reduction (Mg/yr) ^a	118	64.1	466	266	1320	775
Annual Petroleum Savings (Credits) (\$000/yr) ^b	(17.7)	(8.7)	(69.9)	(36.3)	(198.0)	(105.7)
Total Annual Control System Cost (\$000/yr) ^c	10.9	10.9	11.7	11.7	12.4	12.4
Net Annual Cost/(credit) (\$000/yr) ^d	(6.8)	2.2	(58.2)	(24.6)	(185.6)	(93.3)
Cost (credit) per Mg of Controlled Emissions (\$/Mg) ^e	(60)	35	(125)	(90)	(140)	(120)

^a(Emissions Before Control) minus (Emissions After Control) per Table 4-1.

^b(VOC Emissions Controlled) x (Recovered Petroleum Liquid Value) ÷ (Average Liquid Density).

^cMedian values from Table 4-3; low and high values based on low and high costs per Reference 5.

^dSum of Annual Petroleum Savings (Credits) and Total Annual Control System Cost.

^e(Net Annual Cost/(credit) ÷ (VOC Emissions Controlled).

From Table 4-4, it can be observed that the cost effectiveness of the small model tank varies from a credit of \$115 to a cost of \$65 per Mg of controlled gasoline emissions. The corresponding cost effectiveness ratios for crude oil emission control range from a credit of \$80 to a cost of \$240 per Mg. Similarly, from Table 4-5, it can be seen that the cost effectiveness of the median size model tank ranges from a credit of \$135 for gasoline to a cost of \$80 for crude oil per Mg of controlled emissions; and from Table 4-6, the cost effectiveness of the large model tank varies from a credit of \$140 per Mg for gasoline to a cost of \$35 per Mg for crude oil emission control.

Figure 4-1 graphically depicts the estimated cost effectiveness curves of controlling gasoline emissions and Figure 4-2 shows the similar curves of controlling crude oil emissions. As would be expected, the curves show that larger tanks are more cost effective than smaller tanks. Also, for each tank size, the use of low values result in less favorable ratios and vice versa. From Figure 4-1, it should be noted that the control of all tank sizes should result in a savings (credit), except when low values apply to tanks smaller than about $5,000 \times 10^3$ l. From Figure 4-2, it can be seen that control of all tank sizes should result in a savings if high values are appropriate or in a cost if low values pertain. But, if median values apply, then control of tanks larger than about $2,000 \times 10^3$ l should result in a credit while control of smaller tanks should be a cost.

Figure 4-1. Cost Effectiveness of Controlling Emissions From Existing Fixed Roof Gasoline Tanks

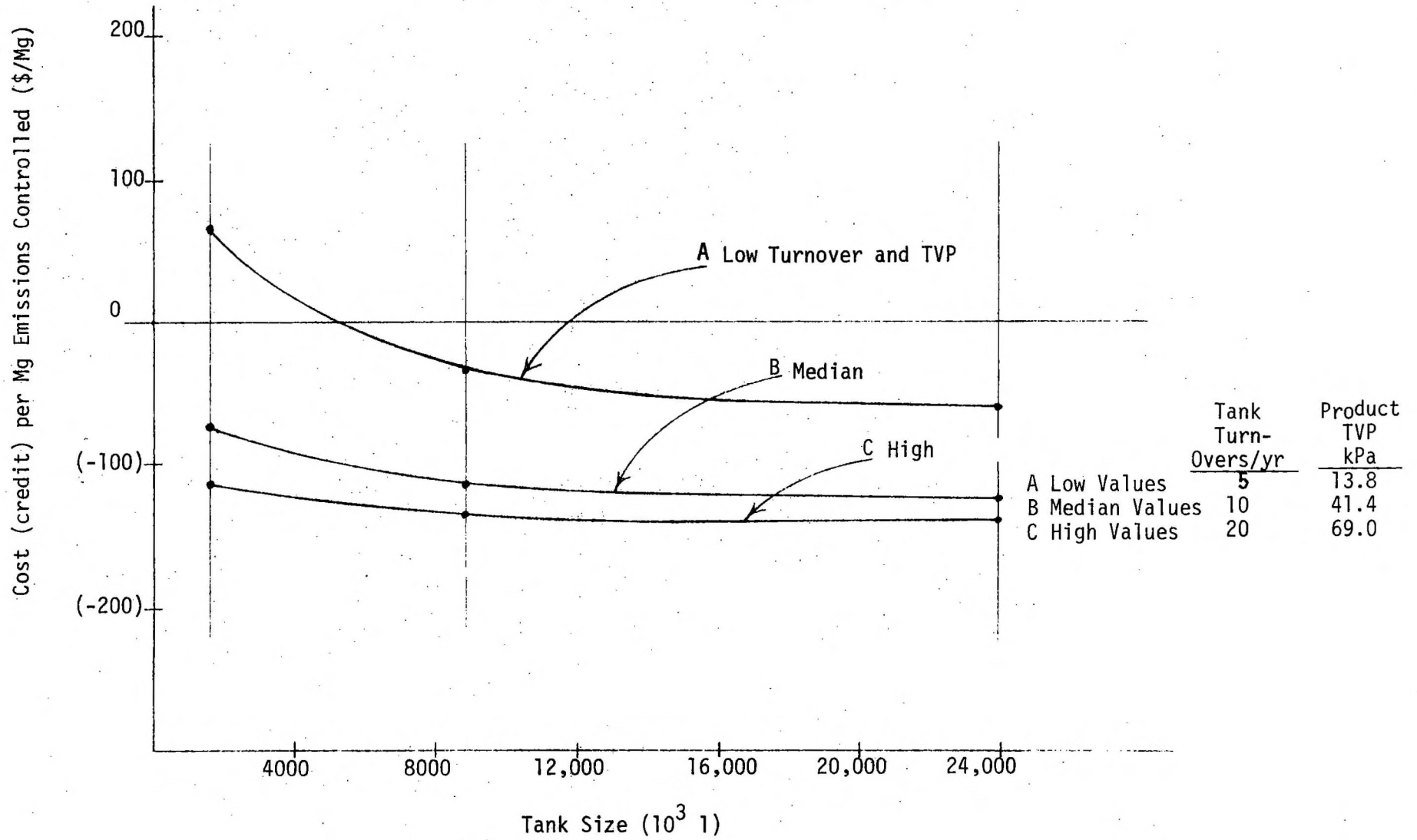
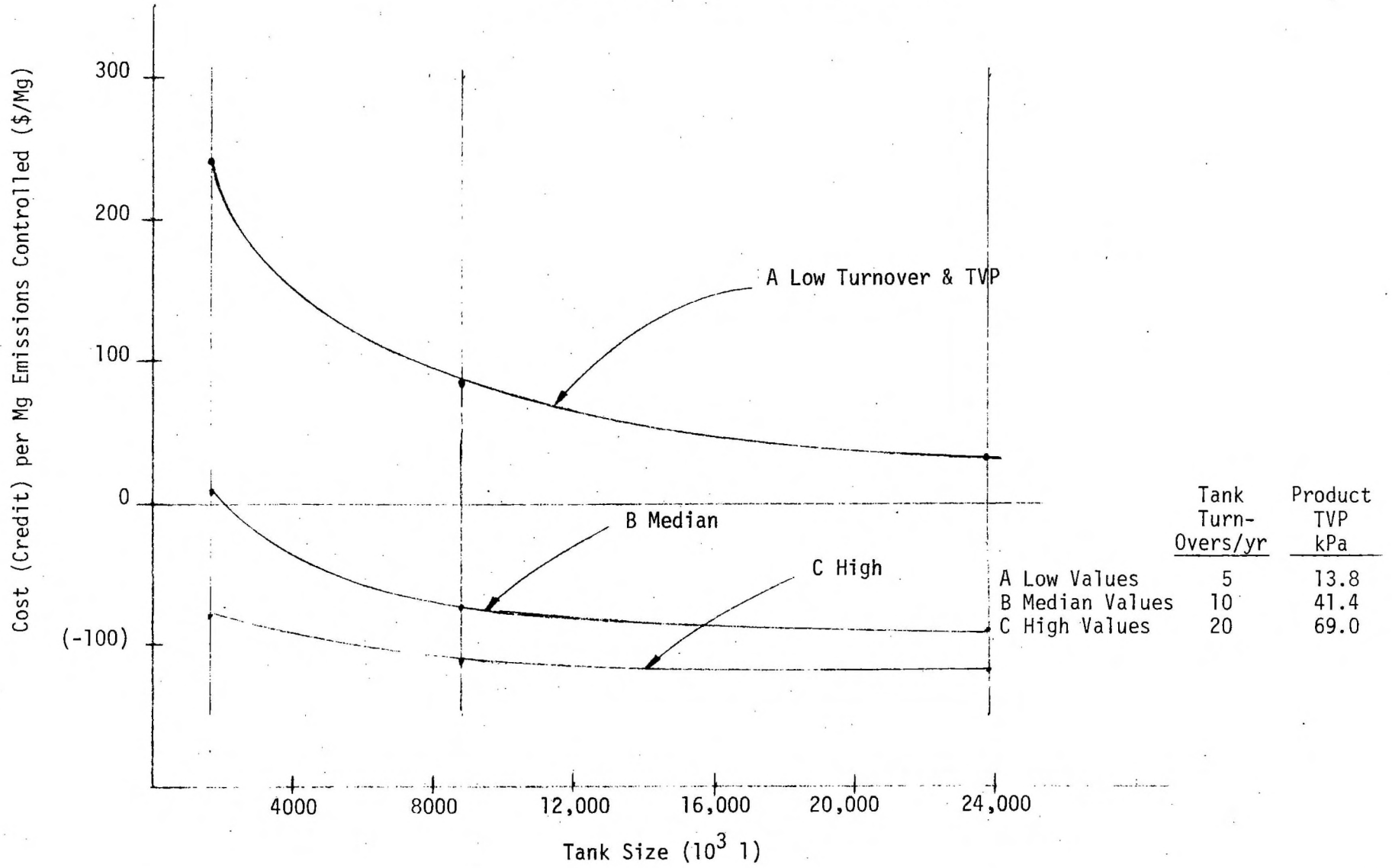

Figure 4-2. Cost Effectiveness of Controlling Emissions From Existing Fixed Roof Crude Oil Tanks



4.4 REFERENCES

1. Gasoline and Crude Oil Emissions Before and After Control, calculated per AP-42, Supplement No. 7.
2. "Refined-products prices", Oil and Gas Journal, October 17, 1977.
3. Monthly Energy Review, August, 1977, Office of Energy Information and Analysis, National Energy Information Center.
4. Dr. W. Sheppard, Battelle Columbus Laboratories, Columbus, Ohio. Petroleum liquids transportation cost data memo to file by R. A. Quaney, U.S. Environmental Protection Agency, dated November 2, 1977.
5. R. C. Kern, Ultra-flote Corp., Houston, Texas. Internal floating roof cost data memos to file by R. A. Quaney, U.S. Environmental Protection Agency, dated November 7, 1977 and December 20, 1977.
6. Evaluation of Hydrocarbon Emissions From Petroleum Liquid Storage, Pacific Environmental Services, Inc., Santa Monica, Cal., EPA-450/3-78-012, March, 1978.
7. K. J. Kolkmeier, Pittsburgh-Des Moines Steel Co., Pittsburgh, Pa. Internal floating roof cost data memos to file by R. A. Quaney, U.S. Environmental Protection Agency, dated November 9, 1977 and December 23, 1977.
8. Survey of Costs to Install Floating Roofs by Louisiana Division members of Mid-Continent Oil and Gas Association, January 14, 1977.

5.0 EFFECTS OF APPLYING THE TECHNOLOGY

The impacts on air pollution, water pollution, solid waste, and energy are discussed in this chapter.

5.1 AIR POLLUTION IMPACTS

Estimated VOC emissions from fixed roof tanks (>150,000 liter capacity) during 1976 are about 560,000 Mg/yr.¹ This represents about 3 percent of total nationwide VOC losses from stationary sources.

Emissions from these fixed roof tanks could be reduced to less than 56 Mg/yr by retrofitting fixed roof tanks with internal floating roofs.

Emissions from existing external floating roof tanks and internal floating roof tanks are estimated at 134,000 Mg/yr. This is 1 percent of the total estimated hydrocarbon emissions from stationary sources.

5.2 OTHER EFFECTS

EPA has examined the impacts of applying control techniques to the storage of petroleum liquids and has determined that there are no significant adverse effects on water pollution, solid waste, or energy.

5.3 REFERENCE

1. Evaluation of Hydrocarbon Emission from Petroleum Liquid Storage, Pacific Environmental Services, Inc., EPA-450/3-78-012, March, 1978.

6.0 RECOMMENDED REGULATIONS, COMPLIANCE TEST METHOD AND RECORD KEEPING

The affected facilities are fixed roof storage tanks with capacities greater than 150,000 liters containing petroleum liquids with a true vapor pressure greater than 10.5 kPa.

6.1 RECOMMENDED REGULATIONS

Recommended regulations for the storage of petroleum liquids in fixed roof tanks are:

1. All fixed roof tanks with capacities greater than 150,000 liters storing volatile petroleum liquids (greater than 10.5 kPa TVP) should be retrofitted as follows, except where exempted:

- (a) Internal floating roofs equipped with a closure seal or seals, or
- (b) alternative equivalent control.

2. There are to be no visible holes, tears, or other openings in the seal or any seal fabric.

3. Where applicable:

All openings, except stub drains, are to be equipped with a cover, seal or lid. The cover, seal or lid is to be in a closed position at all times except when the device is in actual use. Automatic bleeder vents are to be closed at all times except when the roof is floated off or landed on the roof leg supports. Rim vents, if provided, are to be set to open when the roof is being floated off the roof leg supports or at the manufacturer's recommended setting.

4. Fixed roof tanks having capacities less than 1,600,000 liters used to store produced crude oil and condensate prior to lease custody transfer are exempted.

6.2 COMPLIANCE TEST METHOD

Determining compliance for fixed roof petroleum storage tanks equipped with an internal floating roof should be by visual inspection of the floating cover through the roof hatches. The cover should be uniformly floating on or above the liquid and there should be no visible defects in the surface of the cover or liquid accumulated on the cover. The seal must be intact and uniformly in place around the circumference of the cover between the cover and tank wall.

6.3 MONITORING AND RECORD KEEPING

It is recommended that routine inspections through the roof hatches be conducted at six month or shorter intervals. Evidence of any type of malfunction (as noted above) is to be recorded. Whenever the tank is emptied for non-operational reasons such as maintenance, an emergency, or other similar purposes (such as a Department of Transportation Inspection), a complete inspection of the cover and seal is to be made and the condition of the cover and seal recorded. The control agency should be notified prior to a complete inspection.

A record should be maintained of the average monthly storage temperature and true vapor pressure of the petroleum liquid stored if the product has a stored true vapor pressure greater than 7.0 kPa and is stored in a fixed roof tank not equipped with an internal floating cover or alternative equivalent control device installed under 6.1.1.b above. The true vapor pressure may be determined by using the average monthly storage temperature and typical

Reid vapor pressure of the stored product. Supporting analytical data can be requested if there is a question on the values report for any product.

TECHNICAL REPORT DATA
(Please read Instructions on the reverse before completing)

1. REPORT NO. EPA-450/2-77-036		2.	3. RECIPIENT'S ACCESSION NO.	
4. TITLE AND SUBTITLE Control of Volatile Organic Emissions From Storage of Petroleum Liquids in Fixed Roof Tanks			5. REPORT DATE December, 1977	
			6. PERFORMING ORGANIZATION CODE	
7. AUTHOR(S) Richard K. Burr, ESED Robert Quaney, SASD Kerri C. Brothers, ESED			8. PERFORMING ORGANIZATION REPORT NO. OAQPS 1.2-089	
9. PERFORMING ORGANIZATION NAME AND ADDRESS U. S. Environmental Protection Agency Office of Air and Waste Management Office of Air Quality Planning and Standards Research Triangle Park, N.C. 27711			10. PROGRAM ELEMENT NO.	
			11. CONTRACT/GRANT NO.	
12. SPONSORING AGENCY NAME AND ADDRESS			13. TYPE OF REPORT AND PERIOD COVERED	
			14. SPONSORING AGENCY CODE	
15. SUPPLEMENTARY NOTES				
16. ABSTRACT This report provides the necessary guidance for development of regulations limiting emissions of volatile organic compounds (VOC) from the storage of petroleum liquids in fixed roof tanks. Reasonably available control technology (RACT) is defined in this document; cost analysis for RACT is included for evaluating the cost effectiveness of controlling fixed roof storage tank sources.				
17. KEY WORDS AND DOCUMENT ANALYSIS				
a. DESCRIPTORS		b. IDENTIFIERS/OPEN ENDED TERMS		c. COSATI Field/Group
Air Pollution Storage Tanks Regulatory Guidance		Air pollution control Stationary sources Organic vapors		
18. DISTRIBUTION STATEMENT		19. SECURITY CLASS (This Report) Unclassified		21. NO. OF PAGES 48
		20. SECURITY CLASS (This page) Unclassified		22. PRICE

ENVIRONMENTAL PROTECTION AGENCY
General Services Division (MD-28)
Office of Administration
Research Triangle Park, North Carolina 27711

POSTAGE AND FEES PAID
ENVIRONMENTAL PROTECTION AGENCY
EPA-335



OFFICIAL BUSINESS
AN EQUAL OPPORTUNITY EMPLOYER

Return this sheet if you do NOT wish to receive this material
or if change of address is needed . (Indicate change, including
ZIP code.)

PUBLICATION NO. EPA-450/2-77-036
(OAQPS No. 1.2-089)