

**REGION 6
UNDERGROUND INJECTION CONTROL
CLASS VI PERMIT**

**PERMIT ID: R6-TX-135-C6-0002
WELL NAME: BRP CCS2**



ISSUED TO:
Oxy Low Carbon Ventures, LLC (OLCV)
5 Greenway Plaza,
Houston, TX 77046

TABLE OF CONTENTS

PERMIT CONDITIONS 6

 A. EFFECT OF PERMIT..... 6

 B. PERMIT ACTIONS 6

 C. SEVERABILITY 7

 D. CONFIDENTIALITY 7

 E. DEFINITIONS 8

 F. DUTIES AND REQUIREMENTS 8

 G. AREA OF REVIEW AND CORRECTIVE ACTION 12

 H. FINANCIAL RESPONSIBILITY 14

 I. WELL CONSTRUCTION REQUIREMENTS 17

 J. PRE-INJECTION TESTING 19

 K. INJECTION WELL OPERATION 21

 L. MECHANICAL INTEGRITY 24

 M. TESTING AND MONITORING..... 27

 N. REPORTING AND RECORDKEEPING 55

 O. WELL PLUGGING, POST-INJECTION SITE CARE, AND SITE CLOSURE 60

 P. EMERGENCY AND REMEDIAL RESPONSE 63

 Q. SEISMIC EVENT RESPONSE 65

 R. COMMENCING INJECTION..... 66

ATTACHMENTS..... 67

ATTACHMENT 1: SUMMARY OF OPERATING REQUIREMENTS 68

ATTACHMENT 2: AREA OF REVIEW AND CORRECTIVE ACTION PLAN 74

ATTACHMENT 3: FINANCIAL RESPONSIBILITY DEMONSTRATION 114

ATTACHMENT 4: CONSTRUCTION DETAILS 118

ATTACHMENT 5: STIMULATION PLAN 136

ATTACHMENT 6: TESTING AND MONITORING PLAN..... 140

ATTACHMENT 7: WELL PLUGGING PLAN..... 202

ATTACHMENT 8: POST-INJECTION SITE CARE AND SITE CLOSURE PLAN 212

ATTACHMENT 9: EMERGENCY AND REMEDIAL RESPONSE PLAN 225



REGION 6

DALLAS, TX 75270

**UNITED STATES ENVIRONMENTAL PROTECTION AGENCY UNDERGROUND INJECTION
CONTROL PERMIT: CLASS VI**

Permit Number: R6-TX-135-C6-0002

Facility Name: Brown Pelican CCS2

Under the authority of the Safe Drinking Water Act (SDWA) and Underground Injection Control (UIC) Program regulations of the U. S. Environmental Protection Agency (EPA) codified at Title 40 of the Code of Federal Regulations (40 CFR) parts 2, 124, 144, and 146 and according to the terms of this Permit,

Oxy Low Carbon Ventures, LLC

hereinafter referred to as the "Permittee," is authorized to construct and, upon issuance of authorization, to commence injection, to operate the following Class VI well:

BRP CCS2
Penwell, TX
Latitude: 31.76993805
Longitude: -102.7332448

This well will inject one carbon dioxide stream (carbon dioxide is also called CO₂ in the attachments to this permit) sourced from the Stratos direct air capture facility in Ector County, Texas. The Permittee may request to inject carbon dioxide from additional emission sources in the future, subject to review and approval by EPA, as described in Section N of this Permit.

The carbon dioxide stream, as characterized in the permit application and the administrative record, shall be a supercritical fluid. Injection for this horizontal well is authorized into the Lower San Andres Formation at a depth of approximately 4,674 feet to 6,069 feet measured depth (MD)/4,479 feet to 5,177 feet total vertical depth (TVD) upon the express condition that the Permittee meets the restrictions set forth herein. The designated upper confining zones for

this injection are the Upper San Andres and Grayburg Formations (combined), and the lower confining zone is the Glorieta Formation.

Executive Order 12898, 59 Fed. Reg. 7629 (Feb. 11, 1994), *Federal Actions to Address Environmental Justice in Minority Populations and Low-Income Populations*, directs federal agencies to identify and address as appropriate, to the greatest extent practical and permitted by law, disproportionate and adverse environmental and human health impacts on people of color and low-income populations. Executive Order 14096, 88 Fed. Reg. 25251 (Apr. 21, 2023), *Revitalizing Our Nation's Commitment to Environmental Justice for All*, supplemented this direction. EPA considered these executive orders and EPA's Environmental Justice Guidance for UIC Class VI Permitting and Primacy (August 17, 2023) as part of the review for this Permit.

This permit is for the construction and operation of one Class VI injection well. Injection shall not commence until the Permittee has received written authorization to inject from the Director of the Water Division of EPA Region 6 (Director), in accordance with Section R of this Permit.

Any underground injection activity not authorized by this Permit is prohibited. All references to 40 CFR are to the regulations in effect on the date that this Permit is effective and, should renumbering occur, their subsequent equivalent. The following attachments are excerpts of specific elements from the Permittee's application that are incorporated into this permit for reference and as enforceable conditions:

1. Summary of Operating Requirements
2. Area of Review (AoR) and Corrective Action Plan
3. Financial Responsibility Demonstration
4. Construction Details
5. Stimulation Program
6. Testing and Monitoring Plan
7. Well Plugging Plan
8. Post-Injection Site Care and Site Closure Plan
9. Emergency and Remedial Response Plan

Compliance with the terms of this Permit does not constitute a defense to any enforcement action brought under the provisions of Section 1431 of the SDWA or any other law governing the protection of public health or the environment, nor does it serve as a shield to the Permittee's independent obligation to comply with all applicable UIC regulations.

This Permit shall become effective thirty days after notice of issuance, subject to the conditions in Section A. ("Effect of Permit"), and shall remain in full force and effect during the operating life of the well and the post-injection site care period until site closure is authorized and completed unless this Permit is revoked and reissued, terminated, or modified pursuant to 40 CFR 124.5, 144.12, 144.39, 144.40 or 144.41. This Permit shall also remain in effect upon

delegation of primary enforcement responsibility to a new entity until such time as the new entity issues its own permit to the Permittee or the new entity chooses to adopt this Permit as its permit.

The permit will expire in two years if the permittee fails to commence construction on the well unless the Director approves a written request in electronic format for an extension of this two-year period. Requests for extension must state delay causality, an estimated well completion date, and list additional wells that penetrate the designated confining zone within the Area of Review (AoR) which were not included in the initial permit application, including well construction diagrams, cement records, and cement bond logs for any new AoR wells. The permittee may request an expiration date sooner than the two-year period, provided no construction on the well has commenced.

The permittee must reevaluate the AoR and comply with 40 CFR 146.84(e) at least every five years from the effective date specified above. If the results from the reevaluated AoR are different from what is predicted in the Permittee's application, the EPA may require the permittee to update their permit application within the Geologic Sequestration Data Tool (GSDT).

Authorization Signed By:

Troy C. Hill, P.E.
Director, Water Division
Date Signed:

DATE

PERMIT CONDITIONS

A. EFFECT OF PERMIT

The Permittee is allowed to engage in underground injection in accordance with the conditions of this Permit and with an authorization to inject. Notwithstanding any other provisions of this Permit, the Permittee authorized by this Permit must not construct, operate, maintain, convert, plug, abandon, or conduct any other injection activity in a manner that allows the movement of injection, annulus, or formation fluids into underground sources of drinking water (USDWs) or any unauthorized geologic zones. The objective of this Permit is to prevent the movement of fluids into or between USDWs or into any unauthorized geologic zones consistent with the requirements at 40 CFR 146.86(a) and 144.12(a) and (b). Any underground injection activity not explicitly authorized in this Permit is prohibited. For purposes of enforcement, compliance with this Permit during its term constitutes compliance with Part C of the Safe Drinking Water Act (SDWA). Such compliance does not constitute a defense to any action brought under Section 1431 of the SDWA or any other common or statutory law other than Part C of the SDWA.

Issuance of this permit does not convey property rights of any sort or any exclusive privilege; nor does it authorize any injury to persons or property, any invasion of other private rights, or any infringement of State or local laws or regulations. Nothing in this permit, nor compliance with its terms, shall be construed to relieve the permittee of any duties under applicable federal, state or local laws or regulations that are not preempted or superseded by the federal SDWA Underground Injection Control (UIC) program.

In accordance with 40 CFR 124.15(b), the effective date of the permit is thirty days after notice of issuance, except that the permit shall not become effective (1) until the financial responsibility demonstration in Attachment 3 is fully effective or (2) if the permit is appealed pursuant to 40 CFR 124.19. If the permit is appealed, the effectiveness of uncontested and several conditions is governed by the procedures at 40 CFR 124.16.

B. PERMIT ACTIONS

1. **Modification, Revocation, and Reissuance, or Termination:** The Director may, for cause or upon request from any interested person, including the Permittee, modify, revoke and reissue, or terminate this Permit in accordance with 40 CFR 124.5, 144.12, 146.86(a), 144.39, and 144.40.
2. **Minor Modifications:** Upon the consent of the Permittee, the Director may modify this Permit to make the corrections or allowances for minor changes in the permitted

activity as listed in 40 CFR 144.41. Any permit modification not processed as a minor modification under 40 CFR 144.41 must be made for cause and follow the procedures in 40 CFR 124 for preparing a draft permit and issuing public notice, as required in 40 CFR 144.39.

3. **Transfer of Permit**: This permit is not transferable to any person except in accordance with 40 CFR 144.38(a) and Section N(6)(b) of this permit.
4. **Permittee Change of Name or Address**: The Permittee shall notify the Director at least 30 days in advance of changes in the Permittee's legal name, address, or address where records are kept. The Permit may be subject to a modification in accordance with item (1) of this section.
5. **Injection Well Conversion**: The Permittee shall notify the Director at least 30 days in advance of planned well conversion to another type of injection or non-injection well. The notice shall include the type of well to which the existing well will be converted and a completed 7520-19 form or its equivalent. Such notice shall also include a demonstration that the existing injection well has internal and external mechanical integrity (MI) and documentation that the agency with regulatory authority over the new well type has been notified. The Permittee must provide a representative of the regulatory agency the opportunity to attend the MI testing by notifying the Director at least 30 days in advance of the MI testing. The Permittee shall not begin conversion of the well without written approval from the Director that the requirements of this Permit have been met, nor without a proper and approved UIC permit/authorization if the well is being converted to a different type of injection well. Upon conversion, the Permittee shall convert the well(s) in a manner that will not allow the movement of fluids into or between USDWs. The Permittee shall also ensure that the conversion meets all applicable federal, state, and local requirements. The Permittee must continue to comply with all Permit requirements until the Permit expires, unless the Permittee receives written approval from the Director waiving such requirements.

C. SEVERABILITY

The provisions of this Permit are severable, and if any provision of this Permit or the application of any provision of this Permit to any circumstance is held invalid, the application of such provision to other circumstances and the remainder of this Permit shall not be affected thereby.

D. CONFIDENTIALITY

In accordance with 40 CFR Part 2 (Public Information) and 40 CFR 144.5, any information submitted to EPA under this Permit may be claimed as containing trade secret, proprietary, or confidential business information which is protected under Exemption 4 of the Freedom of Information Act at 5 U.S.C. 552(b)(4) by the submitter. Any such claim must be asserted at the time of submission by clearly marking the words "confidential business information" or "proprietary business information" on every page containing such information. Also, the Permittee shall provide a detailed report substantiating all such claims. The report should include but not be limited to information on why disclosure would cause harm, the portions of information entitled to confidential treatment, etc. If no claim is made at the time of submission, EPA may make the information available to the public without further notice. If a claim is asserted, the validity of the claim will be treated in accordance with the procedures in 40 CFR Part 2. Claims of confidentiality for the following information will be denied:

1. The name and address of the Permittee; and
2. Information that deals with the existence, absence, or level of contaminants in drinking water.

E. DEFINITIONS

All terms used in this Permit shall have the meaning set forth in the SDWA and UIC regulations specified at 40 CFR parts 124, 144, 146, and 147. Unless expressly stated otherwise, all references to "days" in this permit should be interpreted as calendar days.

F. DUTIES AND REQUIREMENTS

1. **Prohibition of Movement of Fluid into a USDW:** The Permittee must not construct, operate, maintain, convert, plug, abandon, or conduct any injection activity in a manner that allows the movement of a fluid containing any contaminant into USDWs. If any water quality monitoring of a USDW indicates that a well covered by this permit may have caused the movement of any contaminant into the USDW, the Director may take enforcement action or prescribe such additional requirements for construction, corrective action, operation, monitoring, or reporting (including closure of the injection well) as are necessary to remediate and prevent such movement. The Director may also take enforcement action per 40 CFR 144.12(a), (b), and (e).
2. **Duty to Comply:** The Permittee must comply with all conditions of this Permit. Any permit noncompliance constitutes a violation of the SDWA and is grounds for enforcement action, permit termination, revocation, reissuance, modification, or denial of a permit renewal application, except that the Permittee need not comply with the

provisions of this Permit to the extent and for the duration as such noncompliance is authorized in an emergency permit under 40 CFR 144.34 and 144.51(a).

3. **Duty to Reapply**: If the Permittee wishes to continue an activity regulated by this Permit after its expiration, the Permittee must apply for and obtain a new permit, per 40 CFR 144.51(b).
4. **Penalties for Violations of Permit Conditions**: Any person who violates a permit requirement is subject to civil penalties and other enforcement action under the SDWA, 42 USC 300h-2. Any person who willfully violates permit conditions may be subject to criminal prosecution under the SDWA and other applicable statutes and regulations.
5. **Need to Halt or Reduce Activity Not a Defense**: It shall not be a defense for the Permittee in an enforcement action to claim that it would have been necessary to halt or reduce the permitted activity to maintain compliance with the conditions of this Permit per 40 CFR 144.51(c). Enforcement actions may require the Permittee to halt or reduce injection activities.
6. **Duty to Mitigate**: The Permittee shall take all timely and reasonable steps necessary to minimize or correct any adverse environmental impact resulting from noncompliance with this Permit under 40 CFR 144.51(d).
7. **Actions not Authorized**: Issuance of this Permit does not convey property rights of any sort or any exclusive privilege per 40 CFR 144.51(g); nor does it authorize any injury to persons or property, any invasion of other private rights, or any infringement of state or local laws or regulations. Nothing in this Permit, nor compliance with its terms, shall be construed to relieve the Permittee of any duties under State or local laws or regulations that are not preempted or superseded by the federal SDWA UIC program.
8. **Enforceability during Modification**: The filing of a request for a permit modification, revocation, reissuance, termination, notification of planned changes, or anticipated noncompliance on the part of the Permittee does not stay the applicability or enforceability of any condition of this Permit, per 40 CFR 144.51(f). The Permittee shall notify the Director at least 30 days in advance of any modification for review and approval prior to the modification activity.
9. **Proper Operation and Maintenance**: The Permittee shall always properly operate and maintain all facilities and systems of treatment and control (and related appurtenances) that are installed or used by the Permittee to achieve compliance with the conditions of this Permit. Proper operation and maintenance include effective performance, adequate funding, adequate Permittee staffing and training, accurate laboratory and process controls, and appropriate quality assurance procedures. This

provision requires the operation of backup or auxiliary facilities or similar systems only when necessary to comply with this Permit's conditions per 40 CFR 144.51(e).

10. **Duty to Provide Information:** The Permittee shall furnish to the Director in electronic format, within the time specified by the type of submittal or as defined by the Director, any information that the Director may request to determine whether cause exists for modifying, revoking, and reissuing, or terminating this Permit, or to determine compliance with this Permit or the UIC regulations. The Permittee shall also furnish to the Director, upon request within a time specified, electronic copies of records required to be kept by this Permit. The Permittee shall also comply with all reporting requirements of this Permit, as specified in Section N, and as required by 40 CFR 144.32 and 144.51(h).

11. **Inspection and Entry:** The Permittee shall allow the Director or an authorized representative, upon the presentation of credentials and other documents as may be required by law, under 40 CFR 144.51(i):
 - a. Entry upon the Permittee's premises where a regulated facility or activity is located or conducted, or where electronic or non-electronic records must be kept under the conditions of this Permit;
 - b. Have access to and copy, at reasonable times, any records which are required to be kept under the conditions of this Permit;
 - c. Inspect, at reasonable times, any facilities, equipment (including monitoring and control equipment), practices, or operations regulated or required under this Permit; and
 - d. Sample or monitor, at reasonable times, for the purposes of assuring permit compliance or as otherwise authorized by the SDWA, any substances or parameters at any location, including facilities, equipment, or operations regulated or required under this Permit.

12. **Signatory and Certification Requirements:** All reports, notifications, or any other information, required to be submitted by this Permit or requested by the Director shall be signed and certified in accordance with 40 CFR 144.32. The Permittee shall ensure that all signed documents include the following certification statement: *"I certify under penalty of law that this document and all attachments were prepared under my direction or supervision in accordance with a system designed to assure that qualified personnel properly gather and evaluate the information submitted. Based on my inquiry of the person or persons who manage the system, or those persons directly responsible for gathering the information, the information submitted is, to the best of my knowledge*

and belief, true, accurate, and complete. I am aware that there are significant penalties for submitting false information, including the possibility of fine and imprisonment for knowing violations."

G. AREA OF REVIEW AND CORRECTIVE ACTION

The Permittee shall maintain and comply with the approved Area of Review (AoR) and Corrective Action Plan (CAP) referenced in Attachment 2 and shall meet the requirements of 40 CFR 146.84. In accordance with this Permit and UIC regulations, the Permittee shall do the following:

1. The AoR is the region surrounding the geologic sequestration project where USDWs may be endangered by the injection activity. The AoR is delineated using computational modeling that accounts for the physical and chemical properties of all phases of the injected carbon dioxide stream and is based on available site characterization, monitoring, and operational data. The permittee shall maintain and comply with the approved Area of Review and Corrective Action Plan, which is an enforceable condition of this permit and shall meet the requirements of 40 CFR 146.84.
2. As delineated in Attachment 2, three wellbores within the AoR require plugging because the wellbores penetrate the injection zone or confining layer and will not be used for injection or monitoring within the storage project. The wells are required to be properly plugged and abandoned prior to authorization of carbon dioxide injection (40 CFR 146.84(d)). The Permittee must provide notice in an electronic format 30 days prior to plugging the wells and must provide the Director or their representative the opportunity to attend.
3. At least sixty (60) days prior to commencing corrective action, the Permittee shall submit procedures for performing corrective action on the identified deficient wells within the AoR and not commence any corrective action until the procedures are approved by the Director, if not already submitted and approved (40 CFR 146.82(a)(13)).
 - a. As corrective action activities are completed, the permittee shall provide the Director with periodic updates and as requested, including plugging reports.
 - b. Corrective action on all deficient wells in the AoR must be complete and approved in writing by EPA before the permittee may commence injection pursuant to Section R of this permit and 40 CFR 146.82(c)(6)).
4. At a minimum frequency not to exceed every 5 years as specified in the AoR and CAP, or more frequently when monitoring and operational conditions warrant, the Permittee must reevaluate the AoR and perform corrective action in the manner specified in 40 CFR 146.84 and update the AoR and CAP or demonstrate to the Director that no update is needed. Reevaluation of the AoR and CAP must meet the requirements of 40 CFR

146.84(e) and must include a new survey of wells identifying the names and locations of all wells within the existing or modified AoR.

5. Following each AoR reevaluation, the permittee shall submit the resultant information (i.e., the completed reevaluation analysis, along with either a revised AoR and CAP or a demonstration that the reevaluation analysis determined no revised Plan is needed) in an electronic format to the Director for review and approval. If a revised AoR and Corrective Action Plan is submitted and approved by the Director, the revised Plan becomes an enforceable condition of this permit (40 CFR 146.84(e)(4)). If the Director does not approve the revised AoR and Corrective Action Plan, injection operations cannot continue or be resumed.
6. Included with the submittal of a revised AoR and Corrective Action Plan, the permittee shall submit an updated analysis using EJScreen or other environmental impact screening method that incorporates the revised AoR boundary.
7. If the Permittee requests an extension to the permit expiration due to delayed construction, the Director may request information to update the Permit. Depending on the conditions of the delay, the Director may require a permit modification.

H. FINANCIAL RESPONSIBILITY

The Permittee must demonstrate and maintain financial responsibility in accordance with 40 CFR 146.85 to cover estimated costs. The approved financial responsibility documents and estimated costs for this Permit are referenced in Attachment 3 of this Permit. The Permittee must submit qualifying financial responsibility instrument(s). No substitution of a demonstration of financial responsibility shall become effective until the Permittee receives notification from the Director that the alternative demonstration of financial responsibility is acceptable. The Permittee must provide any updated information related to their financial responsibility instrument(s) on an annual basis to the Director and if there are any changes. The Permittee must comply with financial responsibility requirements regardless of the status of the Director's review of the financial responsibility demonstration. The requirement to maintain adequate financial responsibility and resources is directly enforceable regardless of whether the requirement is a condition of the permit.

1. **Cost Estimate Updates and Adjustments:** During the life of the geologic sequestration (GS) project, the Permittee shall maintain a current detailed written cost estimate to reflect adjustments for inflation costs and any amendments made to the Project Plans included as Attachments of this Permit. The Permittee shall submit updates, adjustments, and amendments to the cost estimates as follows:
 - a. Annually, within 60 days prior to the anniversary date of the establishment of the financial instrument. This estimate must account for annual inflation.
 - b. Within 60 days of any amendment to the area of review and corrective action plan (40 CFR 146.84), the injection well plugging plan (40 CFR 146.92), the post-injection site care and site closure plan (40 CFR 146.93), and/or the emergency and remedial response plan (40 CFR 146.94).
 - c. No later than 60 days after the Director has approved the request to modify the area of review and corrective action plan (40 CFR 146.84), the injection well plugging plan (40 CFR 146.92), the post-injection site care and site closure plan (40 CFR 146.93), and/or the emergency and response plan (40 CFR 146.94), if the change in the plan increases the cost.
 - d. Within 60 days of notification from the Director that the most recent financial responsibility demonstration is no longer adequate to cover the current estimated costs.
 - e. Cost estimates must be based on the costs of hiring a third party independent of the permittee's corporate structure to perform the required activities.

- f. The Permittee must obtain approval from the Director for any new or updated cost estimate or revised financial instrument. The Permittee shall submit qualifying revised financial responsibility instrument(s) that cover the new or updated costs within 60 days of any amendment(s).
 - g. The Permittee must obtain approval from the Director to decrease the value of the financial assurance instrument or withdraw funds if a change to the plans decreases the cost.
2. **Adverse Financial Conditions Notification (40 CFR 146.85(d))**: The Permittee shall notify the Director by certified mail and by email of adverse financial conditions that may affect the ability to cover current cost estimates.
- a. **Bankruptcy and/or Insolvency of the Permittee**: If the Permittee or the third-party provider of a financial responsibility instrument is going through a bankruptcy, the Permittee shall notify the Director within 10 days after commencement of a voluntary or involuntary proceeding under Title 11 (Bankruptcy), U.S. Code, naming the Permittee as the debtor. A guarantor of a corporate guarantee must make such a notification if he or she is named as debtor, as required under the terms of the guarantee.
 - b. **Bankruptcy, Insolvency, Suspension, or Loss of Authority of an Issuing Financial Institution**: In the event of insolvency or bankruptcy of the trustee or issuing institution of the financial mechanism; the suspension or revocation of the authority of the trustee institution to act as trustee; or the issuing institution's losing its authority to issue such an instrument: The Permittee must notify the Director within 10 business days of the Permittee receiving notice of such event. A Permittee who obtains a letter of credit, surety bond, or insurance policy will be deemed to be without the required FR or liability coverage in the event of bankruptcy, insolvency, or a suspension or revocation of the license or charter of the issuing institution. The Permittee must establish other financial responsibility or liability coverage acceptable to the Director, within 60 calendar days after such an event.
3. **Changes in Coverage**: Whenever a cost estimate increases to an amount greater than the face amount of a controlling financial instrument, the Permittee, within 60 days after the increase, must either cause the face amount to be increased to an amount at least equal to the current cost estimate and submit evidence of such increase to the Director, or obtain other qualifying financial responsibility instruments to cover the increase. Inability to provide full financial coverage will result in termination of the permit. Whenever a current cost estimate decreases to an amount less than the face amount of a controlling financial instrument, the face amount of the financial assurance

instrument may be reduced to the amount of the current cost estimate only after the Permittee has received written approval from the Director. (40 CFR 146.85(c)(4)).

I. WELL CONSTRUCTION REQUIREMENTS

The requirements listed in this section outline the approved and required construction standards per 40 CFR 146.86. The full permit application includes a more detailed EPA-approved design and specifications for the injection well, injection zone monitoring wells, confining zone monitoring wells, and groundwater monitoring wells that are the subject of this permit. Additionally, the approved stimulation program for the well is in Attachment 5. Changes to the approved construction plan must be approved by the Director through permit modification prior to operation.

1. **Injection Well Construction:** The well must be constructed in accordance with 40 CFR 146.86. The design and construction must allow continuous monitoring of the annulus between the long string casing and the injection tubing and accommodate testing devices and workover tools. Equipment must be calibrated and maintained per the permit's Quality Assurance and Surveillance Plan. During construction, the Permittee may make changes to the design of the injection well consistent with the conditions of this Permit. If the Permittee intends to make any changes to the design of the well, notification must first be made to EPA and the construction changes must be provided for review and approval by the Director before installation. Once the construction of the well is completed, and prior to authorization to inject, the Permittee must submit the final, as-built construction specifications and diagrams within 30 days for review and approval by the Director. Any deviations from the proposed design and as-built construction of the well must be noted and approved by the Director in advance. If the changes in well design are significant as determined by the Director, the Director may require this Permit to be modified.
2. **Siting:** The permittee has demonstrated to the satisfaction of the Director that the well is in an area with suitable geology in accordance with the requirements at 40 CFR 146.83.
3. **Casing and Cementing:** The well must be cased and cemented per 40 CFR 146.82 and 146.86. Casing, cement, or other materials used in the construction of the well must have sufficient structural strength for the life of the geologic sequestration project. All well materials must be compatible with all fluids with which the materials may be expected to come into contact and must meet or exceed standards developed for such materials by the American Petroleum Institute, ASTM International, or comparable standards acceptable to the Director. The well must be cased and cemented to prevent the movement of fluids into or between USDWs for the expected duration of the geologic sequestration project in accordance with 40 CFR 146.86. The casing and cement used in the construction of this well are shown in Attachment 4 of this permit and in the application for this permit. Any change must be submitted in an electronic format for approval by the Director before installation.

4. **Injection Tubing and Packer:** The tubing and packer design must meet the requirements of 40 CFR 146.86(c). Tubing and packer materials used in the construction of the well must be compatible with fluids with which the materials may be expected to come into contact and must meet or exceed standards developed for such materials by the American Petroleum Institute, ASTM International, or comparable standards acceptable to the Director. Injection must only take place through the tubing, with a packer set in the long string casing within or below the nearest cemented and impermeable confining system no more than 100 feet above the injection zone. The tubing and packer used in the well are represented in the engineering drawings contained in Attachment 4 of this permit. Any change must be submitted in an electronic format and approved by the Director before installation.

5. **Sampling and Monitoring Devices:** The Permittee must install and maintain in good condition all devices required to measure, monitor, and record the data and parameters referred to in Attachments 1 and 6 of this Permit per their Quality Assurance and Surveillance Plan. The Permittee must ensure that the devices installed, and methods used are sufficient to represent the activity being measured, monitored, or recorded. For required continuous monitoring, the Permittee must use devices capable of accurately monitoring the required activity. Calculated flow data or periodic monitoring are not acceptable for required continuous monitoring except as a backup system if the primary continuous monitoring devices malfunction or become inoperable. The Permittee must notify EPA of such occurrences within 24 hours, and continuous monitoring devices must be repaired or replaced as soon as practicable. If this length of time is extensive, in the opinion of the Director, injection activities must cease until regular monitoring is restored. The Permittee must ensure the well's construction and near-wellhead design are appropriate for collecting samples and fulfilling all monitoring requirements of this Permit. The Permittee must ensure adequate well diameter to accommodate appropriate tools for well development, aquifer testing equipment, and water quality sampling devices. The Permittee must ensure all gauges used for monitoring and testing are appropriately calibrated and maintained.

6. **Monitoring Well Construction:** 40 CFR 146.84 and 146.90(g) require monitoring of the carbon dioxide plume and pressure front of the confining and injection zones and 40 CFR 146.90(d) requires monitoring of groundwater located above the injection zone. These sections are incorporated by reference into this permit. Groundwater, confining zone, and injection zone monitoring wells must be constructed as depicted in the application referenced in Attachment 6 of this Permit using materials compatible with the injected fluids. All monitoring wells must be constructed in a manner that provides representative samples that can be analyzed for the monitoring parameters required by this Permit. Once the construction of the monitoring wells has been completed, the as-built construction diagrams must be included in the Pre-Injection Testing Report to be submitted to the Director.

J. PRE-INJECTION TESTING

Testing is required during the construction of the well per 40 CFR 146.87. This testing is required to verify the geology of the well site to ensure compliance with the well construction requirements per 40 CFR 146.86 and to test the viability of the well to meet the stipulated operational requirements. All testing must be conducted in accordance with 40 CFR 146.87 and using the procedures in Attachment 6 of this Permit.

1. Prior to receiving authorization to commence injection, the Permittee must perform all pre-injection logging, sampling, testing, and coring specified in 40 CFR 146.87 and submit to the Director for approval a descriptive report that includes a detailed interpretation of the results of such logging, sampling, testing, and coring. At a minimum, this testing must include:
 - a. Logs, surveys, and tests to determine or verify the depth, thickness, porosity, permeability, lithology, and formation fluid salinity in all relevant geologic formations. These tests must include:
 - i. Deviation checks that meet the requirements of 40 CFR 146.87(a)(1);
 - ii. Logs and tests before and upon installation of the surface casing that meet the requirements of 40 CFR 146.87(a)(2);
 - iii. Logs and tests before and upon installation of the long-string casing that meet the requirements of 40 CFR 146.87(a)(3);
 - iv. Tests to demonstrate internal and external mechanical integrity that meet the requirements of 40 CFR 146.87(a)(4); these tests may include a pressure test with liquid or gas, a casing inspection log, and an approved tracer survey such as an oxygen activation log or a temperature or noise log; and
 - v. Any alternative methods that are required by and/or approved by the Director pursuant to 40 CFR 146.87(a)(5).
 - b. Whole cores or sidewall cores of the injection zone confining system, and any other formations as required by the Director, and formation fluid samples from the injection zone that meet the requirements of 40 CFR 146.87(b).
 - c. Documentation of the measured fluid temperature, pH, conductivity, reservoir pressure, and static fluid level of the injection zone(s) that meet the requirements of 40 CFR 146.87(c).
 - d. Tests to determine well-specific data regarding the injection and confining zones.

These tests must determine fracture pressure, the physical and chemical characteristics of the injection and confining zones, and the formation fluids in the injection zone that meet the requirements of 40 CFR 146.87(b)-(d).

- e. Tests to verify hydrogeologic characteristics of the injection zone that meet the requirements of 40 CFR 146.87(e), including:
 - i. A pressure fall-off test; and
 - ii. A pump test or injectivity test.
- 2. The Permittee must submit to the Director for approval in electronic format a schedule for pre-operational testing activities 30 days before conducting the first test and submit any changes to the schedule 30 days before the next scheduled test. The Permittee must also provide the Director with the opportunity to witness all logging, sampling, testing, and coring required under this Section.

K. INJECTION WELL OPERATION

1. **Outermost Casing Injection Prohibition:** Injection between the outermost casing protecting USDWs and the well bore is prohibited.
2. **Injection Pressure Limitation:** Except during stimulation or at other specific times as approved by the Director, the Permittee must ensure that injection pressure does not exceed 90 percent of the fracture pressure of the injection zone(s) and does not initiate new fractures or propagate existing fractures in the injection zone(s). Under no circumstance shall injection pressure initiate fractures or propagate existing fractures in the confining zone or cause the movement of injection or formation fluids into a USDW. The injection pressure limit is listed in Attachment 1 of this Permit.
3. **Stimulation Program:** If injection rates decline below expected values at any time during the project life, the Permittee shall investigate the cause to determine whether stimulation may be required. The Permittee must obtain prior approval from the Director to conduct stimulation activities and carry out the Stimulation Plan in accordance with the proposed stimulation program in Attachment 5.
4. **Additional Injection Limitations:** No injection fluid other than supercritical CO₂ may be injected except fluids used for stimulation, rework, and well tests as approved by the Director. Injection must occur within the injection tubing.
5. **Annulus Fluid:** The Permittee must fill the annulus between the tubing and the long string casing with a non-corrosive fluid approved by the Director.
6. **Annulus/Tubing Pressure Differential:** Except during workovers or times of annulus maintenance, the Permittee must maintain pressure on the annulus that exceeds the operating injection pressure as specified in Attachment 1 of this Permit, unless the Director determines that such requirement might harm the integrity of the well or endanger USDWs.
7. **Maintenance of Mechanical Integrity:** Other than during periods of well workover (maintenance) approved by the Director in which the sealed tubing-casing annulus is disassembled for maintenance or corrective procedures, the owner or Permittee must always maintain the injection well's mechanical integrity.
8. **Continuous Recording Devices, Automatic Alarms, and Automatic Shut-Off Systems:**
The Permittee must:
 - a. Install and use continuous recording devices to monitor the injection pressure; the rate, volume and/or mass, and temperature of the carbon dioxide stream; and the

pressure on the annulus between the tubing and the long string casing and annulus fluid volume;

- b. Install, continuously operate, and maintain an automatic alarm and automatic shut-off system or, at the discretion of the Director, down-hole shut-off systems, or other mechanical devices that provide equivalent protection; and
- c. Successfully demonstrate the functionality of the alarm system and shut-off system prior to the Director authorizing injection, and at a minimum of once every twelfth month or as recommended by the equipment manufacturer, whichever is sooner, after the last approved demonstration.

Testing under this Section must involve subjecting the system to simulated failure conditions and must be witnessed by the Director or their representative unless the Director authorizes an unwitnessed test in advance. The Permittee must provide notice in an electronic format 30 days prior to running the test and must provide the Director or their representative the opportunity to attend. The test must be documented using either a mechanical or digital device that records the value of the parameter of interest or by a service company job record. A final report, including any additional interpretation necessary for the evaluation of the testing, must be submitted in an electronic format within the time period specified in Section N of this Permit.

9. **Precautions to Prevent Well Blowouts:** Except at specific times as approved by the Director, the Permittee must maintain on the well a pressure that will prevent the return of the injection fluid to the surface. The well bore must be filled with a fluid of sufficient specific gravity during workovers to maintain a positive (downward) pressure gradient, and/or a plug shall be installed that can resist the pressure differential. A blowout preventer must be installed and kept in proper operational condition whenever the wellhead is removed to work on the well. The Permittee must follow procedures such as those below to ensure that a backflow or blowout does not occur:
 - a. Limit the temperature and/or corrosivity of the injectate; and
 - b. Develop procedures necessary to ensure that pressure imbalances do not occur.
10. **Circumstances Under Which Injection Must Cease:** Injection must cease when any of the following circumstances arise:
 - a. Failure of the well to pass a mechanical integrity test;
 - b. A loss of mechanical integrity during operation;

- c. The automatic alarm or automatic shut-off system is triggered;
- d. A significant unexpected change in the annulus or injection pressure occurs;
- e. The Director determines that the well lacks mechanical integrity;
- f. Movement of injection or formation fluids into a USDW is detected;
- g. Conditions described in Section Q, Seismic Event Response of this Permit, occur;
- h. The Director determines the site is no longer suitable for injection based on new information about the site geology; or
- i. The Director determines that the Permittee cannot maintain compliance with any condition of this Permit or regulatory requirement.

In all instances where injection ceases, it must stop immediately, and the Permittee must get approval from the Director to resume injection.

If an automatic shutdown (i.e., down-hole or at the surface) is triggered, the Permittee must immediately investigate and identify the cause of the shutdown as expeditiously as possible. If, upon investigation, the well appears to lack mechanical integrity, or if the required monitoring of data from continuous recording devices or automatic shutoff systems indicates that the well may lack mechanical integrity, the Permittee must take the actions listed below in Section L of this Permit.

L. MECHANICAL INTEGRITY

The Permittee must ensure that the injection well and all other wells covered by this permit have both internal (no significant leaks in the casing, tubing, and packer) and external (no significant fluid movement outside of the injection zone) mechanical integrity for the entire operational life of the well. The required tests and test procedures for mechanical integrity are referred to in Attachment 6 of this Permit.

1. **Standards:** Other than during periods of well workover (repair or maintenance) approved by the Director in which the sealed tubing-casing annulus is disassembled for maintenance or corrective procedures, the injection well must have and maintain mechanical integrity consistent with 40 CFR 146.89. The Permittee must demonstrate mechanical integrity using the approved tests and test procedures in Attachment 6. The Permittee must also conduct any additional testing as the Director may require to make this determination. The determination of whether the injection well has mechanical integrity is at the discretion of the Director.
2. **Mechanical Integrity Demonstration Requirements and Schedule:**
 - a. The Permittee must demonstrate internal and external mechanical integrity as follows.
 - i. After well construction is completed using tests listed in Section J.1.(a)(iv) of this Permit.
 - ii. Continuous monitoring of pressure on the annulus between the tubing and the long string casing to demonstrate internal mechanical integrity.
 - iii. Annually for external mechanical integrity using a method listed in 40 CFR 146.89(c).
 - iv. After any loss or suspected loss of mechanical integrity.
 - v. Demonstrate internal mechanical integrity annually and after any well alteration, repair, or workover that may compromise the internal mechanical integrity of the well, including well stimulation.
 - vi. Demonstrate external mechanical integrity prior to plugging the well pursuant to 40 CFR 146.92(a) and as listed in Attachment 7 of this Permit.
 - vii. After a seismic event as Section Q of this Permit outlines.
 - viii. Any time upon written request from the Director.
 - b. The Permittee must obtain written authorization from the Director prior to commencing/resuming injection in any of the circumstances listed in Section R.

3. **Monitoring Wells:** The Testing and Monitoring Plan referenced in Attachment 6 of this Permit outlines required mechanical integrity tests and procedures for the confining zone and injection zone monitoring wells. Testing and demonstration of monitoring wells must be conducted annually. The director can consider other tests and/or procedures not listed in this plan for approval.
4. **Alternative Mechanical Integrity Tests and Procedures:** The Permittee must submit any proposed alternative tests and/or procedures not listed in this permit to EPA for approval prior to using them to demonstrate mechanical integrity.
5. **EPA Witnessing of Mechanical Integrity Tests:** The Permittee must provide notice in an electronic format 30 days prior to running the test and must provide the Director or their representative the opportunity to attend. To conduct testing without an EPA witness, the Permittee must adhere to the following procedures:
 - a. Submit prior notice in an electronic format to the Director within 30 days of the test, including the information that no EPA representative is available, and receive permission from EPA to proceed;
 - b. Perform the test in accordance with the Testing and Monitoring Plan found in Attachment 6 of this Permit and document the test using either a mechanical or digital device that records the value of the parameter of interest; and
 - c. Within 30 days of the test, submit a final report, including any additional interpretation necessary for evaluating the testing, a test record(s), and gauge certification(s), in electronic format to the Director for approval.
6. **Gauge and Meter Calibration:** Prior to testing, the Permittee must ensure proper calibration of all gauges used in mechanical integrity demonstrations and other monitoring required by this Permit. All equipment must be calibrated in the manner and frequency recommended by the manufacturer and within at least one year prior to each required test. The date of the most recent calibration must be noted on or near the gauge or meter. A copy of the calibration certificate(s) must be submitted to the Director in electronic format with the final report. All recordings must record to an accuracy of no more than 0.5 percent of full scale for mechanical gauges. Pressure gauge resolution must be no greater than five psi. Additionally, specific mechanical integrity tests and other testing may require greater accuracy and must be identified in the procedure submitted to the Director prior to the test.
7. **Notification Prior to Testing and Reporting:**
 - a. The Permittee must notify the Director in an electronic format of intent to

demonstrate mechanical integrity at least 30 days prior to such demonstration. At the discretion of the Director, a shorter time period may be allowed.

- b. The Permittee must notify the Director of any loss or suspected loss of mechanical integrity following the procedures in Section N of this Permit.
 - c. The Permittee must report in an electronic format the results of a mechanical integrity demonstration as soon as possible but no later than 30 days after the demonstration is complete. Reports of mechanical integrity demonstrations, which include logs, must include an interpretation of results by a knowledgeable log analyst.
8. **Loss of Mechanical Integrity:** If the Permittee or the Director finds that the well fails to demonstrate mechanical integrity during a test, or fails to maintain mechanical integrity during operation, or that a loss of mechanical integrity as defined by 40 CFR 146.89(a)(1) or (2) is suspected during operation (such as a significant unexpected change in the annulus or injection pressure), the Permittee must:
- a. Cease injection immediately;
 - b. Take all steps reasonably necessary to determine whether there may have been a release of the injected carbon dioxide stream or formation fluids into any unauthorized zone. If there is evidence of potential USDW endangerment, the Emergency and Remedial Response Plan must be implemented (Attachment 9 of this Permit);
 - c. Within 24 hours of the event, notify the Director of the circumstances surrounding the event;
 - d. Notify the Director in an electronic format when injection can be expected to resume and submit a projected plan for reestablishing mechanical integrity or plugging the well.
 - e. Follow any other applicable reporting requirements as directed in Section N of this Permit;
 - f. Restore and demonstrate mechanical integrity to the satisfaction of the Director and receive written approval from the Director prior to resuming injection; and
 - g. Either plug or repair and retest the well within 30 days of losing mechanical integrity if the well loses mechanical integrity prior to the next scheduled test date.

M. TESTING AND MONITORING

The required specific measurement and reporting frequencies for testing and monitoring activities are listed in Attachment 6. Sampling parameters, sampling handling and custody, quality control, and quality assurance will be performed as described in the Quality Assurance and Surveillance Plan procedures, which are partly documented in the tables below.

1. **Testing and Monitoring Plan:** The Permittee must maintain and comply with the approved Testing and Monitoring Plan referenced in Attachment 6 of this Permit and with the requirements within 40 CFR 144.51(j), 146.88(e), and 146.90, and any modifications required by the Director after the effective date of this Permit. Samples and measurements taken for the purpose of monitoring must be representative of the monitored activity. Procedures for all testing and monitoring under this Permit must be submitted to the Director in an electronic format for approval at least 30 days prior to the test, if they plan to deviate from the procedures outlined in the Testing and Monitoring Plan referenced in Attachment 6 of this Permit and detailed in the Quality Assurance and Surveillance Plan. The final report must be delivered to the Director 30 days after testing. When the test report is submitted, a full explanation must be provided as to why any approved procedures were not followed. If the approved procedures were not followed, EPA may take appropriate action, including but not limited to requiring the Permittee to re-run the test.

The Permittee must update the Testing and Monitoring Plan as required by 40 CFR 146.90(j) to incorporate monitoring and operational data and in response to AoR reevaluations required under Section G of this Permit or demonstrate to the Director that no update is needed. The amended Testing and Monitoring Plan or demonstration must be submitted to the Director in an electronic format within one year of an AoR reevaluation following any significant changes to the facility, such as the addition of monitoring wells or newly permitted injection wells within the AoR or when required by the Director.

Following each update of the Testing and Monitoring Plan or a demonstration that no update is needed, the Permittee must submit the resultant information in an electronic format to the Director for review and approval of the results. Once approved by the Director, the revised Testing and Monitoring Plan will become an enforceable condition of this Permit.

2. **Carbon Dioxide Stream Analysis:** The Permittee must analyze the carbon dioxide stream with sufficient frequency to yield data representative of its chemical and physical

characteristics, as described in the approved Testing and Monitoring Plan, and to meet the requirements of 40 CFR 146.90(a).

Summary of CO2 Injectate Stream Monitoring

Method	Pre-Injection	Injection	Post-Injection
Online gas chromatography / gas analyzer of supercritical CO2 in the flowline upstream of the injector wells*	NA	Continuously	NA
Laboratory gas chromatography of samples obtained from a sample port upstream of the injector wells **	NA	Quarterly; or event-driven if the DAC process materially changes	NA
Laboratory isotopic analysis of injectate samples	Prior to injection	Event-driven if the DAC process materially changes	NA

*** Summary of specifications for on-line gas chromatograph**

Parameters	Analytical Methods
Analysis time	Approximately 5 minutes
Repeatability	±0.25% of heating value over temperature range
Temperature Range	-4°F to 140°F
Calibration	Besides automated calibration feature that is available to the GC, the manufacture shall recommend appropriate inspection, maintenance, and calibration frequency per the specific application.
Range	Pipeline quality gas with less than 100 ppm H2S
Calculations	GPA 2172-96 (Z by AGA 8 or single viral summation) and 2145-03, ISO 6976-95; meets ISO 12213-2 by AGA 8 detail

Components measured	N2 through CO, C1, CO2, C2, C3, IC4, NC4, NeoC5, IC5, NC5, C6+, H2S
---------------------	---

**** CO2 Injectate Stream Specifications**

Parameters	Analytical Methods ¹	Detection Limit / Range ²	Typical Precision ²	QC Requirements
CO2 content	GPA 2177-20 ³	>95 mol%	GPA 2177-20	GPA 2177-20
Water	GPA 2177-20	<30 lbm/MMscf	GPA 2177-20	GPA 2177-20
Nitrogen	GPA 2177-20	<4 mol%	GPA 2177-20	GPA 2177-20
Sulphur	GPA 2177-20	<35 ppm by weight	GPA 2177-20	GPA 2177-20
Oxygen	GPA 2177-20	<5 mol%	GPA 2177-20	GPA 2177-20
Glycol	GPA 2177-20	<0.3 gal/MMscf	GPA 2177-20	GPA 2177-20
Carbon Monoxide	GPA 2177-20	<4,250 ppm by weight	GPA 2177-20	GPA 2177-20
NOx	GPA 2177-20	<6 ppm by weight	GPA 2177-20	GPA 2177-20
SOx	GPA 2177-20	<1 ppm by weight	GPA 2177-20	GPA 2177-20
Particulates (CaCO3)	GPA 2177-20	<1 ppm by weight	GPA 2177-20	GPA 2177-20
Argon	GPA 2177-20	<1 mol%	GPA 2177-20	GPA 2177-20
Surface pressure	GPA 2177-20	>1,600 psig	GPA 2177-20	GPA 2177-20
Surface temperature	GPA 2177-20	>65°F and <120°F	GPA 2177-20	GPA 2177-20
Isotopes	Isotope ratio mass spectrometry and accelerator mass spectrometry	$\delta^{13}\text{C}$ and ^{14}C of CO2	$\pm 0.15 - 0.03\%$	10% duplicates, 4 samples per batch

¹An equivalent method may be employed with the prior approval of the UIC Program Director.

²Detection limits and precision (laboratory control limits) are typical for these analytical methods.

³GPA Midstream Standard licensed to OLCV

3. **Continuous Monitoring:** The Permittee must install and use continuous recording devices to monitor: the injection pressure (at the surface and at injection interval), injection flow rate, injection mass, pressure on the annulus between the tubing and the long string of casing, annulus fluid level, and temperature (at the surface and at injection interval). This monitoring must be performed as described in the Testing and Monitoring Plan to meet the requirements of 40 CFR 146.90(b). The Permittee must maintain for EPA's inspection at the facility an appropriately scaled, continuous record of all monitoring results as well as original files of any digitally recorded information pertaining to these operations.

Summary of Continuous Monitoring

Objective	Method	Minimum sampling frequency	Minimum recording frequency
Injection pressure and temperature at surface	Surface gauges installed on injection line near wellhead*	One second	30 seconds
Injection rate and volume	Mass flow meter on injection line near wellhead	One minute	One hour
Injection pressure and temperature downhole	Downhole tubing-deployed gauge above packer ported to tubing above packer	10 seconds	30 seconds
	DTS fiber**	10 minutes	30 minutes
Pressure on the annulus between the tubing and long string casing	Downhole tubing-deployed gauges ported to annulus above packer	10 seconds	30 seconds
Annular pressure at surface	Pressure gauge installed in wellhead	One second	30 seconds
Annulus volume	Continuous pressure monitoring between tubing and production casing, and continuous monitoring of	10 seconds pressure gauge; fluid level as needed	30 seconds on pressure gauge, fluid level as needed

	pressure at surface to confirm absence of leakage. Direct fluid level measurements may also be obtained, as triggered by pressure data.		
--	---	--	--

*** Summary of measurement parameters for field gauges**

Parameters	Analytical Methods	Detection Limit / Range	Typical Precision	QC Requirements
Surface injection line pressure gauge	Piezoresistive pressure sensor feeds data back to PLC / SCADA ¹	2 psi / 0 – 3,000 psi	+/- 0.065% of full span	Annual or per manufacture recommendation, whichever is more frequent
Surface injection line temperature gauge	Resistance temperature detector or thermocouple ²	250° F	±1° F	Annual or per manufacture recommendation, whichever is more frequent
Downhole temperature and pressure gauges	Permanent gauge ³	8,000 psi, 250° F	±3 psi, ± 0.27° F	Annual or per manufacture recommendation, whichever is more frequent
Wellhead tubing pressure	Piezoresistive pressure sensor feeds data back to PLC / SCADA ⁴	2 psi / 0 – 3,000 psi	+/- 0.065% of full span	Annual or per manufacture recommendation, whichever is more frequent
Wellhead annulus pressure	Piezoresistive pressure sensor feeds data back to PLC / SCADA ⁵	2 psi / 0 – 3,000 psi	+/- 0.065% of full span	Annual or per manufacture recommendation, whichever is more

				frequent
CO2 injection mass flow rate	Coriolis or Orifice meter feeds data back to PLC / SCADA ⁶	1.5 metric ton/day/0-1500 metric ton/day	+/- 0.25% of full span	Quarterly or per manufacture recommendation, whichever is more frequent

**** Technical specifications for DTS fiber**

Parameter	Value
Spatial resolution	1 m (3.2 ft) across entire measurement range
Sampling resolution	To 0.5 m (1.6 ft) across entire measurement range
Temperature resolution	<0.1°C (0.18°F)
Accuracy	±0.5°C (±0.9°F)
Measurement range	Up to 12 km
Measurement temperature range	-250°C to 400°C
Measurement times	10 sec to 24 hr
Dynamic range	30 dB
Operating environment	-10°C to 60°C, humidity 0% to 95% non-condensing
Tensile strength	2,372 lbf
Yield strength	2,018 lbf
Strain at yield	0.31%

Hydrostatic Pressure	23,872 psi
Burst Pressure	28,050 psi
Working Pressure	20,526 psi
Static Bend Radius	3 in.

¹Surface pressure gauge specifications

Parameter	Value
Calibrated working pressure range	0 to 3,000 psi
Initial pressure accuracy	± 0.065%
Pressure resolution	1.95 psi
Pressure drift stability	0.05% annually

²Temperature Gauge Specifications: Injection tubing temperature

Parameter	Value
Calibrated working temperature range	0 to 250 °F
Initial temperature accuracy	±0.12 %
Temperature resolution	0.3 °F
Temperature drift stability	±0.54 deg. F following 1000 hours at max. specified temperature

³Downhole pressure and temperature gauge specifications

Parameter	Value
Calibrated working pressure range	Atmospheric to 10,000 psi
Initial pressure accuracy	<± 2 psi over full scale

Pressure resolution	0.005 psi at 1 sec sample rate
Pressure drift stability	<± 1 psi per year over full scale
Calibrated working temperature range	77 – 266 °F
Initial temperature accuracy	<± 0.9 °F at 1 sec sample rate
Temperature resolution	0.009 °F at 1 sec sample rate
Temperature drift stability	<± 0.9 °F at 1 sec sample rate
Max temperature	302 °F

⁴Pressure gauge specifications: Injection tubing pressure

Parameter	Value
Calibrated working pressure range	0 to 3,000 psi
Initial pressure accuracy	± 0.065%
Pressure resolution	2 psi
Pressure drift stability	0.05% annually

⁵Pressure gauge specifications: Annulus pressure

Parameter	Value
Calibrated working pressure range	0 to 3,000 psi
Initial pressure accuracy	± 0.065%
Pressure resolution	2 psi
Pressure drift stability	0.05% annually

⁶CO₂ mass flow rate gauge specifications

Parameter	Value
Calibrated working flow rate range	0 – 1500 metric ton / day
Initial flow rate accuracy	± 0.1 %
Mass flow rate resolution	1.5 metric ton / day

4. **Corrosion Monitoring**: The Permittee must perform quarterly corrosion monitoring of the well construction materials for loss of mass, thickness, cracking, pitting, and other signs of corrosion using the procedures described in the Testing and Monitoring Plan and in accordance with 40 CFR 146.90(c). This ensures that the well components meet the minimum standards for material strength and performance set forth in 40 CFR 146.86(b).

Summary of Corrosion Monitoring

Objective	Method	Pre-Injection	Injection	Post-Injection
Identify material corrosion in flowline and wellbore	Corrosion coupons*	N/A	Quarterly	N/A
	Casing inspection log	Caliper cased hole log prior to injection operations	During planned well maintenance	N/A
Identify loss of mechanical integrity that could lead to corrosion	DTS	Prior to injection	Continuously	N/A
Surface monitoring and leak detection	Visual inspection and portable monitors	Prior to injection	Weekly	N/A
	OGI camera**	Prior to injection	Quarterly	N/A
	CO ₂ surface sensors	Prior to injection	Continuously	N/A

*** Summary of Analytical Parameters for Corrosion Coupons**

Parameters	Analytical Methods ¹	Detection Limit / Range ²	Typical Precision ²	QC Requirements
Mass	NACE SP0775-2018-SC	0.05 mg	2%	N/A
Thickness	NACE SP0775-2018-SC	0.01 mm	± 0.05 mm	N/A

****Summary of Measurement Parameters for Surface Optical Cameras**

Parameter	Value
Sensitivity to detect CO ₂	<1.1 ppm ($\Delta T = 10^{\circ}C$, Distance = 1 m)
Thermal sensitivity	15 mK at 30°C (86°F)
Spectral range	4.2 μm
Operating Temperature Range	-20°C to 50°C (-4°F to 122°F)

- Groundwater Monitoring Above the Confining Zone:** The Permittee shall monitor groundwater quality and geochemical changes above the confining zone that may be a result of carbon dioxide movement through the confining zone and additional identified geologic units. All monitoring conducted must be performed for the parameters identified in the approved Testing and Monitoring Plan at the locations and depths, and at frequencies described in the Testing and Monitoring Plan to meet the requirements of 40 CFR 146.90(d).

Summary of Groundwater Above Confining Zone Monitoring

Objective	Method	Frequency pre-injection	Frequency during injection	Frequency post-injection
Fluid and dissolved gas geochemistry in the lowermost USDW*	Fluid and dissolved gas sampling and analysis**	During construction and quarterly during baseline	Quarterly geochemical sampling in years 1-3 and annually starting in year 4; and event-driven,	Annually for first 10 years; and event-driven, triggered by P/T or soil gas chemistry

			triggered by P/T in SLR wells or soil gas chemistry	
--	--	--	---	--

*** Stabilization criteria of water quality parameters during USDW-level well purging**

Field Parameter	Stabilization Criteria
pH	±0.2 units
Temperature	±10% of reading
Specific conductance	±3% of reading
Oxidation-Reduction Potential (ORP)	±10 mV of reading
Dissolved oxygen	±10% of reading or 0.3 mg/L whichever is greater
Turbidity	±10% of reading or below 10 NTU

Summary of analytical parameters for fluid and dissolved gas samples in the Injection Zone (Lower San Andres), the first permeable zone above the confining zone (Yates) and lowermost USDW (Dockum aquifer)

Laboratory Analyte	Analytical Methods	Detection Limit / Range	Typical Precision	QC Requirements*
Groundwater analysis				
Total Metals/Metalloids: Al, As, Ba, B, Cd, Ca, Co, Cu, Cr, Fe, Pb, Li, Mg, Mn, Mo, Ni, P, K, Sb, Se, Si, Na, Sr, Ti, V, and Zn	EPA Method 6010D	Detection limits range from 0.005 - 0.5 mg/L	± 20%	Frequent calibration, method blank, lab control samples, matrix spikes and sample duplicate.
Dissolved Metals/Metalloids: Al, As, Ba, B, Cd, Ca, Co, Cu, Cr, Fe, Pb, Li, Mg, Mn, Mo, Ni, P, K, Sb, Se, Si, Na, Sr, Ti, V, and Zn	EPA Method 6010D	Detection limits range from 0.005 - 0.5 mg/L	± 20%	Frequent calibration, method blank, lab control samples, matrix spikes and sample duplicate.
Total	EPA Method	0.001 mg/L	± 20%	Frequent calibration, method blank, lab control samples,

Metals/Metalloids: U	6020B			matrix spikes and sample duplicate.
Dissolved Metals/Metalloids : U	EPA Method 6020B	0.001 mg/L	± 20%	Frequent calibration, method blank, lab control samples, matrix spikes and sample duplicate.
Total Metals/Metalloids: Hg	EPA Method 7470A	0.0002 mg/L	± 20%	Frequent calibration, method blank, lab control samples, matrix spikes and sample duplicate.
Dissolved Metals/Metalloids: Hg	EPA Method 7470A	0.0002 mg/L	± 20%	Frequent calibration, method blank, lab control samples, matrix spikes and sample duplicate.
Anions: Br, Cl, F, NO ₂ , NO ₃ and SO ₄	EPA Method 300.0	Detection limits range from 0.1 - 0.5 mg/L	± 10% ± 20% (NO ₃)	Frequent calibration, method blank, lab control samples, matrix spikes and sample duplicate.
Anions: PO ₄ ³⁻	EPA Method 365.1	0.0613 mg/L	N/A	Frequent calibration, method blank, lab control samples, matrix spikes and sample duplicate.
Cation-Anion balance	SM 1030E	N/A	N/A	Frequent calibration, method blank, lab control samples, matrix spikes and sample duplicate.
Conductivity/Specific Conductance	SM 2510B	10 umhos/cm @ 25C	N/A	Frequent calibration, method blank, lab control samples, matrix spikes and sample duplicate.
Total, Bicarbonate, Carbonate, & Hydroxide Alkalinity	SM 2320B	4 mg/L	± 15%	Frequent calibration, method blank, lab control samples, matrix spikes and sample duplicate.
pH	SM 4500 H+	0.1 S.U.	± 0.1 S.U.	Frequent calibration and sample duplicate.
Total dissolved solids (TDS)	SM 2540C	5 mg/L	± 20%	Frequent calibration, method blank, lab control samples, matrix spikes and sample duplicate.
Water density (lab)	SM 2710F	N/A	N/A	Frequent calibration and sample duplicate.
Dissolved Inorganic Carbon (DIC)	SM 5310B	0.5 mg/L	± 20%	Frequent calibration, method blank, lab control samples, matrix spikes and sample duplicate.

Water Isotopic Analysis				
$^{228}\text{Ra}/^{226}\text{Ra}^\dagger$	EPA Method 901.1	50 pCi/L (RL)	$\pm 25\%$	Frequent calibration, method blank, lab control samples, matrix spikes and sample duplicate.
$^{87}\text{Sr}/^{86}\text{Sr}^\dagger$	ICP-MS - subcontracted to the University of Illinois	~ 4 ppb Sr required for accurate isotopic results	± 0.00005 ppm	Frequent calibration, method blank, lab control samples, matrix spikes and sample duplicate. At least one secondary standard is measured with each sample batch and approx. 10% of samples submitted are prepared and measured a second time.
$^{87}\text{Sr}/^{86}\text{Sr}^\dagger$	TIMS - subcontracted to the University of AZ	approximately 40 ppm	± 0.00002 ppm	SRM 987 Sr standard within the long-term precision (external precision) of ± 0.00002 accepted value of 0.71025
$\delta^{18}\text{O}$ and $\delta^2\text{H}$ of $\text{H}_2\text{O}^\dagger$	Analyzed via CRDS	N/A	$\delta^{18}\text{O}$: 0.10 per mil, $\delta^2\text{H}$: 2.0 per mil	20% of all analyses are either check/reference standards or duplicate analyses.
$\delta^{13}\text{C}$ of DIC	Gas Bench/CF - IRMS	Depends on available sample volume, minimum of 50mg/L required	0.20 per mil	20% of all analyses are either check/reference standards or duplicate analyses.
^{14}C of DIC †	AMS - subcontracted to Beta Analytic	Depends on available sample volume	$\pm 1 - 2$ pMC	Daily monitoring of instrumentation and chemical purity in addition to extensive computer and human cross-checks.
Dissolved Gas Samples and Isotopic Analyses				
Dissolved Gas: N_2 , CO_2 , CO , O_2 , Ar, H_2 , He, CH_4 , C_2H_6 , C_3H_8 , i- C_4H_{10} , n- C_4H_{10} , i-	In-house Lab SOP, similar to	Lowest quantifiable limits 1-100 ppm, varies by	C1-C4: $\pm 5\%$ C5-C6+: \pm	20% of all analyses are check/reference

C5H12, n-C5H12 and C6+†	RSK-175	component	10%	standards.
Dissolved CO2	SM 4500 CO2 D	1.25 mg/L	Not applicable	Frequent calibration, method blank, lab control samples, matrix spikes and sample duplicate.
¹⁴ C of CH4	High precision (offline) analysis via Dual Inlet IRMS	0.44pMC	± 1-2 pMC	Frequent calibration, method blank, lab control samples, matrix spikes and sample duplicate. At least one secondary standard is measured with each sample batch and approx. 10% of samples submitted are prepared and measured a second time.
Dissolved Gas: H2S	SM 4500S F	1 mg/L	± 20%	Sample duplicates, method blanks and lab control samples.
δ ¹³ C of dissolved CO2, C1-C5, δ ² H of CH4†	High precision (offline) analysis via Dual Inlet IRMS	Varies by component	δ ¹³ C: 0.1 per mil δ ² H: 3.5 per mil	20% of all analyses are check/reference standards.
Composition and isotope noble gas: Ar, Kr, Xe, Ne, He, ³ He/ ⁴ He ratio, ²⁰ Ne/ ²² Ne ratio, ³⁶ Ar/ ⁴⁰ Ar ratio†	In-house Lab SOP, MS	TBD	± 1-5%	TBD
Field Parameters**				
pH (field)	Standard Method 2 4500-H+ B-2000	2 to 12 pH units	±0.2 pH unit	User calibration per manufacturer recommendation
Specific conductance (field)	EPA Method 120.1	0 to 200 mS/cm	±1% of reading	User calibration per manufacturer recommendation
Temperature (field)	Standard Method	-5 to 50 °C	±0.2 °C	Factory calibration

	2550 B-2000			
Oxidation-Reduction Potential (ORP) (field)	Standard Method 2580	-1999 to +1999 mV	±20 mV	User calibration per manufacturer recommendation
Dissolved oxygen (field)	ASTM Method D888-09 (C)	0 to 50 mg/L	0 to 20 mg/L (±0.1 mg/L or 1% of reading, whichever is greater) 20 – 50 mg/L (±8% of reading)	User calibration per manufacturer recommendation
Turbidity (field)	USEPA Method 180.1	0 – 1000 NTU	± 1% of reading or 0.01 NTU, whichever is greater	User calibration per manufacturer recommendation

† Analytical parameters to be included during the pre-injection phase, and only as needed during the injection and post-injection phases of the Project.

***Containers, preservation techniques and holding times for groundwater sample parameters collected in the Injection Zone, first permeable zone above the Upper Confining Zone and the lowermost USDW**

Parameters	Container and Volume	Preservation Technique	Max Holding Time
Geochemical Samples			
Total Metals/Metalloids: Al, As, Ba, B, Cd, Ca, Co, Cu, Cr, Fe, Pb, Li, Mg, Mn, Mo, Ni, P, K, Sb, Se, Si, Na, Sr, Ti, V, and Zn	250 mL/HDPE	Nitric acid, cooled to 4°C	180 days

Total Metals/Metalloids and Dissolved Metals/Metalloids: U	250 mL/HDPE	Nitric acid, cooled to 4°C	28 days
Total Metals/Metalloids and Dissolved Metals/ Metalloids: Hg	250 mL/HDPE	Nitric acid, cooled to 4°C	28 days
Dissolved Metals/Metalloids: Al, As, Ba, B, Cd, Ca, Co, Cu, Cr, Fe, Pb, Li, Mg, Mn, Mo, Ni, P, K, Sb, Se, Si, Na, Sr, Ti, V, and Zn	250 mL/HDPE	Filtered, nitric acid, cooled to 4°C	180 days
Anions: Br, Cl, F, NO ₂ , NO ₃ and SO ₄ Anions: PO ₄ ³⁻	250 mL/HDPE	Cooled to 4°C, Sulfuric Acid (Phosphorus)	28 days, 48 hours for NO ₃ only
Total, Bicarbonate, Carbonate, & Hydroxide Alkalinity	250 mL/HDPE	Cooled to 4°C	14 days
pH (lab)	250 mL/HDPE	Cooled to 4°C	Immediately
Total dissolved solids (TDS)	500 mL/HDPE	Cooled to 4°C	7 days
Water density (lab)	500 mL/Amber Glass	Cooled to 4°C	28 days
Dissolved Inorganic Carbon (DIC)	250 mL/Amber Glass	Filtered, cooled to 4°C	28 days
Cation-Anion balance	1 L/HDPE	Cooled to 4°C	N/A
Conductivity/Specific Conductance	250 mL/HDPE	Cooled to 4°C	28 days
Water Isotopic Analyses			
²²⁸ Ra/ ²²⁶ Ra	1 L/HDPE	Nitric acid, cooled to 4°C	180 days
⁸⁷ Sr/ ⁸⁶ Sr	30 mL	None	> 365 days
⁸⁷ Sr/ ⁸⁶ Sr	30mL	None	> 365 days
δ ¹⁸ O and δ ² H of H ₂ O	40 mL HDPE	None	> 365 days
δ ¹³ C of DIC	60 mL HDPE	Filtered, cooled to 4°C	28 days
¹⁴ C of DIC	250 mL HDPE	None	28 days

Dissolved Gas Samples and Isotopic Analyses			
Dissolved Gas: N ₂ , CO ₂ , CO, O ₂ , Ar, H ₂ , He, CH ₄ , C ₂ H ₆ , C ₃ H ₈ , i-C ₄ H ₁₀ , n-C ₄ H ₁₀ , i-C ₅ H ₁₂ , n-C ₅ H ₁₂ and C ₆ +	0.6 L IsoFask [®]	None	1 year
δ ¹³ C of dissolved CO ₂ , C ₁ -C ₅ , δ ² H of CH ₄	0.6 L IsoFask [®]	None	1 year
¹⁴ C of CH ₄	0.6 L IsoFask [®]	None	1 year
Dissolved CO ₂	No Container needed - Calculated from Alkalinity Analysis		
Dissolved Gas: H ₂ S	500 mL Plastic	Cooled to 4°C, sodium hydroxide	7 days
Composition and isotope noble gas: Ar, Kr, Xe, Ne, He, ³ He/ ⁴ He ratio, ²⁰ Ne/ ²² Ne ratio, ³⁶ Ar/ ⁴⁰ Ar ratio	2 cm x 20 cm Copper Tube	None	> 365 days

****Field QC of groundwater**

QC Sample Type	Frequency
Field Duplicate	10% of the Primary Samples (minimum of 1 sample per field mobilization and sample zone)
Field Blank ¹	1 per sampling field mobilization
Equipment Blank ¹	1 per equipment or type of supplies, if non-dedicated equipment is used

¹QC sample collected for the lowermost USDW monitoring program only.

- External Mechanical Integrity Testing:** The Permittee must demonstrate external mechanical integrity annually as described in the approved Testing and Monitoring Plan and must comply with Section L of this Permit to meet the requirements of 40 CFR 146.89 and 146.90.

Summary of Internal and External Mechanical Integrity Testing in Injector Wells

Internal Mechanical Integrity			
Method	Pre-Injection	Injection	Post-Injection
Annular pressure test	During construction and prior to injection	At least once every five years, during well maintenance; and before plugging	NA
DTS	Prior to injection	Continuously	NA
External Mechanical Integrity			
Method	Pre-Injection	Injection	Post-Injection
Temperature log	Prior to injection	Annually	NA
DTS	Prior to injection	Continuously	NA

Internal and External Mechanical Integrity Monitoring Methods in SLR and WW wells

Internal Mechanical Integrity			
Method	Pre-Injection	Injection	Post-Injection
Annular pressure test	Prior to injection	Annually and before plugging	At least once every five years, during workovers; and before plugging
Downhole P/T gauges	Prior to injection	Continuously	Continuously for the first 10 years, then annually until plugging
External Mechanical Integrity			
Method	Pre-Injection	Injection	Post-Injection

Temperature log or other methods: Cement Bond Log (CBL), Variable Density Log, UltraSonic Imager Tool (USIT™), Isolation Scanner™, Electromagnetic Pipe Examiner, Casing Inspection Log*	Prior to injection	At least one method once every five years, during well maintenance and before plugging	At least one method once every five years, during workovers; and before plugging
Downhole P/T gauges	Prior to injection	Continuously	Continuously for the first 10 years, then annually until plugging

*** Representative logging tool specifications for mechanical integrity tools**

Parameter	Injectors	SLR, ACZ and WW			
	Temperature Log	Isolation Scanner	UltraSonic Imager Tool	Cement Bond Log	Variable Density Log
Logging speed	<1800 ft/hr	<2,700 ft/hr	<1,800 ft/ hr	<3,600 ft /hr	<3,600 ft/hr
Depth of investigation	Wellbore	Casing and annulus up to 3 in	Casing to cement interface	Casing and cement interface	Depends on bonding and formation
Vertical resolution	Point measurement	0.6 - 6 in	0.6 – 6 in	3 ft	5 ft
Range of measurement	0 – 350 °F	0.15 - 0.79 in	0 - 10 MRayl	0 – 100+mV	Waveform recording
Temperature rating	350 °F	350 °F	350 °F	350 °F	350 °F
Pressure rating	20,000 psi	20,000 psi	20,000 psi	20,000 psi	20,000 psi

7. **Casing Inspection Logs:** Casing inspection logs shall be run whenever the owner or Permittee conducts a workover in which the injection string is pulled unless the Director

waives this requirement due to well construction or other factors that limit the test's reliability or based upon the satisfactory results of a casing inspection log run within the previous five years. The Director may require that a casing inspection log be run every year if the Director has reason to believe that the integrity of the long string casing of the well may be adversely affected by naturally occurring or human-induced events. If corrosion coupon data indicates potential loss of material strength or performance inconsistent with operating standards, the Permittee shall report it to the Director and run a casing inspection log.

8. **Pressure Fall-Off Test:** The Permittee shall conduct a pressure fall-off test at least once every five years unless more frequent testing is required by the Director based on site-specific information. The test shall be performed as described in the Testing and Monitoring Plan to meet the requirements of 40 CFR 146.90(f).

Summary of Pressure Fall-Off Testing

Method	Pre-Injection	Injection	Post-Injection
Fall-off Testing	Prior to injection	At least once every five years during workovers	N/A

9. **Carbon Dioxide Plume and Pressure Front Tracking:** The Permittee must track the extent of the carbon dioxide plume and pressure front once injection begins, using direct and indirect monitoring methods as described in the approved Testing and Monitoring Plan and in accordance with 40 CFR 146.90(g). The Permittee is required to conduct this monitoring to detect and locate the carbon dioxide pressure front and the dissolved carbon dioxide plume and the data will be used to calibrate the AoR model to determine whether modifications to the AoR need to be made. The data collected will be used to monitor the location of the plume and pressure front, evaluate its movement through time, and compare it to the plume and pressure front predictions of the AoR model.

Summary of Direct and Indirect Methods of Tracking the CO2 Plume and Pressure Front

Direct Methods				
Objective	Method	Pre-Injection	Injection	Post-Injection
Measure geochemical composition of the Injection	Fluid and dissolved gas sampling in SLR2 and SLR3	Quarterly for at least one year	Event-driven	Event-driven until plugging

Zone	wells			
	Fluid and dissolved gas sampling in USDW-level well	Quarterly for at least one year	Quarterly during years 1-3; annually starting in year 4	Annually for first 10 years
	Fluid sampling in WW wells	Quarterly for at least one year	Event-driven	N/A
Measure P/T of the Injection Zone	P/T using gauges and/or DTS in SLR2 and SLR3 wells	Prior to injection	Continuous	Continuously for the first 10 years
Indirect Methods				
Objective	Method	Pre-Injection	Injection	Post-Injection
Estimate CO ₂ saturation in the Injection Zone	PNL or RST in INJ wells*	Prior to injection	Event-driven	NA
	PNL or RST in SLR2 and SLR3 wells	Prior to injection	Annually	Annually until plugging
	PNL or RST in WW wells	Prior to injection	Once every five-year period	NA
Estimate CO ₂ plume and pressure extent in the Injection Zone	2D VSP in INJ Wells**	Prior to injection	2D VSP at years 1, 2, 5 and 10	NA
	2D VSP in selected SLR wells	Prior to injection	2D VSP in year 5 or 10	Once approximately every five-year period until plugging or plume stabilization
	2D surface seismic	Prior to injection	Year 10	Once approximately every five-year period until plume stabilization
	DInSAR with	Prior to injection	Quarterly	Annually for five years or until plume

	GPS***			stabilizes
	Computational modeling	Prior to injection	As needed, to be used for AoR re-evaluation	As needed, to be used for AoR re-evaluation

***Representative logging tool specifications for Reservoir Saturation Tools**

Parameter	PNX Pulsar – Pulsed Neutron (Schlumberger)	RMT-3D Pulsed Neutron (Halliburton)
Acquisition	Real time	Real time
Logging speed	200 to 3,600 ft/hr	180 to 900 ft/hr
Depth of investigation	3 - 10 in	6 to 12 in.
Vertical resolution	3 ft	30 in.
Range of measurement	0 to 60 pu	5 to 60 pu
Temperature rating	350°F	325°F
Pressure rating	15,000 psi	15,000 psi

****Summary of measurement parameters for Vertical Seismic Profiles**

Parameter	Value
Horizontal Accuracy	< 6 feet
Detection limit	< 40 microseconds
DAS recording gauge length	32 feet
DAS receiver spacing	16 feet
Source spacing	82 feet

*****Summary of DInSAR and GPS sampling plans**

Objective	Method	Minimum sampling frequency	Minimum recording frequency
Measure surface displacement	DInSAR	Quarterly	Image recording bi-weekly
	GPS	Quarterly	Quarterly

- a. Direct Methods: The Permittee must use the deep monitoring well to continuously record the pressure and temperature of the injection zone formation to track the position of the carbon dioxide pressure front, collect fluid samples from the injection zone formation to track the position of the carbon dioxide plume described in the approved Testing and Monitoring Plan, and meet the requirements of 40 CFR 146.90(g)(1).

Summary of Direct Monitoring Methods

Objective	Method	Frequency pre-injection	Frequency during injection	Frequency post-injection
Pressure and temperature monitoring downhole	Downhole gauge ported to tubing and ported to annulus in injection wells	Prior to injection	Continuously, 10 second sampling and 5 minute recording frequency	Continuously for the first 10 years then annually until plugging 10 second sampling and 5 minute recording frequency
	DTS (planned for SLR2 and possibly SLR3)	Prior to injection	Continuously, 10 minute sampling and 30 minute recording frequency	Continuously for the first 10 years then annually until plugging 10 minute sampling and 30 minute recording frequency
Pressure and temperature monitoring at surface	Surface gauge at injection well wellhead	Prior to injection	Continuously, 1 second sampling and 30 second recording frequency	Continuously for the first 10 years then annually until plugging, 1 second sampling and 30 second recording frequency
Saturation profile	PNL or RST logging in SLR2 and SLR3 and WWs	Before injection	Annually in SLR2 and SLR3; event driven in WWs	Annually until plugging

Fluid and dissolved gas geochemistry	Fluid and dissolved gas sampling and analysis in SLR2 and SLR3	During construction of injector wells, SLR wells and WWs and prior to injection to establish characterization	In SLR2 and SLR3, or WWs; Event-driven, triggered by P/T data	Event-driven, triggered by P/T data
--------------------------------------	--	---	---	-------------------------------------

- b. Indirect Methods: The Permittee must use indirect monitoring methods to track the position of the carbon dioxide plume and pressure front as described in the approved Testing and Monitoring Plan and to meet the requirements of 40 CFR 146.90(g)(2).

Summary of Indirect Monitoring Methods

Objective	Method	Frequency pre-injection	Frequency during injection	Frequency post-injection
First Permeable zone above the confining zone / lowermost USDW: Dockum				
Fluid and dissolved gas geochemistry in the first permeable zone above the confining zone	Fluid and dissolved gas sampling and analysis in USDW1	During construction and quarterly during baseline	Quarterly geochemical sampling in years 1-3 and annually starting in year 4; and event-driven, triggered by P/T in SLR wells or soil gas chemistry	Annually for first 10 years; and event-driven, triggered by P/T in SLR wells or soil gas chemistry
Upper Confining Zone integrity				
Estimate CO2 saturation in the Upper Confining Zone	PNL or RST in SLR1 and ACZ1	Prior to injection	Every five years	Event-driven
Pressure and temperature in the Upper Confining Zone	DTS in SLR1	Prior to injection	Continuous measurement and recording of pressure and temperature	Event-driven

10. Surface Air and/or Soil Gas Monitoring: In addition to the testing and monitoring outlined in this Permit and in the applicable regulations, the Permittee voluntarily proposes surface air monitoring and/or soil gas monitoring to detect potential movement of carbon dioxide that could endanger a USDW in Attachment 6. Should the Director deem this monitoring necessary, the Testing and Monitoring Plan must be amended to be reflective of the frequency and locations the Director requires and must meet the requirements of 40 CFR 146.90(h).

Summary of Soil Gas Monitoring

Objective	Method	Frequency pre-injection	Frequency during injection	Frequency post-injection
Soil gas analysis in the near-surface vadose zone	Isotopic analysis and chemical evaluation at approximately 21 locations*,**	Characterization prior to injection, including quarterly sampling for at least one year	Quarterly gas composition sampling in years 1-3 and annually starting in year 4 for subset of stations, and event-driven, triggered by P/T data in SLR wells and fluid sample results	Event-driven, triggered by P/T data in SLR wells and fluid sample results

***Summary of analytical parameters for soil and soil gas samples**

Parameters	Analytical Methods	Detection Limit / Range	Typical Precision	QC Requirements
pH	EPA Method 9045D	0-14 pH Std Unit	±0.1	Lab Control/ Lab Control Duplicate, Matrix Spike/ Matrix Spike Duplicate samples, instrument calibration, field duplicates
Electrical conductivity (EC)	29B_EC	5 umhos/cm	20	Lab Control/ Lab Control Duplicate, Matrix Spike/ Matrix Spike Duplicate samples, instrument calibration, field duplicates

Sodium Adsorption Ratio (SAR)	29B SAR	0.01 meq/meq	±20%	Lab Control/ Lab Control Duplicate, Matrix Spike/ Matrix Spike Duplicate samples, instrument calibration, field duplicates
Moisture	SM 2540 B	0.1 - 100%	±20%	Lab Control/ Lab Control Duplicate, Matrix Spike/ Matrix Spike Duplicate samples, instrument calibration, field duplicates
Total Organic Carbon (TOC)	Walkley Black 9060A	0.02 wt%	±20%	Lab Control/ Lab Control Duplicate, Matrix Spike/ Matrix Spike Duplicate samples, instrument calibration, field duplicates
Soil Gas Samples				
Gas: H ₂ , He, O ₂ , N ₂ , CO ₂ , CH ₄ , CO, Ar, C ₂ -C ₆ +	Third party lab SOP, similar to RSK-175	CO ₂ : 50 ppm N ₂ and O ₂ : 100 ppm CH ₄ : 2 ppm C ₂ - C ₆ +: 1ppm 50 ppm	for CO ₂ (> 1.5%) ±0.6% (of measured value) for CO ₂ (< 0.05%) ±1.7% (of measured value) for N ₂ and O ₂ (>10%) ±0.5% (of measured value) CH ₄ : ±0.4 to 1% (of measured value) C ₂ - C ₄ : ±0.4 to 1% (of measured value) C ₅ - C ₆ +: ±2 to 4% (of measured value) for He: ±2% (of measured value)	At a rate of 20% of the samples analyzed: A lab check standard or sample duplicate is analyzed every 5th run with a lab standard being run first every day. Method based on ASTM D1945.
¹⁴ C of CO ₂ +	AMS - subcontracted to Beta Analytic	0.44pMC	0.02 pMC - 0.5 pMC	At a rate of 20% of the samples analyzed: A lab check standard or sample duplicate is analyzed every 5th run with a lab standard being run first every day.

$\delta^{13}\text{C}$ of CH_4 and CO_2 , $\delta^2\text{H}$ of Methane†	High precision (offline) analysis via Dual Inlet IRMS	Varies by component	$\delta^{13}\text{C}$: 0.1 per mil $\delta^2\text{H}$: 3.5 per mil	Frequent calibration, method blank, lab control samples, matrix spikes and sample duplicate. At least one secondary standard is measured with each sample batch and approx. 10% of samples submitted are prepared and measured a second time.
Soil Gas Field Analysis				
Hydrogen Sulfide (field)	EPA Method 21	0 to 100 ppm	$\pm 5\%$ of reading or ± 2 ppm	User calibration per manufacturer recommendation

†Analytical parameters to be included during the pre-injection phase, and only as needed during the injection and post-injection phases.

****Containers, preservation techniques and holding times for soil gas and soil samples**

Sample Type	Container and volume	Preservation Technique	Max Holding Time
Soil Samples			
pH	16 oz. clear glass jar	Cooled to 4°C	24 hours
Electrical conductivity (EC)	16 oz. clear glass jar	Cooled to 4°C	180 days
Sodium Adsorption Ratio (SAR)	16 oz. clear glass jar	Cooled to 4°C	180 days
Moisture	16 oz. clear glass jar	Cooled to 4°C	60 days
Soil Gas Samples			
Gas: H_2 , He, O_2 , N_2 , CO_2 , CH_4 , CO, Ar, $\text{C}_2\text{-C}_6+$	0.3-L IsoBag Gas Bag®	None	180 days
^{14}C of CO_2	0.3-L IsoBag Gas Bag®	None	180 days
$\delta^{13}\text{C}$ of Methane and CO_2 , $\delta^2\text{H}$ of Methane	0.3-L IsoBag Gas Bag®	None	180 days

11. **Additional Monitoring:** If required by the Director as provided in 40 CFR 146.90(i), the Permittee must perform any additional monitoring determined to be necessary to support, upgrade, and improve computational modeling of the AoR evaluation required under 40 CFR 146.84(c) and to determine compliance with standards under 40 CFR

144.12 or 146.86(a). This monitoring must be performed as described in a modification to the Testing and Monitoring Plan.

- a. The Permittee shall deploy a seismometer network to determine the locations, magnitudes, and focal mechanisms of any injection-induced seismic events in case they occur. This information will be used to address public concerns and to monitor for induced seismicity risks and through adjustment of well operations as needed.

Summary of Measurement Parameters for Seismometers

Parameters	Value
Nominal Sensitivity	750 V-s/m
Precision	±0.5%
Bandwidth/120s	-3 dB points at 120 s and 108 Hz
Bandwidth/20s	-3 dB points at 20 s and 108 Hz
Off-axis Sensitivity	±0.5%
Clip Level	26 mm/s up to 10 Hz and 0.17 g above 10 Hz
Operating Tilt Range/120s	±2.5°
Operating Tilt Range/20s	±10°
Parasitic Resonances	None below 200 Hz
Dynamic Range	> 152 dB @ 1 Hz

N. REPORTING AND RECORDKEEPING

The Permittee must submit reports at frequencies described in the approved Testing and Monitoring Plan, and as required by this Permit, even when the well is not operating. Reports must contain all the data and information required to be monitored, gathered, and reported by this Permit and meet the requirements of 40 CFR 144.17, 144.51(l), 144.54(c), and 146.91.

1. **Electronic Reporting:** The permittee must electronically submit all required reports to the GSDT and make and retain all reports, submittals, notifications, records, and correspondence to the EPA madunder this Permit in electronic format. Electronic reports, submittals, and records made and maintained by the permittee under this permit must be in an electronic format approved by EPA. The permittee shall electronically submit all required reports to the Director through the Geologic Sequestration Data Tool (GSDT). Required notifications prior to any work, testing, or procedures shall be submitted to R6ClassVI@epa.gov.
2. **Semi-Annual Reports:** The Permittee must submit reports on a semi-annual basis in accordance with 40 CFR 146.91(a). The reporting period for semi-annual reports will be from January 1 through June 30 and from July 1 through December 31. Reports must be submitted within 30 days of the end of each reporting period. Semi-annual reports must include all data collected on a continuous, daily, monthly, quarterly, and semi-annual basis as described in the approved Testing and Monitoring Plan. The second semi-annual report for each year must include all data collected on an annual basis as described in the approved Testing and Monitoring Plan. Reports must contain the following information and data, as well as all other information and data collected not listed below, but as described in the approved Testing and Monitoring Plan or in this Permit:
 - a. Any changes to the physical, chemical, and other relevant characteristics of the carbon dioxide stream from the proposed operating data;
 - b. Monthly average, maximum, and minimum values for injection pressure, flow rate and daily volume, temperature, and annular pressure;
 - c. A description of any event that exceeds operating parameters for annulus pressure or injection pressure specified in this Permit;
 - d. A description of any event which triggers the shut-off systems required in Section K of this Permit pursuant to 40 CFR 146.88(e), and the response taken;
 - e. The monthly mass of the carbon dioxide stream injected over the reporting period and the mass injected cumulatively over the life of the project;

- f. Monthly annulus fluid volume added or produced; and
- g. Results of the continuous monitoring required in Section M including:
 - i. A tabulation of (1) daily maximum injection pressure, (2) daily minimum annulus pressure, (3) daily minimum value of the difference between simultaneous measurements of annulus and injection pressure, (4) daily mass of injectate, (5) daily maximum flow rate, and (6) average annulus tank fluid level; and
 - ii. Graph(s) of the continuous monitoring as required in Section M of this Permit, or of daily average values of these parameters. The injection pressure, injection mass, flow rate, annulus fluid level, annulus pressure, and temperature must be submitted on one or more graphs, using contrasting symbols or colors or in another manner approved by the Director.
- h. Results of any additional monitoring identified in the approved Testing and Monitoring Plan and described in Section M of this Permit.

3. **24-Hour Reporting:**

- a. The Permittee must report to the Director any permit noncompliance that may endanger human health or the environment and any events that require implementation of actions in the Emergency and Remedial Response Plan (Attachment 9). Any information must be provided within 24 hours from the time the Permittee becomes aware of the circumstances. Such reports must include, but need not be limited to the following information:
 - i. Any evidence that the injected carbon dioxide stream or associated pressure front may cause an endangerment to a USDW, or any monitoring or other information which indicates that any contaminant may cause endangerment to a USDW;
 - ii. Any noncompliance with a permit condition, or malfunction of the injection system, which may cause fluid migration into or between USDWs;
 - iii. Any triggering of the shut-off system required in Section K of this Permit (i.e., down-hole or at the surface);
 - iv. Any failure to maintain mechanical integrity;
 - v. Pursuant to compliance with the requirement at 40 CFR 146.90(h) for surface air/soil gas monitoring or other monitoring technologies, if required by the Director, any release of carbon dioxide to the atmosphere or biosphere;

- vi. Actions taken to implement appropriate protocols outlined in the Emergency and Remedial Response Plan; and
 - vii. Any change in the status of the well.
- b. A written submission must be provided to the Director in an electronic format within five days of the time the permittee becomes aware of the circumstances described in Section O of this Permit. The submission must contain a description of the noncompliance, emergency, or remedial response and its cause; the period of noncompliance, emergency, or remedial response, including exact dates and times, and, if the noncompliance has not been corrected, the anticipated time it is expected to continue as well as actions taken to implement appropriate protocols outlined in the Emergency and Remedial Response Plan; and steps taken or planned to reduce, eliminate and prevent recurrence of the noncompliance or emergency or condition requiring remedial response.
4. **Reports on Well Tests and Workovers:** Report, within 30 days, the results of:
- a. Periodic tests of mechanical integrity;
 - b. Any well workover, including stimulation;
 - c. Any other test of the injection well conducted by the Permittee if required by the Director; and
 - d. Any test of any monitoring well required by this Permit.
5. **Advance Notice Reporting:**
- a. **Well Tests:** The Permittee must give the director at least 30 days' advance written notice in electronic format of any planned workover, stimulation, or other well test.
 - b. **Planned Changes:** The Permittee must give written notice to the Director in electronic format as soon as possible of any planned physical alterations or additions to the permitted facility. An analysis of any new injection fluid must be submitted to the Director for review and written approval at least 30 days prior to injection; this approval may result in a permit modification.
 - c. **Anticipated Noncompliance:** The Permittee must give at least 14 days advance written notice to the Director in an electronic format of any planned changes in the permitted facility or activity that may result in noncompliance with permit requirements.
6. **Additional Reports:**

- a. **Compliance Schedules:** The Permittee must submit in electronic format no later than 30 days following each scheduled date reports of compliance or noncompliance with, or any progress reports on, interim and final requirements contained in any compliance schedule of this Permit.
 - b. **Transfer of Permits:** This Permit is not transferable to any person except after notice is sent to the Director in an electronic format at least 30 days prior to transfer and the requirements of 40 CFR 144.38(a) have been met. Pursuant to requirements at 40 CFR 144.38(a), the Director will require modification or revocation and reissuance of the permit to change the name of the Permittee and incorporate such other requirements as may be necessary under the SDWA. All FR cost estimates, documentation, and instruments, as required by 40 CFR 146.85 and by Section H of this Permit, must be updated and provided to the Director by any new owner of the well.
 - c. **Other Noncompliance:** The Permittee must report in an electronic format all other instances of noncompliance not otherwise reported with the following monitoring report. The reports must contain the information listed in Section N of this Permit.
 - d. **Other Information:** When the Permittee becomes aware of a failure to submit any relevant facts in the permit application or that incorrect information was submitted in a permit application or in any report to the Director – including new or changed information about site geology – the Permittee must submit such facts or information in an electronic format within 10 days of discovery per 40 CFR 144.51(l)(8).
 - e. **Report on Permit Review:** Within 30 days of receipt of this Permit, the Permittee must certify to the Director in electronic format that he or she has read and is personally familiar with all its terms and conditions.
7. **Records and Record Retention:**
- a. The Permittee must retain records and all monitoring information, including all calibration and maintenance records, all original chart recordings for continuous monitoring instrumentation, and copies of all reports required by this Permit (including records from pre-injection, active injection, and post-injection phases), for at least 10 years from collection.
 - b. The Permittee must maintain records of all data required to complete the permit application form for this Permit and any supplemental information (e.g., modeling inputs for AoR delineations and reevaluations, plan modifications) submitted under 40 CFR 144.31, 144.39, and 144.41 until least 10 years after site closure.

- c. The Permittee must retain records concerning the nature and composition of all injected fluids until 10 years after site closure.
 - d. The retention periods specified in Section N of this Permit may be extended at the request of the Director at any time. The Permittee must continue to retain records after the retention period specified in this Section of the Permit or any requested extension thereof expires unless the Permittee delivers the records to the Director or obtains written approval from the Director to discard the records.
 - e. Records of monitoring information must include:
 - i. The date, exact place, and time of sampling or measurements;
 - ii. The name(s) of the individual(s) who performed the sampling or measurements;
 - iii. A precise description of both sampling methodology and the handling of samples;
 - iv. The date(s) analyses were performed;
 - v. The name(s) of the individual(s) who performed the analyses;
 - vi. The analytical techniques or methods used; and
 - vii. The results of such analyses.
8. **Signatory and Certification Requirements:** All reports, notifications, or any other information, required to be submitted by this Permit or requested by the Director shall be signed and certified in accordance with 40 CFR 144.32. The Permittee shall ensure that all signed documents include the following certification statement: "I certify under penalty of law that this document and all attachments were prepared under my direction or supervision in accordance with a system designed to assure that qualified personnel properly gather and evaluate the information submitted. Based on my inquiry of the person or persons who manage the system, or those persons directly responsible for gathering the information, the information submitted is, to the best of my knowledge and belief, true, accurate, and complete. I am aware that there are significant penalties for submitting false information, including the possibility of fine and imprisonment for knowing violations."

O. WELL PLUGGING, POST-INJECTION SITE CARE, AND SITE CLOSURE

The Permittee must maintain and comply with the approved Well Plugging Plan highlighted in Attachment 7 and the approved Post Injection Site Care and Site Closure Plan referenced in Attachment 8 and must comply with the requirements of 40 CFR 146.92 and 146.93. The Well Plugging Plan and the Post-Injection Site Care and Site Closure Plan are enforceable conditions of this Permit.

1. **Well Plugging Plan Revisions:** If data indicate and the Permittee deems it necessary, or if the Director requires the approved plans of this Permit to be modified, revised plan(s) must be submitted in an electronic format to the Director for review and written approval. Any amendments to the Well Plugging Plan and/or the Post-Injection Site Care and Site Closure plan must be approved by the Director and must be incorporated into the permit and are subject to the permit modification requirements at 40 CFR 144.39 and/or 144.41.
2. **Required Activities Prior to Plugging:** The Permittee must flush the well with an inert buffer fluid, determine the post-injection bottom hole pressure, and perform final internal and external mechanical integrity tests prior to injection well plugging. These tests must be performed as required by Section L of this Permit.
3. **Notice of Plugging and Abandonment:** The Permittee must notify the Director in writing in an electronic format at least 60 days before plugging, conversion, or abandonment of the well, pursuant to 40 CFR 146.92 (c), and must provide the Director or their representative the opportunity to attend. A shorter notice period may be allowed at the discretion of the Director.
4. **Plugging and Abandonment Approval and Report:**
 - a. The Permittee must receive written approval from the Director before plugging the well and must plug and abandon the well as required by 40 CFR 146.92, as described in the approved Well Plugging Plan.
 - b. Within 60 days after plugging, the Permittee must submit a plugging report to the Director in electronic format. The report must be signed and certified by the Permittee per 40 CFR 144.32 and by the person who performed the plugging operation (if other than the Permittee.) The Permittee must retain the well-plugging report in an electronic format for 10 years following site closure. The report must include:
 - i. A statement that the well was plugged in accordance with the approved Well Plugging Plan; or

- ii. If the actual plugging differed from the approved plan, a statement describing the actual plugging and an updated plan specifying the differences from the plan previously submitted and explaining why the Director should approve such deviation. If the Director determines that a deviation from the plan incorporated in this Permit may endanger underground sources of drinking water, the Permittee must replug the well as required by the Director.
- 5. **Temporary Abandonment:** After any 24 consecutive month period of no injection, the well is considered to be in a temporarily abandoned status, and the Permittee must plug and abandon the well following the approved Well Plugging Plan, 40 CFR 144.52 (a)(vi) and 146.92 or make a demonstration of non-endangerment of this well that is satisfactory to the Director while it is in temporary abandonment status. The Director may request multiple demonstrations of non-endangerment while the well is in temporary abandonment status. Temporary abandonment status includes instances where well construction/conversion has begun but the Director has approved no authorization to commence injection. During any periods of temporary abandonment or disuse, the Permittee must continue to comply with the conditions of this Permit, including all monitoring and reporting requirements in compliance with all the requirements of this Permit and all applicable regulations. The Permittee must notify and receive approval from the Director prior to resuming operation of the well.
- 6. **Post-Injection Site Care and Site Closure Plan:** The Permittee must maintain and comply with the proposed Post-Injection Site Care and Site Closure Plan of this Permit and comply with the requirements of 40 CFR 146.93. The default post-injection site care period is 50 years, which is an enforceable condition of this permit. If the Permittee elects to propose an alternative post-injection site care period, either within the initial application or at a later date, they will be required to demonstrate that the carbon dioxide injection poses no threat to USDWs.
 - a. Upon cessation of injection, the Permittee must demonstrate, through monitoring data and modeling results, that the proposed 50-year post-injection site care period within the Permittee's application requires no amendment or submit an amended Post-Injection Site Care and Site Closure Plan, either which must be submitted in electronic format for the Director's approval.
 - b. At any time during the life of the project, the Permittee may modify and resubmit in an electronic format the Post-Injection Site Care and Site Closure Plan for the Director's approval per 40 CFR 146.93(a)(3). As part of such modifications to the Plan, the Permittee may request a modification to the post-injection site care timeframe that includes documentation of the information at 40 CFR 146.93(c)(1).

- c. The monitoring, as outlined in the approved Post-Injection Site Care and Site Closure Plan, must define the position of the carbon dioxide plume and pressure front, compare the data collected to the predictions made by the AoR model, and demonstrate that USDWs are not being endangered per 40 CFR 146.90 and 146.93.
- d. Prior to authorization for site closure, the Permittee must submit to the Director for review and approval, in an electronic format, a demonstration utilizing both monitoring data and modeling results that the carbon dioxide plume and the associated pressure front do not pose an endangerment to USDWs and that no additional monitoring is needed to ensure that the project does not pose an endangerment to USDWs, as required under 40 CFR 146.93(b). The Director reserves the right to amend the post-injection site monitoring requirements (including an extension of the monitoring period) if there is a concern that USDWs are at risk of endangerment.
- e. The Permittee must notify the Director in an electronic format at least 120 days before site closure. At this time, if any changes to the previously approved Post-Injection Site Care and Site Closure Plan are proposed, the Permittee must submit a revised plan.
- f. After the Director has authorized site closure, the Permittee must plug all monitoring wells as specified in Section O of this Permit in a manner that will not allow movement of injection or formation fluids to endanger a USDW. The Permittee must also restore the site to its pre-injection condition.
- g. The Permittee must submit a site closure report in an electronic format to the Director within 90 days of site closure. The report must include the information specified in 40 CFR 146.93(f).
- h. The Permittee must record a notation on the deed to the facility property or any other document that is normally examined during a title search that will, in perpetuity, provide any potential purchaser of the property the information listed at 40 CFR 146.93(g). The Permittee must retain for 10 years following site closure an electronic copy of the site closure report, records collected during the post-injection site care period, and any other records required under 40 CFR 146.91(f)(4). The Permittee must deliver the records in an electronic format to the Director at the conclusion of the retention period.

P. EMERGENCY AND REMEDIAL RESPONSE

The Emergency and Remedial Response Plan describes actions the Permittee must take to address events that may cause the movement of the injection or formation fluids that may cause an endangerment to a USDW during construction, operation, and post-injection site care periods. The Permittee must maintain and comply with the approved Emergency and Remedial Response Plan referenced in Attachment 9 of this Permit, which is an enforceable condition of this Permit, and with 40 CFR 146.94. A copy of the Emergency and Remedial Response Plan must be kept on-site at the facility, and staff contact lists must be reviewed annually to confirm contact information is current.

1. If the data collected provides evidence that the carbon dioxide stream and/or pressure front may cause endangerment to a USDW, the Permittee must:
 - a. Cease injection per Section K and Attachments 1 and/or 9 of this Permit;
 - b. Take all reasonable steps necessary to identify and characterize any release from the underground injection system;
 - c. Notify the Director within 24 hours; and
 - d. Implement the approved Emergency and Remedial Response Plan in (Attachment 9 of this Permit) approved by the Director.

2. At the frequency specified in the Area of Review and Corrective Action Plan or more frequently if the monitoring and operational data warrant, the Permittee must review and update the Emergency and Remedial Response Plan as required at 40 CFR 146.94(d) or demonstrate to the Director that no update is needed. The Permittee must incorporate monitoring and operational data in AoR reevaluations required under Section G of this Permit or demonstrate to the Director that no update is needed. In no case shall the owner or Permittee review the emergency and remedial response plan less often than once every five years. The amended Emergency and Remedial Response Plan or demonstration must be submitted to the Director in an electronic format within one year of an AoR reevaluation, following any significant changes to the facility such as, but not limited to, the addition of injection wells, or when required by the Director. If the amendments to the Emergency and Remedial Response Plan cause the cost estimates to change, then a new Financial Responsibility Demonstration must be submitted for review and approval by the Director in accordance with Section H of this Permit.

3. Following each update of the Emergency and Remedial Response Plan or a demonstration that no update is needed, the Permittee must submit the resultant information in an electronic format to the Director within 30 days for review and confirmation of the results. Once approved by the Director, the revised Emergency and Remedial Response Plan will become an enforceable condition of this Permit.

Q. SEISMIC EVENT RESPONSE

The Permittee shall closely monitor seismic activity and implement a pause to operations or continue operations at a reduced rate should analysis indicate a causal relationship between injection operations and detected seismicity. The Permittee, in consultation with the UIC Program Director, will determine whether immediate or gradual cessation of injection is appropriate.

If seismic events are recorded by either the local private array or a public array (national or state) in the vicinity of the injection well, the Permittee shall implement the response plan subject to detected earthquake magnitude limits defined in the referenced Emergency and Remedial Response plan (Attachment 9) to eliminate or reduce the magnitude, frequency and/or effects of seismic events. Consistent with permitting criteria in the State of Texas for injection wells, a 5.6-mile radius around the injection well will be used.

Texas Administrative Codes require disposal wells to include a review of USGS earthquake records around the proposed well location (a circular area with a radius of 9.08 kilometers, or 5.64 miles). The Permittee shall provide the Director with specific details of any private seismic array prior to injection, along with the availability of collected information.

R. COMMENCING INJECTION

The Permittee may not commence injection until:

1. Results of the formation testing and logging program, as specified in Section J of this Permit and in 40 CFR 146.87, are submitted to the Director in an electronic format and subsequently reviewed and approved by the Director;
2. Mechanical integrity of the well has been demonstrated in accordance with 40 CFR 146.89(a)(1) and (2), and in accordance with Section L of this Permit;
3. The completion of corrective action required by the Area of Review and Corrective Action Plan highlighted in Attachment 2 of this Permit in accordance with 40 CFR 146.84;
4. All requirements at 40 CFR 146.82(c) have been met, including but not limited to reviewing and updating the Area of Review and Corrective Action, Financial Assurance, Testing and Monitoring, Well Plugging, Post-Injection Site Care and Site Closure, and Emergency and Remedial Response plans to incorporate final site characterization information, final delineation of the AoR, and the results of pre-injection testing, and information has been submitted in an electronic format, reviewed and approved by the Director;
5. The Permittee's financial instruments are fully effective in accordance with Attachment 3 of this Permit;
6. The Permittee has submitted to and received approval from the Director in an electronic format a notice that all construction is complete and in compliance with 40 CFR 146.86 and the conditions of this Permit;
7. The Director has approved the demonstration of the alarm system and shut-off system under Section K of this Permit; and.
8. The Director has given written authorization to commence injection.

ATTACHMENTS

ATTACHMENT 1: SUMMARY OF OPERATING REQUIREMENTS

Facility Information

Facility name: Brown Pelican CO2 Sequestration Project
BRP CCS2

Well location: Penwell, TX
31.76993805, -102.7332448

1.0 Injection Well Operating Conditions

Key injection well operating and project reporting requirements for the Brown Pelican CO2 Sequestration Project (BRP Project or Project) are specified in this document and summarized below in Table 1.

Table 1—Injection Well Operating Conditions

Parameter/Condition	Limitation or Permitted Value	Units
Daily group maximum injection mass	2,116	Metric tons per day
Daily group average injection mass	1,931	Metric tons per day
Daily maximum injection mass BRP CCS2	1,500	Metric tons per day
Daily average injection mass BRP CCS2	1,112	Metric tons per day
Daily maximum injection rate BRP CCS2	25.0	Million standard cubic feet per day
Daily average injection rate BRP CCS2	21.9	Million standard cubic feet per day
Total mass BRP CCS2	4.87	Million metric tons
Group maximum injection rate	773,000	Metric tons per year
Group average injection rate	705,000	Metric tons per year
Maximum injection rate BRP CCS2	481,000	Metric tons per year
Average injection rate BRP CCS2	406,000	Metric tons per year
Maximum surface wellhead injection pressure BRP CCS2	1,800	psig

Maximum bottomhole injection pressure BRP CCS2	3,391.8	psig
Average bottomhole injection pressure BRP CCS2	3,300	psig
Minimum annulus pressure	100	psig
Minimum annulus pressure/tubing differential	100	psig

Limitations or permitted values for the maximum surface wellhead injection pressure, maximum bottomhole injection pressure, minimum annulus pressure, and minimum annulus pressure/tubing differential limitation are set as follows:

- Maximum Surface Wellhead Injection Pressure:** CO₂ will be supplied by a dehydration and compression facility located approximately four miles northeast of the CO₂ Injector well location. The pressure at the facility discharge will be 2,500 psig. The CO₂ will then be routed via pipeline to valve stations near the injection well. Here the pressure will be reduced to 1,100 psig prior to reaching the wellhead. Pressure at the well will be controlled via control valves with shutdown protocols in place to protect the well in the event of a high-pressure scenario. Wellbore tubing pressure curves representative of the CO₂ Injector well will be created and calibrated after well construction.
- Maximum Bottomhole Injection Pressure:** To meet EPA requirements in 40 CFR §146.88(a), the maximum pressure considered for the CO₂ Injector well is 90% of the fracture opening pressure of the Injection Zone, measured using a downhole pressure gauge. The fracture pressure of the Injection Zone is determined from Step Rate Test data collected in the Shoe Bar 1AZ well that was drilled for the purposes of this Project. Reservoir modeling indicates the pore pressure required to move the effective stress state into tensile failure is near 3,785 psi at a depth of 5,115 ft below the ground surface. Maximum downhole injection pressure is therefore set to be less than 90% of that 3,785 psi threshold, calculated as follows:

$$0.9 \times 3,785 = 3,406.5 \text{ psia} - 14.7 \text{ psi} = 3,391.8 \text{ psig}$$

The maximum bottomhole injection pressure will be re-calculated based on logs and well information from the CO₂ Injection well after it is constructed.

- Minimum Annulus Pressure:** As necessary to prevent “burst” or “collapse” of the tubing, the minimum annulus pressure is calculated as follows:

Collapse Pressure = depth × [(pressure gradient of formation) + (pressure gradient of cement) – (pressure gradient of water)]

Burst Pressure = depth × (pressure gradient of injectant) + surface pressure

- **Minimum Annulus Pressure/Tubing Differential:** The annulus pressure/tubing differential is measured directly above and across the injection packer and is set to be a minimum of 100 psi above the surface wellhead injection pressure.

If the downhole pressure gauge fails to function properly, then the maximum injection pressure shall immediately be limited by the maximum surface wellhead injection pressure until the downhole pressure gauge can be repaired or replaced.

2.0 Reporting Frequencies

Oxy Low Carbon Ventures, LLC (OLCV) will maintain the reporting frequencies as summarized below in Table 2.

Table 2—Class VI Reporting Frequencies

Activity	Minimum Reporting Frequency
Change to the CO2 stream characterization	Semi-annually
Monthly injection pressure, flow rate, volume, pressure on the annulus, annulus fluid level, and temperature (Min, Max, and Avg.)	Semi-annually
Corrosion monitoring	Semi-annually
Monthly and cumulative volume and mass of the carbon dioxide stream injected	Semi-annually
Monthly annulus fluid volume added	Semi-annually
Results and reports for the monitoring systems proposed: plume tracking, above confining zone monitoring, surface monitoring	Semi-annually
Description of any event that triggers a shutoff device and the response taken	Semi-annually
Description of any event that exceeds operating parameters for annulus pressure or injection pressure specified in the permit	Semi-annually

Activity	Minimum Reporting Frequency
Any injectivity test performed in the well	Notification 30 days before and results within 30 days of completion of test
External Mechanical Integrity Test (MIT) and internal MIT*	Notification 30 days before and results within 30 days of completion of test
Pressure falloff testing	Notification 30 days before and results within 30 days of completion of test
Planned workover or well stimulation	Notification 30 days before and results within 30 days of completion of test
Monitoring well MITs	Notification 30 days before and results within 30 days of completion of test
Financial responsibility updates pursuant to H.2 and H.3(a) of this permit	Within 60 days of update

*Note: The reporting frequency for MIT will comply with TAC Title 16 Chapter 5.206(e)(1): “The operator of an anthropogenic CO2 injection well must maintain and comply with the approved monitoring, sampling, and testing plan to verify that the geologic storage facility is operating as permitted and that the injected fluids are confined to the injection zone.”

All testing and monitoring frequencies as well as methodologies are included in the Testing and Monitoring Plan document of this permit.

The events that trigger an immediate emergency response should be reported within 24 hours, according to the 40 CFR §146.91 reporting requirements.

3.0 Startup Monitoring and Reporting Procedures

The procedures related to the startup of operations, as well as monitoring and reporting during startup, are specified in this section. The injection rates will be gradually increased to the planned rate over a period of six (6) days.

The procedures detailed below describe how OLCV will initiate injection and conduct startup-specific monitoring of the CO2 Injector well, pursuant to 40 CFR §146.90.

The multistage (step-rate) startup procedure and period only apply to the initial start of injection operations until the well reaches the full injection rate. Monitoring frequencies and methodologies after the initial startup will follow the Testing and Monitoring Plan document of this permit.

- (1) This procedure will be performed using the existing surface and downhole pressure and temperature gauges in the CO₂ Injector well.
- (2) During the startup period, the permittee will submit a daily report summarizing and interpreting the operational data. At the request of the EPA, the permittee may be required to schedule a daily conference call to discuss this information.
- (3) A series of successively higher injection rates will be applied, as shown in Table 3 below in Step 4. The elapsed time and pressure values will be read and recorded for each rate and timestep. At no point during the procedure will the injection pressure be allowed to exceed the maximum injection pressure of 1,100 psig, which is measured at the wellhead.
- (4) The planned injection rates are shown in Table 3.

Table 3—Planned Injection Rates During Startup

Rate (tonnes per day)	Duration (hours)	Percent of Permit Maximum Injection Pressure (%)
493	24	40
617	24	50
740	24	60
863	24	70
986	24	80
1,110	24	90

- (5) The injection rates will be controlled with variable frequency drive pumps.
- (6) The injection rates will be measured and recorded using an orifice flowmeter.
- (7) Surface and downhole pressures and temperatures will be measured and recorded.
- (8) During the startup period, a plot of injection rates and their corresponding stabilized pressure values will be graphically represented, and the project team will look for any evidence of anomalous pressure behavior.
- (9) If during the startup period any anomalous pressure behavior is observed, additional logging and modification of the injection rate program may be conducted to characterize

the anomaly better. The project team will also determine if the observed anomalous pressure behavior indicates formation fracturing, which will cause the injection to cease and the line valve to be closed, allowing the pressure to bleed off into the injection zone, as discussed below:

- (a) The instantaneous shut-in pressure (ISIP) will be measured.
- (b) The permittee will notify the agency within 24 hours of the determination.
- (c) The permittee will consult with the agency before initiating any further injection.

4.0 Operations after startup

Automatic alarms and automatic shutoff systems will be installed and maintained. Successful function of the alarm system and shutoff system will be demonstrated prior to injection and once annually thereafter.

At all times, pressure will be maintained on the well to prevent the return of the injection fluid to the surface. The wellbore must be filled with a high-specific-gravity fluid during workovers to maintain a positive (downward) gradient and/or a plug shall be installed that can resist the pressure differential. A blowout preventer must be installed and kept in proper operational condition whenever the wellhead is removed to work on the well.

- OLCV shall cease injection should it appear that the well is lacking mechanical integrity or that the injected CO₂ stream and/or associated pressure front may cause an endangerment to a USDW.

Permittee will cease injection according to the guidelines provided below:

- OLCV must shut in the well by gradual reduction of the injection pressure as outlined in the Summary of Operating Conditions document of this permit; or
- OLCV must immediately cease injection and shut in the well as outlined in the Emergency and Remedial Response Plan document of this permit.

ATTACHMENT 2: AREA OF REVIEW AND CORRECTIVE ACTION PLAN

Facility name: Brown Pelican CO2 Sequestration Project
BRP CCS1, CCS2, and CCS3 wells

Well location: Penwell, TX

BRP CCS1	31.76479314	-102.7289311
BRP CCS2	31.76993805	-102.7332448
BRP CCS3	31.76031163	-102.7101566

1.0 Computational Modeling Approach

Pursuant to 40 CFR §146.86, this plan delineates the Area of Review (AoR) and describes the corrective action plans for wells that require corrective action. Delineation of the AoR is one of the key elements of the Class VI Rule to ensure Underground Sources of Drinking Water (USDW) in the region surrounding the geologic sequestration project may not be endangered by the injection activity.

The AoR is the region surrounding the geologic sequestration project where USDWs may be endangered by the injection activity. The AoR is delineated using multiphase CO₂-brine transport computational modeling, constructed from a geocellular model that accounts for the site-specific hydrogeology and the physical and chemical properties of all phases of the injected carbon dioxide stream and displaced fluids. The AoR delineation is based on available site characterization, monitoring, and operational data as set forth in §146.84. The methods and approaches for developing this complex multiphase simulation model and delineating the AoR are provided below.

1.1 Simulation Model Background

1.1.1 Geocellular Model Introduction

The characterization effort and geocellular modeling workflow undertaken for the Brown Pelican CO₂ Sequestration Project (BRP Project or Project) follows the industry-accepted best practices of Kerans and Tinker (1997). The geocellular model was constructed using Schlumberger's Petrel (v2021) geostatistical modeling software, which is a "reliable technology" for reserve estimation, as defined by the US Securities and Exchange

Commission (Society of Petroleum Engineers 2018). Application of this software has been reliably demonstrated in numerous peer-reviewed journals (e.g., Palermo et al. 2010; Rush and Rankey 2017; He et al. 2019) and from Carbon Capture and Sequestration investigations (e.g., Hosseini et al. 2012; Holubnyak et al. 2014).

1.1.2 Simulation Model Name and Authors

The model was created using the GEM (v2022.10) reservoir simulator with the Greenhouse Gas (GHG) module, from Computer Modeling Group Ltd. (CMG).

1.1.3 Description of the Simulation Model

GEM is a commercially available, compositional, finite-difference simulator that is commonly used to model hydrocarbon production, enhanced oil recovery, and other thermodynamic and fluid flow reservoir processes. GEM has also been used to model carbon capture and storage projects. The GEM's Greenhouse Gas (GHG) module accounts for the thermodynamic interactions between three phases: a H₂O-rich phase (liquid), CO₂-rich phase (gas), and a solid phase, which may include several minerals. Physical properties (e.g., density, viscosity, enthalpy) of the H₂O and CO₂ phases and CO₂ solubility in H₂O are calculated from a correlation suitable for a wide range of typical CO₂ storage formation conditions, including temperature ranges between 54°F and 300°F and pressures up to 16,000 psi. Details of this method can be found in Collins et al. (1992), Thomas and Thurnau (1983), and Nghiem and Li (1989).

The phase interactions throughout the simulations are governed as follows:

- The CO₂-rich phase (gas) density is obtained using the Peng-Robinson equation of state. The model was calibrated and modified as described in *Equation 1* (Peng and Robinson 1976).
- The CO₂ dissolution in brine is calculated from Henry's Law Constant Correlation using Harvey's method (Harvey 1996).
- The brine density is specified at a reference pressure of 2,200 psi. The brine viscosity is calculated using the Kestin et al. (1981) correlation.
- The CO₂ gas viscosity is calculated per the methods described by Pedersen et al. (1984).

The Peng-Robinson equation of state, as described above, takes this form:

$$p = \frac{RT}{v - b_{mix}} - \frac{a_{mix}}{v^2 + 2vb_{mix} - b^2}$$

Where, v is the molar volume, p is the pressure, T is the temperature in Kelvin, R is the universal gas constant, and a_{mix} and b_{mix} are the mixture-specific functions of temperature and composition calculated from the critical properties and acentric factors of the components. The CMG WinProp software used with GEM has a built-in library for the properties of CO₂ and CH₄, based on Reid et al. (1977). No changes were made to the library components.

The transition between liquid and gaseous CO₂ can lead to rapid density changes in the gas phase. The simulator uses a narrow transition interval between the liquid and gaseous density to represent the two-phase CO₂ region.

The compression facility controls the CO₂ delivery temperature to the injection well, keeping it between 70°F and 110°F. Consequently, the temperature of the injectant will be comparable to the reservoir formation temperature at the injection interval. Therefore, the simulations were based on isothermal operating conditions with a linear initial reservoir temperature gradient of 0.0072°F/ft and a surface temperature of 70°F.

With respect to the timestep selection, the software algorithm optimizes the timestep duration based on the specific convergence criteria designed to minimize numerical artifacts. For these simulations, the timestep size ranged from 0.001 days to 30 days. In all cases, the maximum solution change over a timestep is monitored and compared to a specified target. Convergence is achieved once the model reaches the maximum tolerance where small changes of the temperature and pressure calculation results occur on successive iterations. Timesteps are chosen so that the predicted solution change is less than the specified target.

1.2 Site Characteristics

1.2.1 Site Overview

A detailed regional and local geologic evaluation of the area around the BRP Project was conducted using geological, geophysical, and petrophysical data obtained from public literature, licensed data, and site-specific data collected for this project. These data are described in the following sections.

The BRP Project is located approximately 20 miles southwest of Odessa, Texas on the Shoe Bar Ranch. Part of the surface acreage is owned by OLCV, and the remaining acreage is leased by OLCV. OLCV conducted a surface assessment of the site to determine its suitability for CO₂ sequestration. The surface assessment included a review of high-resolution satellite imagery and high-resolution drone imagery to determine the presence or absence of surface water, springs, mines, or quarries. The United States Geological Survey (USGS) maintains a database of historical, current and prospective mines. The following sources were consulted to identify surface and near-surface

features:

- USGS Mineral Resources Data System¹
- High-resolution satellite imagery (licensed from Maxar)
- High-resolution drone imagery acquired in July 2023 for this Project

Based on review of these data, there are no springs, mines, or quarries in the BRP AoR. Two small ephemeral ponds are located outside of the AoR, but within the Shoe Bar Ranch.

Environmental Protection Agency (EPA), Texas Commission on Environmental Quality (TCEQ), and the Texas Railroad Commission (TRRC) databases were consulted to determine if the site contained groundwater contamination, industrial or hazardous waste facilities, petroleum tanks, superfund sites or brownfields.

- TCEQ Groundwater Contamination Viewer²
- TCEQ Industrial and Hazardous Waste Facility Viewer³
- TCEQ Petroleum Storage Tank Viewer⁴
- TCEQ Brownfields Viewer⁵
- TCEQ Superfund Sites Viewer⁶
- EPA Superfund Sites Viewer⁷
- TRRC Data (Including Brownfields) Viewer⁸

Based on a review of these data, there is no groundwater contamination, no industrial or hazardous waste sites, no petroleum storage tanks, no brownfields, and no superfund sites in the BRP AoR. Figure 1 shows surface features of the BRP Project site.

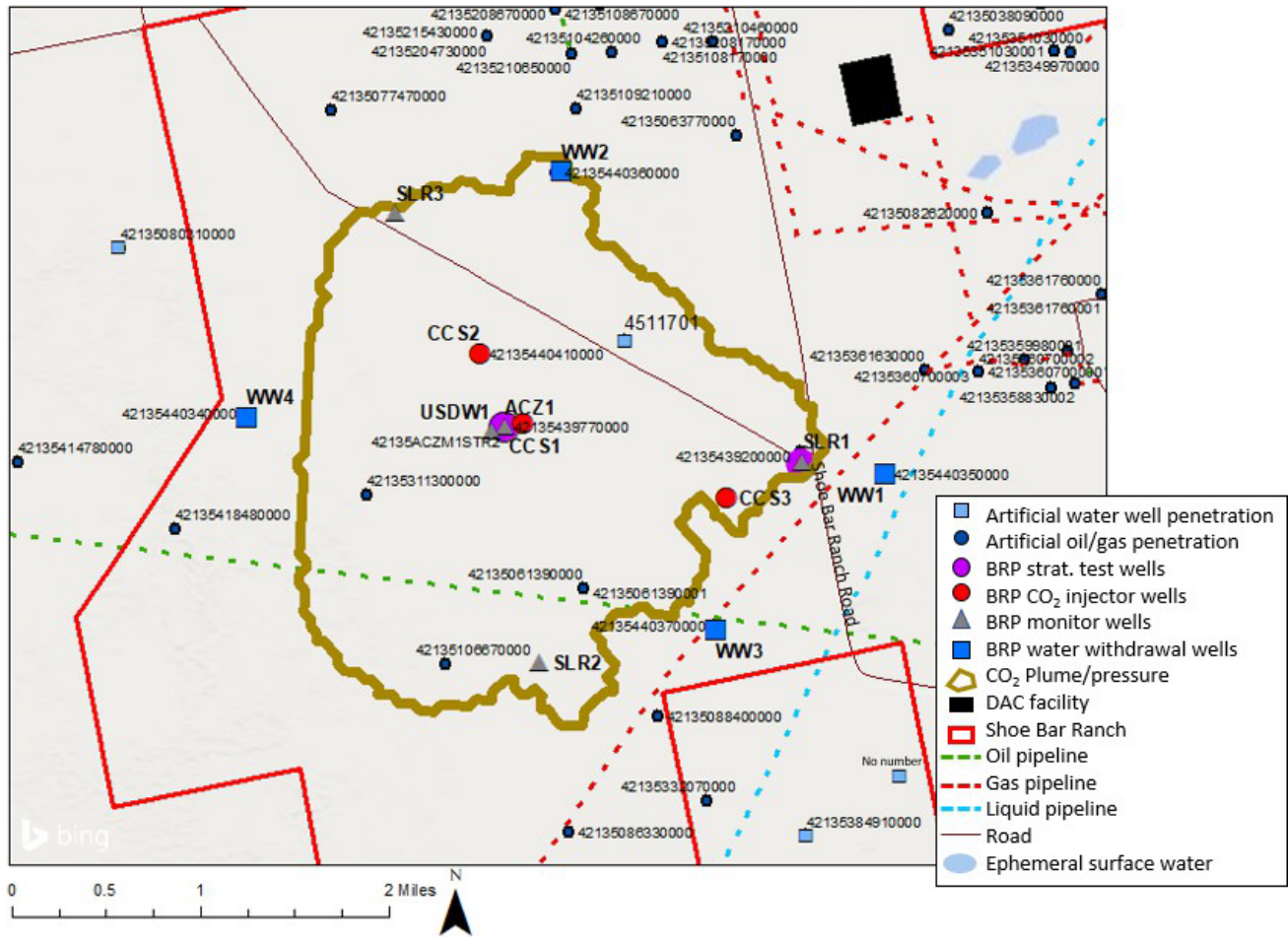

Figure 1—Overview of the BRP Project site AoR

For purposes of this application, the Project site encompasses the areas depicted in Figure 1 and 2 and include: (1) the AoR, (2) the Area of Interest (AoI), which is the area surrounding the AoR in the western half of the Shoe Bar Ranch (SBR) boundary; (3) the Shoe Bar Ranch (SBR), which is the surface land on which the Project is located; and (4) the simulation model outline that encompasses the area of SBR with an approximately one-mile buffer (Figure 2). The Project site includes the total extent of these four areas. The AoR in Figures 1 and 2 represents the combination of maximum extent of CO₂ plume at 50 years post-injection and the pressure plume at the stop of injection in January 2037.

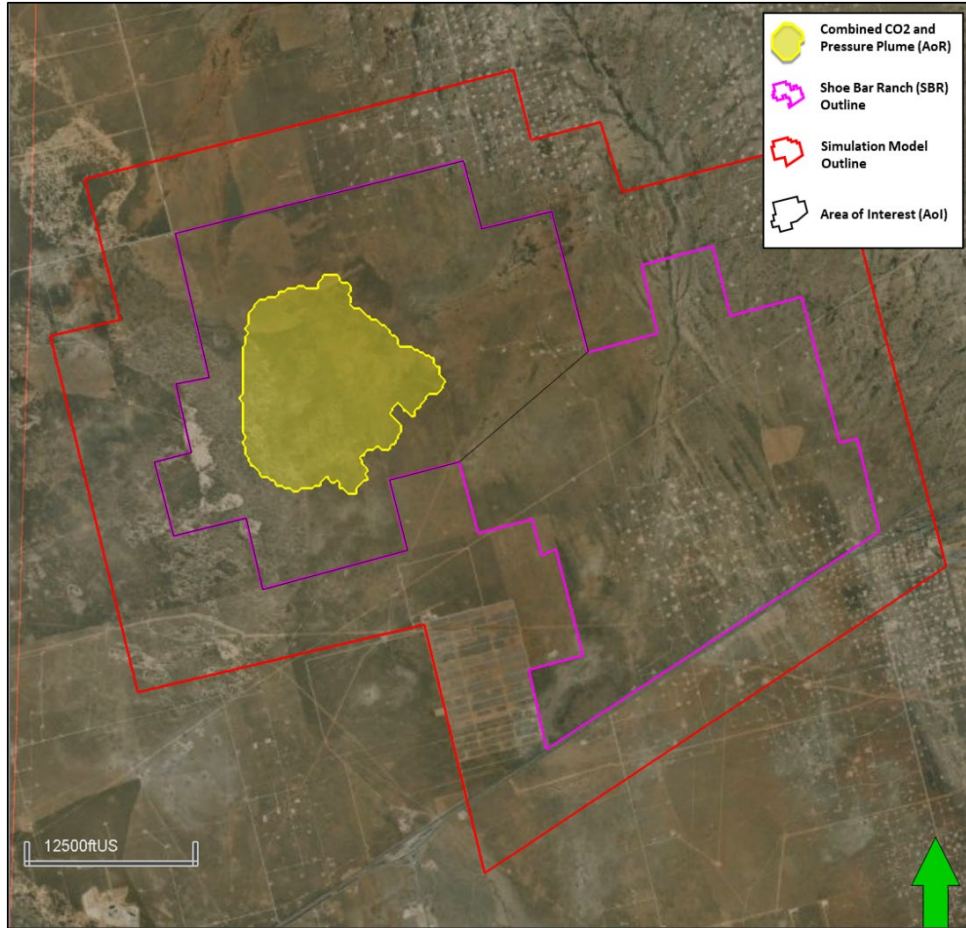

Figure 2—Definition of the outlines used in the Area of Review and Corrective Action Plan document.

2.2.3 Stratigraphy

2.2.3.1 Overview

The CO₂ storage complex in the proposed Project consists of four main elements:

1. Injection Zone (Lower San Andres Formation) with three sub-zones (G4, G1, Holt);
2. Upper Confining Zone (Upper San Andres and Grayburg Formations);
3. Regional Seal / Upper Confining System (Queen through Rustler Formations); and
4. Lower Confining Zone (Upper Glorieta Formation) (Figure 8).

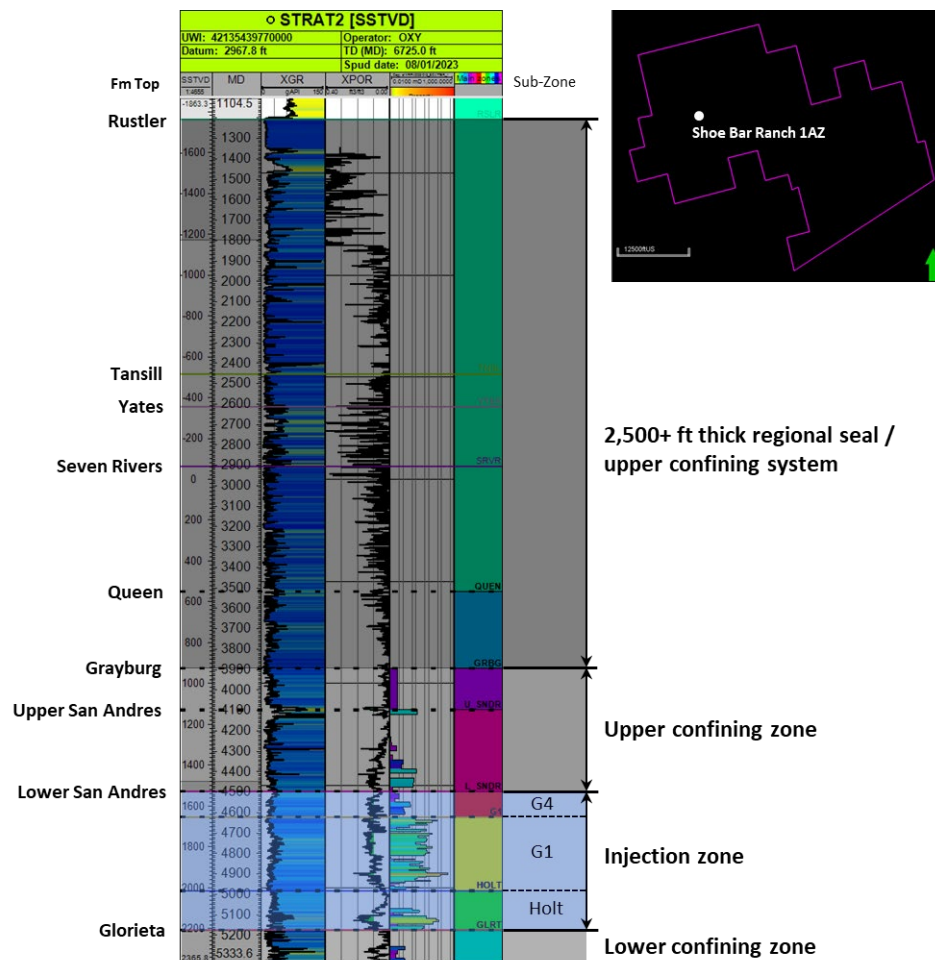

Figure 8—Stratigraphic column covering the Injection Zone, Upper Confining Zone, and Upper Confining System. UWI = Unique Well Identifier; SSTVD = True vertical depth subsea; MD = Measured depth; XGR = Gamma Ray log QCd by Oxy or OLCV petrophysicist; XPOR = porosity log QCd by Oxy or OLCV petrophysicist; K = Permeability

1.8 Initial Conditions

OLCV used MDT data obtained in the Shoe Bar 1 to determine the pre-injection pressure vs. depth. The model was initialized with a unit water saturation ($S_w = 1$), because the Lower San Andres Injection Zone is a saline aquifer. According to pyrolysis experiments conducted for the fluid samples acquired from Shoe Bar 1 (Appendix A Section 3.2), there is no evidence of hydrocarbons in the sequestration site. Water salinity measurements were obtained from water samples collected in the Shoe Bar 1. A brine sample representing the middle of the Injection Zone was used for the salinity value in the model. Additional details on data obtained from Shoe Bar 1 are presented in Section 2.3 of this document and in Appendix A.

Table 5—Initial Model Conditions

Parameter	Value or Range	Units	Depth (ft TVD)	Data Source
Temperature	96 to 98	°F	4,393 to 6,486	Measured
Pressure	Spatially varying	psi	4,393 to 6,486	Measured
Fluid density	69.03	lb/ft ³	4,769	Measured
Salinity	130,000	ppm	4,769	Measured
Formation compressibility	4.5E-6	1/psi		Analog San Andres reservoir

1.9 Operational Information

The simulation model forecast (CO₂ injection and water production) begins by using reservoir pressure data based on data acquired in the Shoe Bar 1 and Shoe Bar 1AZ wells. To delineate the BRP AoR, the simulation model considers the influence of the CO₂ injection and water production forecast from the BRP Aol. The simulation model assumes North Penwell Unit will operate at an injection/withdrawal ratio (IWR) of 1.0, and as a result, the waterflood will not influence reservoir pressure in the Aol.

One slant and one horizontal injector (BRP CCS1 and BRP CCS2 wells) will inject at a total maximum group rate of 1,058 MTPD between January 2025 to December 2026 (0.385 MMTPA). BRP CCS1 slant injector is completed in the upper porosity packages (sub-zone G1 and G4) of the Lower San Andres Formation (approximately 360 ft gross thickness in the G1 and 125 ft gross thickness in the G4) and the BRP CCS2 horizontal well is completed at the Holt sub-zone of the Lower San Andres (approximately 170 ft gross thickness).

A third slant injector, BRP CCS3, will commence injection in January 2027. The BRP CCS3, combined with BRP CCS1 and BRP CCS2, will be injecting at a total maximum group rate of 2,116 MTPD from January 2027 to January 2037 (0.772 MMTPA). BRP CCS3 slant injector is completed in the upper porosity packages of the Lower San Andres Formation (sub-zone G1 that is approximately 390 ft thick and G4 that is approximately 130 ft thick).

The slanted injectors have a secondary bottomhole injection pressure (BHIP) constraint of 2,625.3 psig that is set at a reference depth of 4,610 ft TVD. The BHIP for the horizontal well is 3,391.8 psig, and it is set at a reference depth of 5,115 ft TVD.

All wells continue injection until January 2037 when they are shut in. The simulation continues for another 50 years post-injection to simulate CO₂ migration after post-injection site closure.

To restrict the size of the pressure plume resulting from CO₂ injection, four water (brine) withdrawal wells will be drilled and perforated in the Lower San Andres Formation. These wells are planned to commence water withdrawal in July 2024. The minimum BHP of the producers is set at 485.3 psig at a reference depth of 4,610 ft TVD. Between July 2024 to December 2026, the wells produce at a total maximum group rate of 10,000 stb/day; and from January 2027 to January 2037, the wells produce at a total maximum group rate of 15,000 stb/day. The produced brine will primarily be used for Oxy's Enhanced Oil Recovery Operations (EOR) or other makeup water needs. Some of the brine may be injected into Class I disposal wells or utilized in desalination operations. Brine produced from the Project will not be injected into Class II Saltwater Disposal Wells (SWD).

Details of the planned injection and withdrawal wells are presented in Table 6.

Table 6—Operating Details for the Planned Injection and Withdrawal Operation

Operating Information	BRP CCS1	BRP CCS2	BRP CCS3	WW1	WW2	WW3	WW4
	Location (global coordinates, NAD27)						
Latitude	31.76479	31.76994	31.76031	31.76289	31.78419	31.75008	31.76384
Longitude	-102.7289	-102.7332	-102.7102	-102.6959	-102.7276	-102.7102	-102.7540
	Model coordinates (Texas State Plane, Central Zone, USft, NAD27)						
X	1255500	1254200	1261299	1265742	1256211	1261199	1247718
Y	771100	773000	769345	770190	778193	765626	770922
Perforated Interval (ft MD) *							
MD top	4,674	5,768	5,244	4,342	4,468	4,352	4,542
MD bottom	5,667	9,165	6,284	4,982	5,139	4,993	5,201
Wellbore diameter (in) *	6	6	6	6	6	6	6
Planned injection period	1-Jan-2025 to 1-Jan-2037						
Planned water production period	1-Jul-2024 to 1-Jan-2037						
Duration (years)	12	12	10	12.5	12.5	12.5	12.5
Group injection rate (MTPD)	1058 (January 2025 to December 2026) 2116 (January 2027 to January 2037)			-			
Daily average injection mass (MT/day)	450	1,112	450	-			
Daily maximum injection mass (MT/day)	600	1,500	600	-			
Total injection	1.83	4.87	1.77	-			

volume and mass (MMT)				
Maximum injection BHP (psig)	2,625.3	3,391.8	2,625.3	-
Average injection pressure (psig)	2,600.3	3,300	2,600.3	-
Group production rate (stb/D)	-			10,000 (July 2024 to December 2026) 15,000 (January 2027 to January 2037)
Minimum production BHP (psig)	-			485.3

*Represents measured depth (MD) along the deviated wellbores (not SSTVD) and diameter in the model, not final wellbore design.

4.2 AoR Delineation

4.2.1 Critical Pressure Front

The maximum differential pressure occurs at the time of maximum CO₂ cumulative injection in January 2037, because the wells are modeled to operate at a constant injection rate. Figure 74 shows the combined pressure at the time when injection ceases. Thus, the contour shown in Figure 74 represents the maximum extent of the pressure front found in the model.

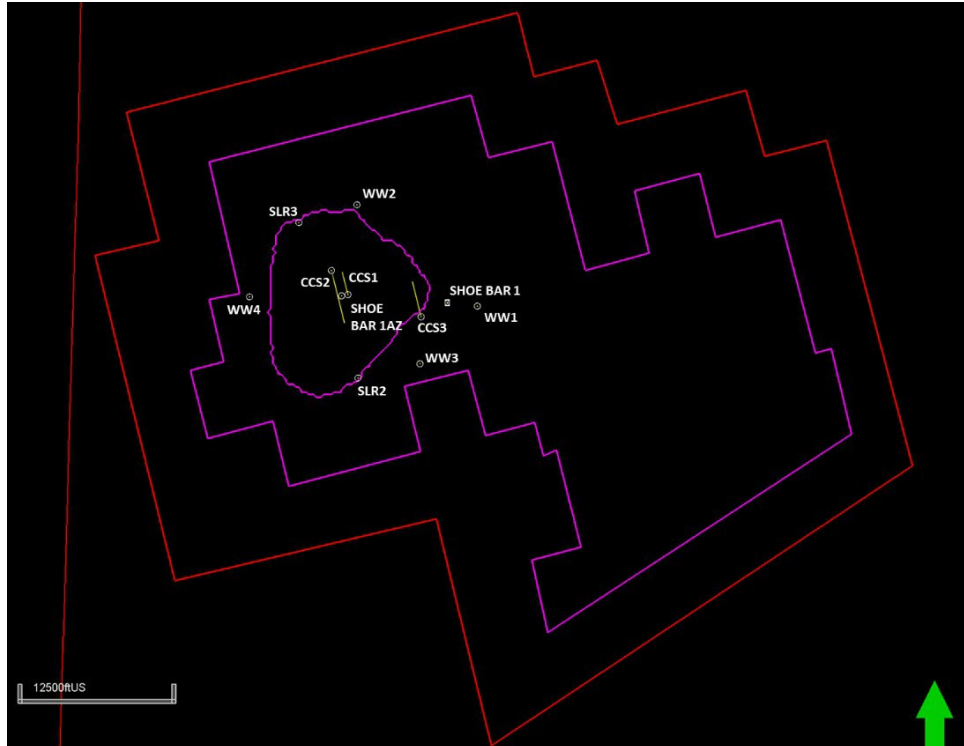

Figure 74—Maximum combined extent of pressure plumes for G4, G1, and Holt sub-zones at the end of injection in January 2037.

4.2.2 CO₂ Plume Extent

The CO₂ plume is shown as a projection of the global mole fraction of gas in the Injection Zone. The 3D property is first obtained by performing a cutoff of 0.1% to display the plume as any cells greater than the threshold value. Then the projection of all layers is performed in the map. The plume is within the boundaries of the brine producer wells. Figure 76 illustrates the CO₂ plume extent in 3D after injection ceases in January 2037, which is the maximum extent during simulation.

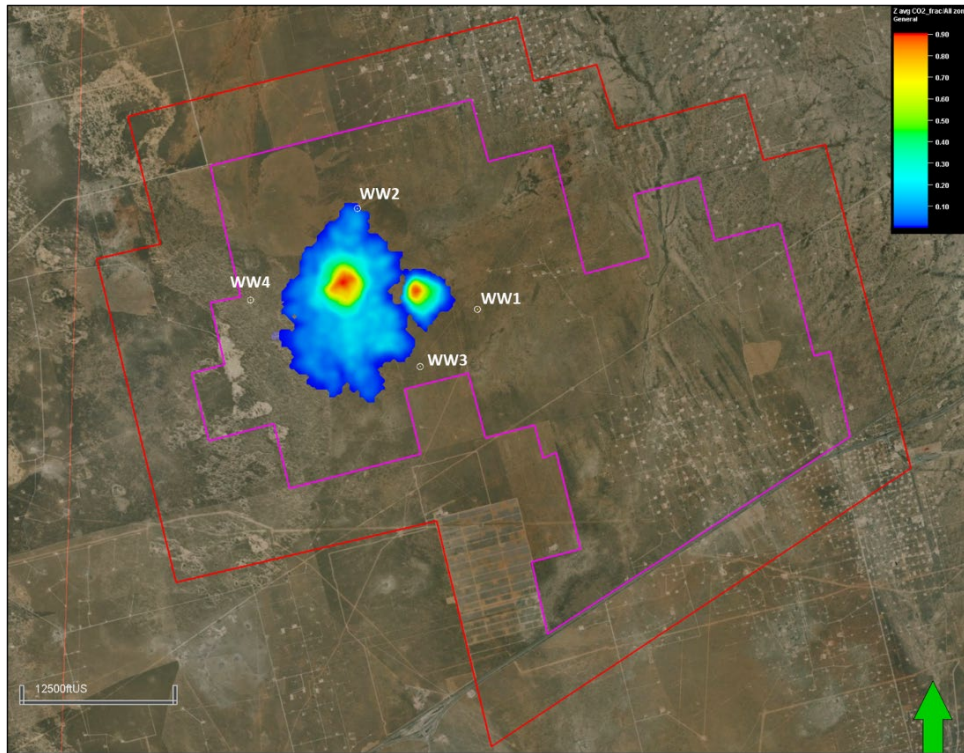

Figure 75—Areal extent of the vertically averaged maximum CO₂ plume extent at the end of injection in January 2037. Note that brine withdrawal in well WW2 occurs in the G4 and G1 sub-zones of the Lower San Andres and does not come in contact with 2D projection of the CO₂ plume extent projected from the Holt sub-zone (lower part of Lower San Andres).

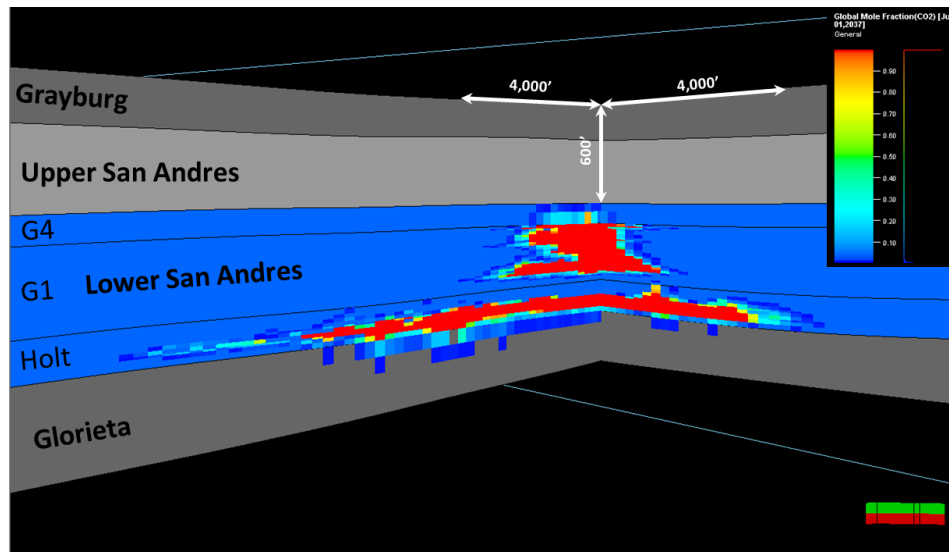

Figure 76—3D view of the maximum CO₂ plume extent, occurring at the end of injection in January 2037 (3X vertical exaggeration).

4.2.3 Final Area of Review

The final AoR (Figure 77) is the combination of the maximum pressure front (Figure 74) and the maximum CO₂ plume (Figure 75). The predicted evolution of the CO₂ plume and pressure front relative to the monitoring locations is shown in the Post-Injection Site Care (PISC) and Site Closure Plan document of this permit.

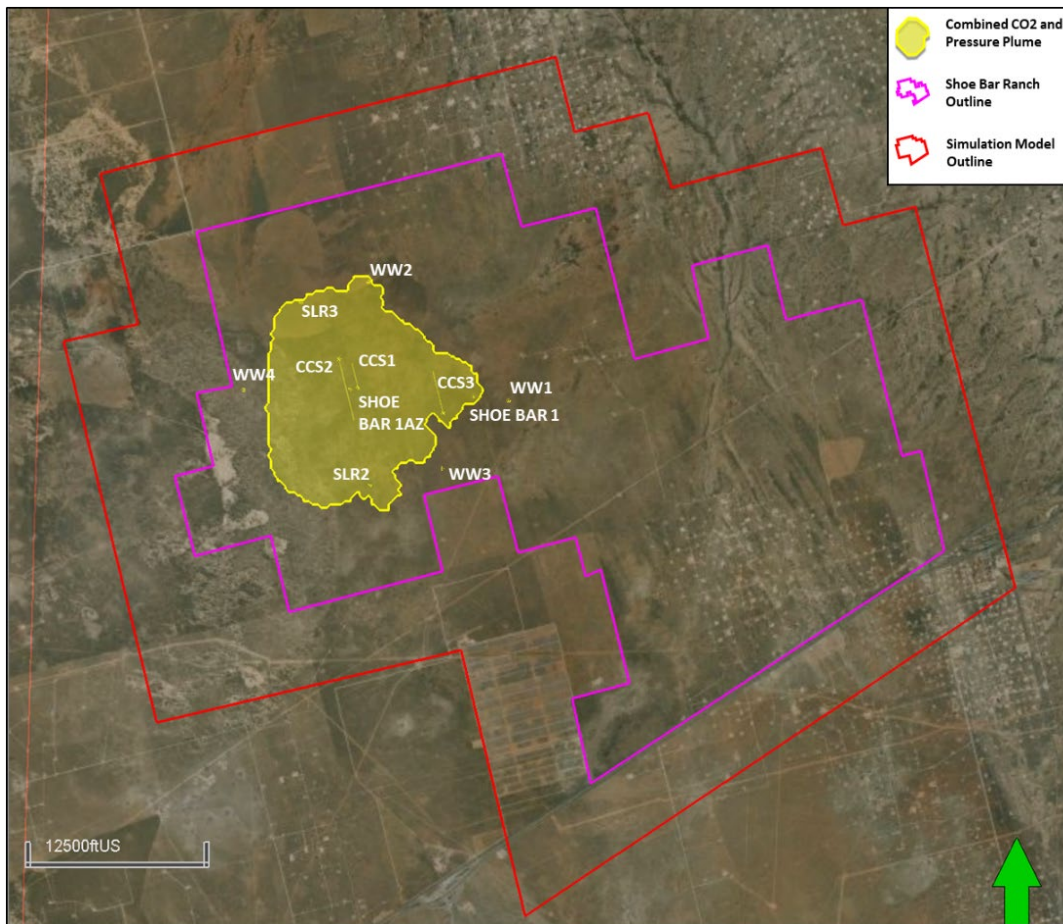

Figure 77—Combined AoR showing pressure and CO₂ plumes along with proposed injection wells (BRP CCS1-CCS3), stratigraphic wells (Shoe Bar 1 and Shoe Bar 1AZ), water withdrawal wells (WW1 - WW4), Injection Zone monitoring wells (SLR2 and SLR3), and Upper Confining Zone monitoring well (ACZ1).

5.0 Corrective Action

5.1 Tabulation of Wells Within the AoR

The BPR Project will utilize three CO₂ injection wells. The AoR represents the maximum extent of pressure from three wells at the end of 12 years of CO₂ injection and the maximum extent of the CO₂ plume 50 years after injection ceases. The AoR is modeled to be approximately 5.4 square miles.

OLCV conducted an airborne magnetic survey in May 2023 to identify and/or to confirm the location of existing artificial penetrations in the AoR. The data from this survey was analyzed and interpreted by Oxy and OLCV geophysicists. Magnetic anomalies were cross-referenced with aerial photos, drone photographic surveys, and physical site observation where necessary. See Appendix B for additional details on identifying APs.

In addition to airborne magnetic data, OLCV consulted the following databases to identify APs: TRRC, TCEQ, Texas Department of Licensing and Regulation (TDLR), Texas Water Development Board (TWDB), and the Texas Bureau of Economic Geology (BEG). Through this evaluation, OLCV identified two well locations that were incorrectly recorded in licensed databases such as IHS. OLCV cross-checked the recorded latitude and longitude with public well records, airborne magnetic survey, and drone imagery to confirm the appropriate well locations.

Excluding the wells drilled for the project: Shoe Bar 1, Shoe Bar 1AZ, Shoe Bar Ranch 1WW, Shoe Bar Ranch 2WW, Shoe Bar Ranch 3WW, Shoe Bar Ranch 4WW, and Shoe Bar USDW1; OLCV identified a total of four other APs in the AoR: three plugged wells related to oil and gas operations and one well used for USDW brine production. See Tables 16 and 17 below for tabulated well information. Additional information on all data sources consulted to identify AP is presented in Appendix B. OLCV will periodically re-evaluate the AoR and expand the tabulation of APs, as needed.

Table 16—Locations of existing wells in the AoR

					From public and licensed sources	
API or state well number	Well Name	Recorded Status	Drill Date	Abandon Date	Latitude NAD27	Longitude NAD27
4213543920	Shoe Bar 1	Stratigraphic test well	1/2/2023	NA	31.76343602	-102.7034981
4213543977	Shoe Bar 1AZ	Stratigraphic test well	7/29/2023	NA	31.76448869	-102.7305326
NA	Shoe Bar USDW1	Monitor	12/23/2023	NA	31.7641190	-102.7316750
4213544034	Shoe Bar Ranch 4WW	Water supply well	3/26/2024	NA	31.76384464	-102.7539505
4213544037	Shoe Bar Ranch 3WW	Water supply well	4/22/2024	NA	31.75008553	-102.7102206
4213544036	Shoe Bar Ranch 2WW	Water supply well	4/12/2024	NA	31.78419981	-102.7275869
4213544035	Shoe Bar Ranch 1WW	Water supply well	4/3/2024	NA	31.76289539	-102.6959232
4213506139	Eidson-Scharbauer-1	Dry hole, plugged	4/18/1958	9/21/1959	31.7526374	-102.7218925
4213510667	Scharbauer Eidson-1	Dry hole, plugged	12/23/1964	2/19/1965	31.7460090	-102.7343253
4213531130	Eidson E-1	Dry hole, plugged	8/1/1973	8/23/1973	31.7587481	-102.7431169
4511701	-	Brackish water producer; plugged	1940	9/20/2023	31.7719430	-102.7205540

5.1.1 Depth of the USDW in wells planned for corrective action

The Dockum is defined as the lowermost USDW in the AoR. The base of the USDW is picked on well log data from wells in the AoR with the exception of the Scharbauer Eidson-1 (API 4213510667) that does not have log data. The USDW was interpolated at this location based on well log correlation. See Appendix B for details on the depth of the USDW.

5.2 Corrective Action Plans and Schedule

5.2.1 Corrective Action Plan Overview

A detailed analysis was performed to evaluate the risk and timing of the plume and/or pressure front reaching each of the wells inside the AoR. The analysis was divided into two main categories to assess the risks and mitigations, based on the following possible mechanisms of failure:

- 1) **CO₂ plume corrosive effect and contamination of USDW aquifer.** The analysis focused on potential leakage paths from the Injection Zone that could endanger the USDW for those wells that are projected to be exposed to the CO₂ plume. The lack of proper isolation, cement degradation by carbonic acid, mechanical barrier failures, and micro-annulus or casing corrosion are some of the situations that increase the risk of brine or CO₂ leaks.
- 2) **Pressure front effect with brine contamination from deeper saline reservoirs to USDW aquifers.** This category includes wells that were not projected to be in contact with the CO₂ plume but are inside the simulated pressure front. In this scenario, the wells were evaluated for proper hydraulic isolation between the Injection Zone and the USDW. The degradation or corrosion of cement, tubulars, and tools is not considered a high-risk scenario in this category.

5.2.2 Modeled Extent of AoR

OLCV modeled the extent of the AoR to determine which APs required corrective action and the timing of the corrective action. OLCV will conduct corrective action on three heritage APs: Eidson-E-1 (API 4213531130), Scharbauer Eidson-1 (API 4213510667) and Eidson Scharbauer- 1 (API 4213506139) prior to commencement of CO₂ injection operations.

1) Simulation of three years of injection

During the first three years of injection (Figure 78), the simulated CO₂ plume does not reach any APs. However, the pressure front reaches the well **Eidson E-1** (API 4213531130) in the Holt sub-zone of the Lower San Andres in this time period. Corrective actions are proposed and will be executed prior to the commencement of injection operations. The monitoring network (as described in the Testing and Monitoring Plan document of this permit application) will be in place. Data gathering for pressure, temperature, and CO₂ saturation in the injectors and monitoring wells will be used to track pressure and CO₂ movement, calibrate the simulation model, and validate the AoR in the initial years of injection.

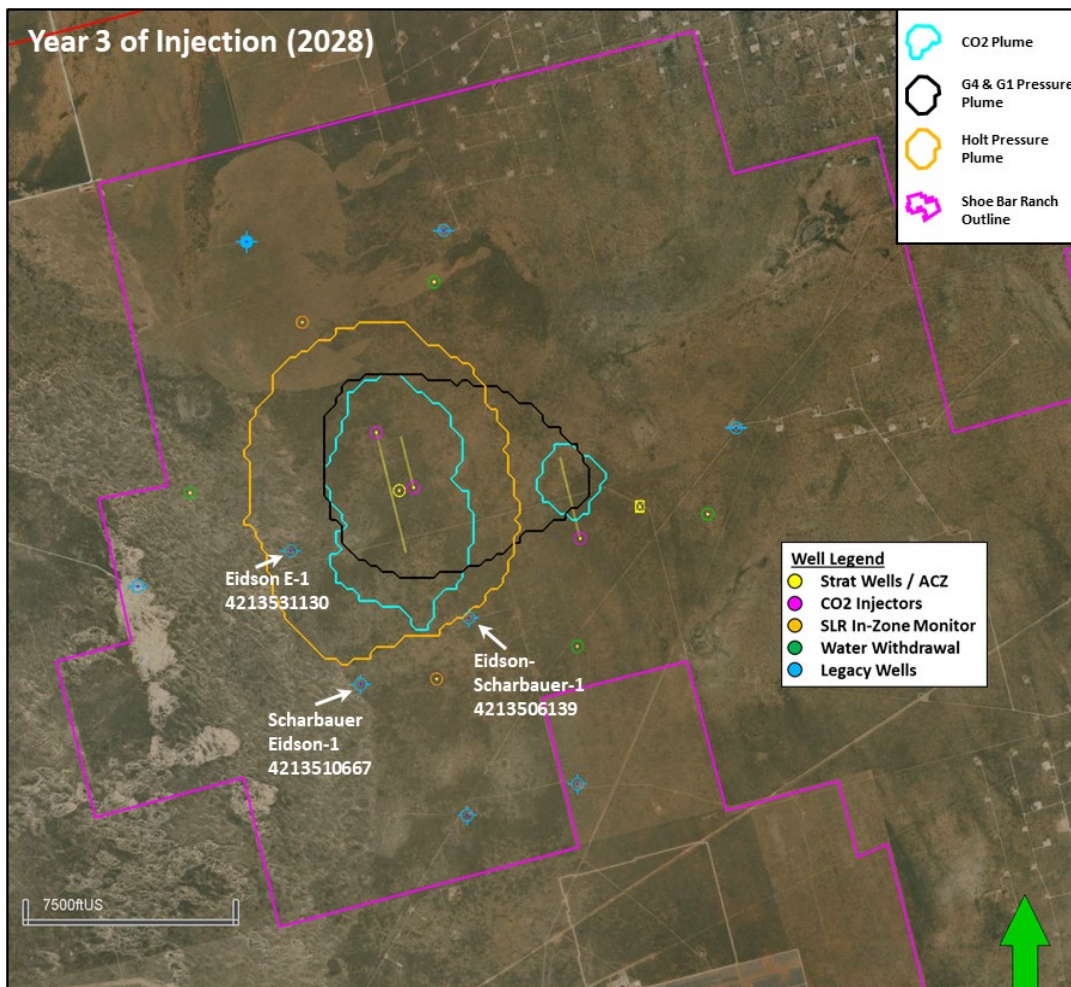

Figure 78—Three Years of injection, showing that the Holt sub-zone pressure plume reaches legacy well EIDSON E-1.

2) Simulation after five years of injection

From the second to fifth year of injection (Figure 79), the simulated CO₂ plume does not reach any APs. The pressure front reaches the **Eidson-Scharbauer-1** (API 4213506139) and **Scharbauer Eidson-1** (API 4213510667) at the Holt sub-zone of the Lower San Andres, as shown in Figure 79. Because OLCV will have already conducted corrective action on this AP, there is no expected impact to the USDW.

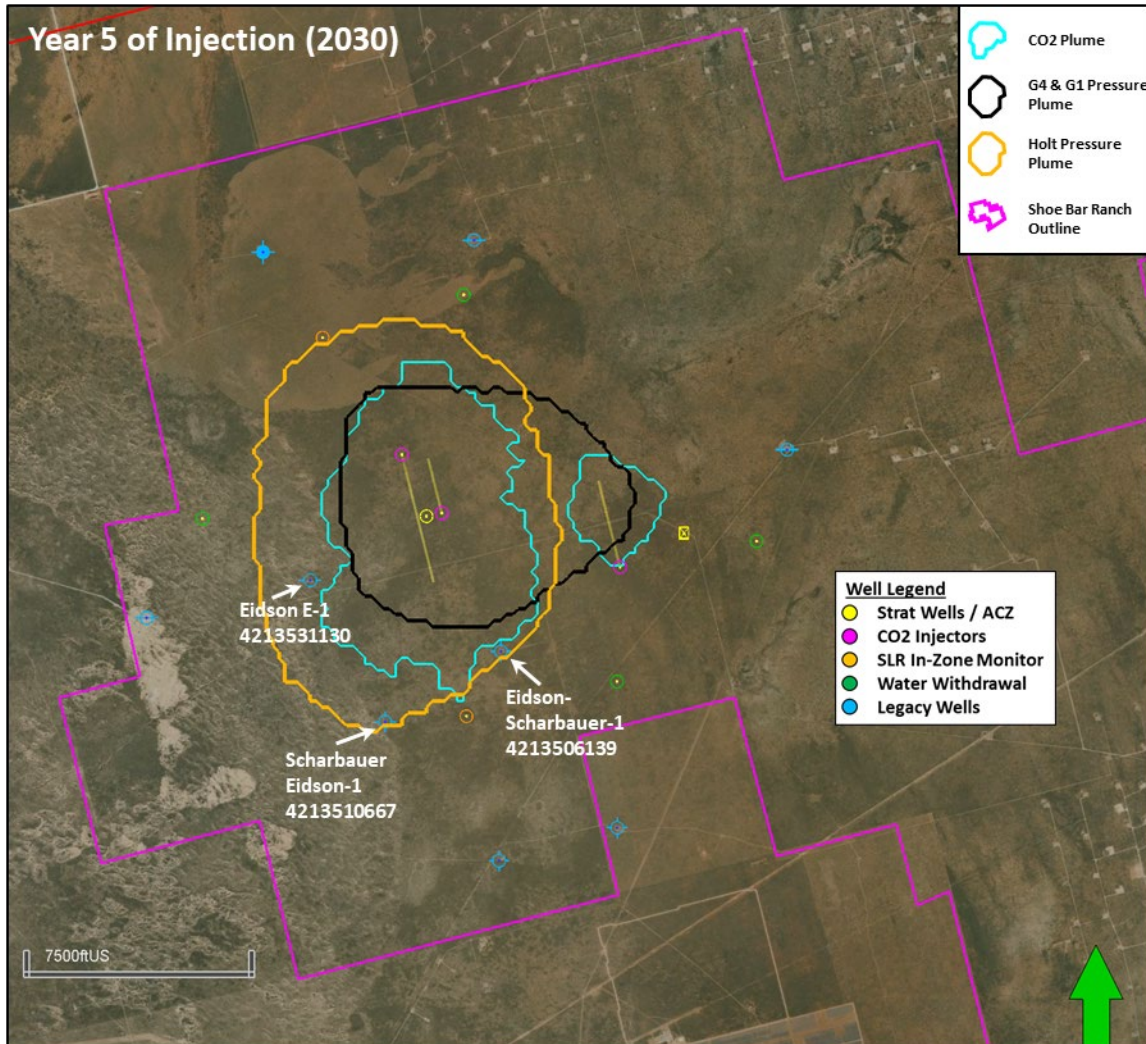

Figure 79—CO₂ plume and critical pressure front extent after 5 years of injection.

3) Simulation after seven years of injection

In the seventh year of injection, the simulated CO₂ plume reaches AP **Eidson-Scharbauer- 1** (API 4213506139), as shown in Figure 80. Because OLCV will have already conducted corrective action on this AP, there is no expected impact to the USDW.

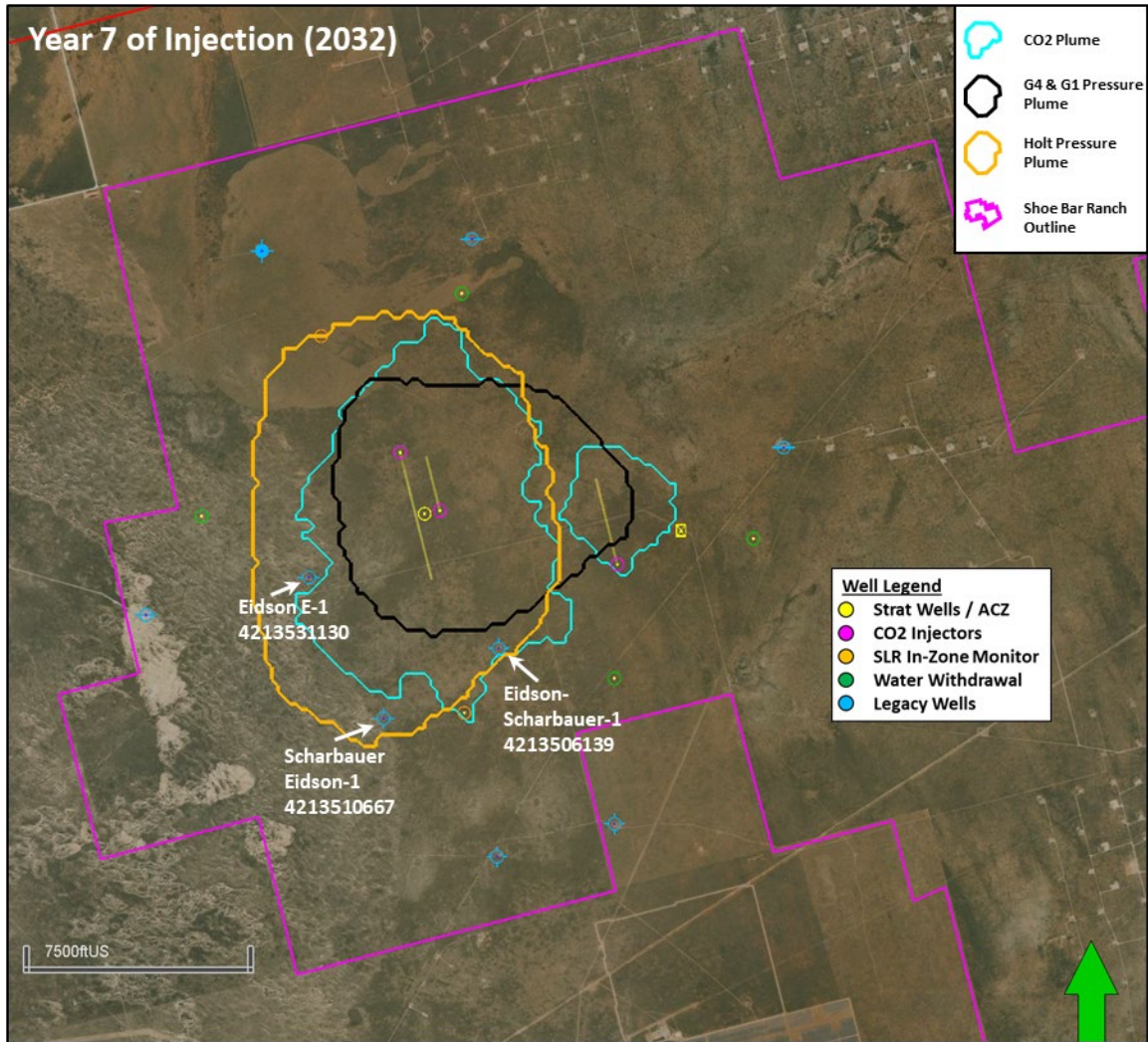

Figure 80—CO₂ plume and critical pressure front extent after 7 years of injection.

4) Simulation after 12 years of injection

By the twelfth year after the commencement of injection, the simulated CO₂ plume reaches APs **Scharbauer Eidson-1** (API 4213510667) and **Eidson E-1** (API 4213531130), as shown in Figure 81. The modeled CO₂ plume and critical pressure front reaches its maximum area and value when injection ceases. The size of the CO₂ and pressure plumes slightly shrink after the cessation of injection. Figure 82 shows the modeled CO₂ plume and critical pressure front extent 50 years after the end of injection. Because OLCV will have conducted corrective action on these APs by this time, the risk of leakage to the USDW is mitigated.

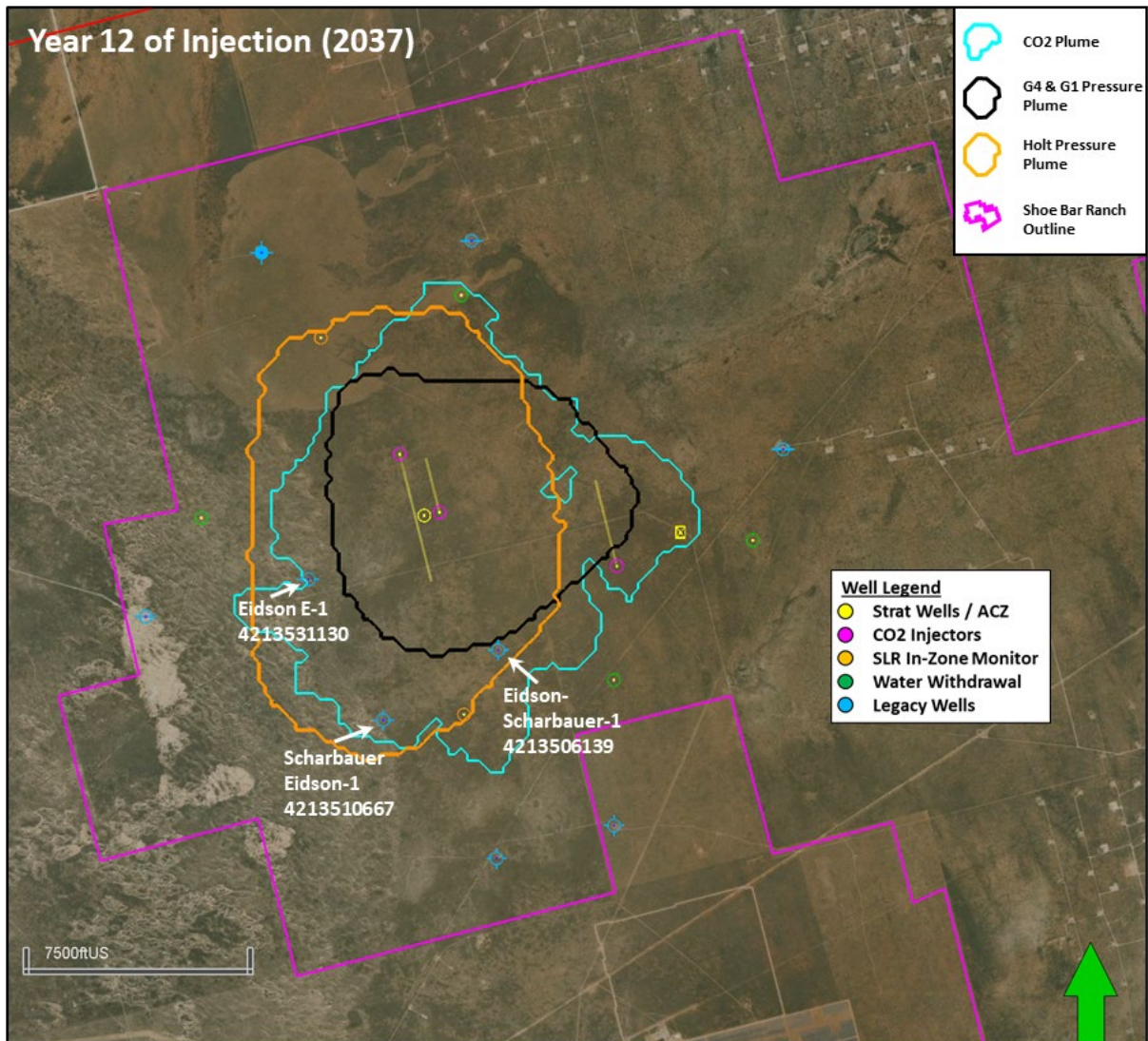

Figure 81—CO₂ plume and critical pressure front extent after 12 years of injection. Note that CO₂ plume reaches WW2 in map view but only in the Holt sub-zone and WW2 is a dedicated G4 and G1 sub-zone water withdrawal well.

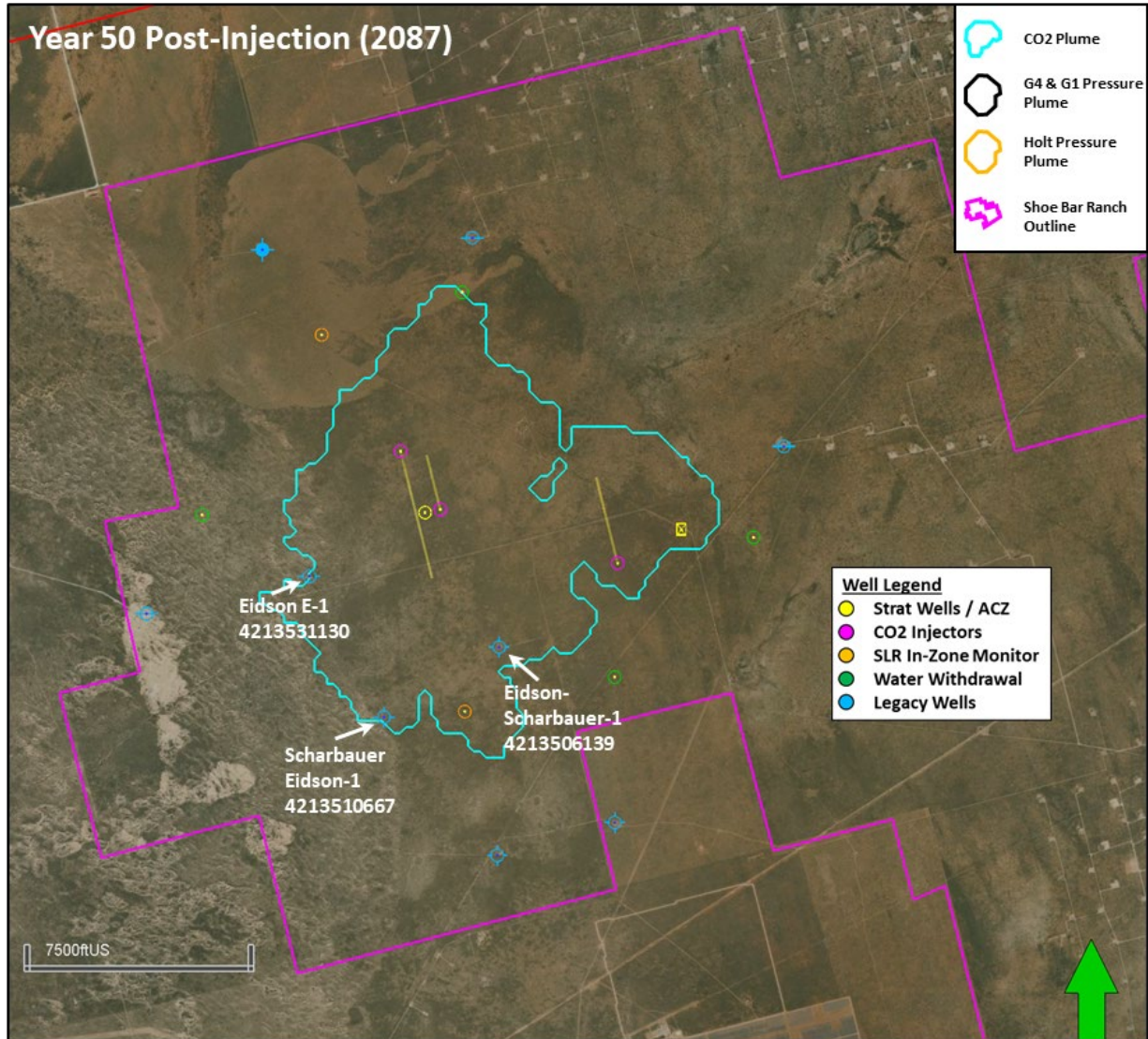

Figure 82—CO2 plume and critical pressure front extent 50 years after the end of injection. Note that pressure in the G1, G4 and Holt sub-zones has dissipated below the critical pressure by this point in time.

5.2.3 Timing of Corrective Action

The AoR defined by critical pressure is modeled to reach the Eidson E-1 (API 4213531130) within approximately two years following the commencement of CO₂ injection. This well will require corrective action. That action will be taken prior to the commencement of CO₂ injection operations.

The AoR defined by critical pressure is modeled to reach the Eidson-Scharbauer-1 (API 4213506139) and the Scharbauer Eidson-1 (API 4213510667) within approximately five years after the commencement of CO₂ injection. These wells will require corrective action. The corrective action will be performed prior to the commencement of CO₂ injection operations.

OLCV and a third-party water drilling contractor conducted a site investigation in July 2023 and determined that well 4511701 should be plugged and abandoned because of a shallow hole obstruction possibly due to casing corrosion or sanding event. The well was plugged and abandoned according to TCEQ standards in September 2023. No further remedial action is required on this well.

OLCV will evaluate Project data and re-evaluate the AoR on a regular basis, and at least every five years. OLCV will use data collected from injection and monitoring wells and indirect geophysical data to compare with predicted results from the dynamic simulation model. The model will be updated, if needed, to better match historical observations. If updated modeling work results in a re-delineation of the AoR, a revised corrective action plan and schedule will be completed pursuant to 40 CFR §146.84(d).

Corrective action plugging procedures for Eidson E-1 (API 4213531130), Eidson-Scharbauer-1 (API 4213506139), and the Scharbauer Eidson-1 (API 4213510667) are shown below. Please refer to Appendix A of the Plugging Plan for plugging procedures and diagrams for the other project wells currently constructed: USDW1, WW1, WW2, WW3, WW4, SLR1 and ACZ1 wells.

Table 17—Corrective action date for APs in AoR

API or state well number	Well Name	Planned actions	Date of corrective action and/or plugging
4511701	-	Remediation performed; plugged	2023
4213543920	Shoe Bar 1	Utilize as monitor during injection and post-injection periods before final plugging	2024 ¹ and ~10 years post Injection Period
4213543977	Shoe Bar 1AZ	Utilize as monitor during injection and post-injection periods before final plugging	2024 ¹ , ~10 years post Injection Period
4213506139	Eidson-Scharbauer-1	Remediate	2025, prior to Injection Period
4213510667	Scharbauer Eidson-1	Remediate	2025, prior to Injection Period
4213531130	Eidson E-1	Remediate	2025, prior to Injection Period
4213544035	Shoe Bar 1WW	Brine water withdrawal	End of Injection Period
4213544036	Shoe Bar 2WW	Brine water withdrawal	After ~seven years of injection ² End of Injection Period
4213544037	Shoe Bar 3WW	Brine water withdrawal	End of Injection Period
4213544034	Shoe Bar 4WW	Brine water withdrawal	End of Injection Period
NA	Shoe Bar 1USDW	USDW monitor	~20 years post Injection Period

¹Plugging to convert stratigraphic test well into a monitoring well

²Plugging of the Holt sub-zone

6.0 Re-Evaluation Schedule and Criteria

6.1 AoR Re-Evaluation Cycle

OLCV will re-evaluate the AoR every five years during the injection and post-injection phases. In addition, monitoring and operational data will be reviewed periodically by OLCV during the injection and post-injection phases.

Activities to be performed during re-evaluation include:

- Review and analyze available monitoring and operational data and compare these data to the dynamic simulation forecast to assess whether the predicted CO₂ plume migration is consistent with the observed data. OLCV will incorporate direct monitoring data from injector wells, reservoir-level monitoring well, above confining zone monitoring wells and USDW-level monitoring wells. In addition, OLCV will incorporate data from indirect geophysical monitoring. Data collection is described in the Testing and Monitoring Plan and PISC Plan that are included as part of this application. Specific steps of this review and analysis include:
 - (1) Review available data on the position of the CO₂ plume and pressure front, such as pressure and temperature monitoring data, Pulsed Neutron logs (PNL), fluid samples, DInSAR, and repeat Vertical Seismic Profile and/or 2D seismic data.
 - Correlate the time-lapse PNL and time-lapse VSP/2D data to locate and track the movement of the CO₂ plume. A good correlation between the two data sets will provide confidence in the model's ability to represent the storage complex.
 - (2) Review downhole reservoir pressure data collected from various locations and intervals using a combination of surface and downhole pressure gauges.
 - (3) Review water chemistry monitoring data collected in SLR wells and in the ACZ monitoring wells, verifying that there is no evidence of CO₂ or brines that represent an endangerment to any USDWs.
 - (4) Review operating data, e.g., injection rates and pressures, and verify they are consistent with the inputs used in the most recent modeling effort.
 - (5) Review geologic data acquired since the last modeling effort, e.g., additional site characterization performed or updates of petrophysical properties from core analysis. Identify whether new data are materially different from the modeling inputs and assumptions.
- Compare the results of computational modeling used for AoR delineation to the monitoring data

collected. Monitoring data will be used to show that the computational model accurately represents the storage site and can be used as a proxy to determine the plume's properties and size. The degree of accuracy is demonstrated by comparing monitoring data with the model's predicted properties (i.e., plume location, rate of movement, and pressure decay). Statistical methods will be employed to correlate the data and confirm the model's ability to represent the storage site accurately.

- If the current data are consistent with model inputs and/or if the model forecast is unchanged after incorporation of these data, no update to the AoR will be needed. In this case, a report including data and results will be prepared to demonstrate that no re-delineation of the AoR is needed.
- If material changes in site conditions or operating parameters have occurred, or if data indicate that the actual plume or pressure front may extend beyond the modeled plume and pressure front, the AoR will be re-delineated. Steps to re-delineate the AoR include:
 - (1) Revise the site conceptual model based on the new site characterization, operational, or monitoring data.
 - (2) Calibrate and history-match the model to minimize the differences between monitoring data and model simulations.
- Perform the AoR delineation phased approach as described in Section 4.0 AoR Delineation of this document. Review legacy AP within the AoR and perform corrective action on wells, if needed. Specific steps include:
 - (1) Identify any wells that fall within the AoR. Evaluate the status and records for wells that not previously evaluated and provide a description of each well's type, construction, date drilled, location, depth, and record of plugging and/or completion.
 - (2) Determine which wells in the newly delineated AoR are plugged in a manner that prevents movement of carbon dioxide or other fluids that may endanger USDWs.
 - (3) Perform corrective action on all deficient wells in the AoR using methods designed to prevent the movement of fluid into or between USDWs, including the use of materials compatible with carbon dioxide.
- Prepare a report documenting the AoR re-evaluation process, data evaluated, any corrective actions determined to be necessary, and status of corrective action or a schedule for any corrective actions to be performed. The report will be submitted to EPA within 90 days of the re-evaluation and will include maps that highlight similarities and differences with previous AoR delineations.

- Update the AoR and Corrective Action Plan to reflect the revised AoR, along with other related Project plans, as needed.

6.2 Conditions Warranting an AoR Re-Evaluation Prior to Scheduled Re-Evaluation

Unscheduled re-evaluation of the AoR will be based on quantitative changes observed in monitoring wells, including unexpected changes in the following parameters: pressure, temperature, RST/PNL, or fluid chemistry changes in deep groundwater (>3,800 ft). Changes in these parameters may indicate that the actual plume or pressure front may extend beyond the modeled plume and pressure front. These changes might include:

- **Pressure:** Changes in pressure that are unexpected and outside three standard deviations from the average will trigger a new evaluation of the AoR.
- **Temperature:** Changes in temperature that are unexpected and outside three standard deviations from the average will trigger a new evaluation of the AoR.
- **RST Saturation:** Increases in CO₂ saturation that indicate the movement of CO₂ into or above the Confining Zone will trigger a new evaluation of the AoR unless the changes are found to be related to well integrity. Any identified well integrity issues will be investigated and addressed. Increases in CO₂ saturation in monitoring wells may indicate an early breakthrough of the CO₂ plume.
- **Deep Groundwater Constituent Concentrations:** Unexpected changes in fluid constituent concentrations that indicate movement of CO₂ or brine into or above the Confining Zone will trigger a new evaluation of the AoR unless the changes are found to be related to wellbore integrity. Any identified well integrity issues will be investigated and addressed.
- **Exceeding Fracture Pressure Conditions:** Pressure in any of the injection or monitoring wells exceeding 90% of the geologic formation fracture pressure at the point of measurement will trigger a new evaluation of the AoR.
- **Compromise in Injection Well Mechanical Integrity:** A significant change in annular pressure for the injection well that indicates a loss of mechanical integrity or a failed mechanical integrity test (MIT) in an injector will trigger a new evaluation of the AoR.
- **Induced Seismicity Monitoring:** Seismic monitoring data that indicate reactivation of a fault or structures due to pressurization of the reservoir as a consequence of the CO₂ injection will trigger a new evaluation of the AoR. The Project will review the monitoring data to discard naturally occurring events not related to the injection.

An unscheduled AoR re-evaluation may be needed if it is likely that the actual plume or pressure front may extend beyond what was modeled because any of the following has occurred:

- Seismic event greater than ML 3.5 within 5.6 miles of the injection well.
- Exceedance of any Class VI operating permit condition (e.g., exceeding the permitted volumes of carbon dioxide injected); or
- New site characterization data that change the computational model to such an extent that the predicted plume or pressure front extends vertically or horizontally beyond the predicted AoR.

OLCV will discuss any such events with the UIC Program Director to determine if an AoR re-evaluation is required. If an unscheduled re-evaluation is triggered, OLCV will perform the steps described in 6.1 AoR Re-Evaluation Cycle.

ATTACHMENT 3: FINANCIAL RESPONSIBILITY DEMONSTRATION

Facility Information

Facility name: Brown Pelican CO2 Sequestration Project
BRP CCS1, CCS2, and CCS3 wells

Well location: Penwell, TX

BRP CCS1	31.76479314	-102.7289311
BRP CCS2	31.76993805	-102.7332448
BRP CCS3	31.76031163	-102.7101566

1.0 Activities Requiring Financial Assurance

Pursuant to 40 CFR 146.85, OLCV, is required to demonstrate financial ability to successfully complete all the tasks associated with performing corrective action, plugging injection and monitoring wells, post-injection site care, site closure, and implementation of an emergency remedial response plan as specified in Table 1.

Table 1—List of Project activities that require Financial Assurance

Activity	Period of Performance
Performing corrective action	As needed
Plugging injection and monitoring wells	One time
Post-injection site care	Throughout the post-injection phase
Site closure	One time
Emergency/remedial response	As needed

2.0 Instruments to Meet Financial Responsibility

OLCV has reviewed the extensive guidance, research, and analysis documents published by the EPA and proposes to utilize a letter of credit to demonstrate financial responsibility for all activities requiring financial assurance. The letter of credit will be issued by [REDACTED] that has (a) assets of at least Ten Billion Dollars (\$10,000,000,000) and (b) has a Long-Term Credit Rating of at least “A-” by S&P and at least “A3” by Moody’s. The letter of credit will require the issuing institution to provide notice if it does not plan to reissue the letter of credit and will include a provision for automatic renewal. OLCV will establish a standby trust fund in accordance with EPA’s guidance to receive any funding necessary to address the cost of covered activities. OLCV may change the instrument(s) used to demonstrate financial assurance in accordance with 40 CFR 146.85.

3.0 Cost Estimate for Activities Covered by Financial Responsibility

In accordance with 40 CFR 146.85 et seq. and 16 TAC 5.205 (c)(2)(C)(i), the cost estimates must be performed for each phase separately and must be based on the costs to the regulatory agency of hiring a third party to perform the required activities.

For future activities related to plugging injection wells, post injection site care, and site closure, OLCV applied a discounted rate of 2.341 percent to discount those future cost estimates to today's dollars. The discount rate was calculated using a 15-year historical average of the Consumer Price Index for All Urban Consumers (CPI-U).

OLCV will provide financial assurance sufficient to cover the costs identified in Table 2. Costs are in 2024 \$USD. A detailed cost estimate is included as a separate document PBI_FA_BRP_COST_EST_V3_2024.pdf.

Table 2—Cost Estimate for Activities Covered by Financial Assurance

Activity	Cost (Millions of \$USD); Discounted
Performing corrective action	1.57
Plugging injection wells	0.41
Post-injection site care	5.96
Site closure	2.05
Emergency/remedial response	2.06

3.1 Performing Corrective Action

Three wells within the Area of Review (AoR) were determined to require corrective action. OLCV will conduct corrective action on: Eidson-E-1 (API 4213531130), Scharbauer Eidson-1 (API 4213510667) and Eidson Scharbauer-1 (API 4213506139) prior to commencement of CO₂ injection operations. Details of the corrective action plan are found in Section 5 of the Area of Review and Corrective Action Plan documents of this permit application.

3.2 Plugging Injection Wells

Details of the well plugging plan are found in the Plugging Plan document of this permit application.

3.3 Post-Injection Site Care

Details of the post-injection site care plan are found in the Post Injection Site Care and Site Closure Plan document

of this permit application. Post-injection site care costs were estimated from cessation of injection to site closure and account for seismic studies at five-year intervals, maintenance of the wells until closure, and monitoring the site to ensure protection of the USDW. Site closure costs include plugging monitoring wells, removal of surface facilities, and reclamation of the site.

3.4 Site Closure

Details of the site closure plan are found in the Post Injection Site Care and Site Closure Plan document of this permit application.

Surface infrastructure removal and restoration scope is included in the Site Closure and includes such items as:

- CO₂ pipeline abandonment and right-of-way restoration
- Water pipeline abandonment and right-of-way restoration
- Removal of pipeline valve stations
- Removal of surface facilities including pig traps, meters, monitors, etc.
- Restoration of well pads
- Removal of electrical infrastructure such as de-commissioned powerlines and communications panels

3.5 Emergency and Remedial Response

Details of the emergency and remedial response plan are found in the Emergency and Remedial Response plan document of this permit application.

Explanation of Cost Estimates

The instrument values included in this document are based upon cost estimates by the BRP Project team with input cost data from third party service providers. Cost estimates were provided during the permit application process. If the cost estimates change during the permitting process or the life of the Project, OLCV will adjust the value of the financial instruments.

The BRP Project uses a Carbon Capture and Storage stochastic Monte Carlo model that has been tailored to reflect site-specific factors for emergency and remedial response actions. This estimation approach is consistent with the U.S. EPA's Underground Injection Control (UIC) Program's Class VI regulatory requirements and is intended to inform the face value of financial assurances for the Brown Pelican site. The estimation method is based on the peer-reviewed approach developed by the BRP Project's third-party consultants and has been used to inform estimation of coverage amounts for emergency and remedial response in previously

approved Class VI permits. Specifically, the model's input parameters reflect the geologic location and specific chemical composition of the Project's CO₂ injectate stream, as well as site-specific conditions that exist within the established area of review. The analysis adopts several conservative input assumptions and incorporates probabilistic calculations that allow for multiple release incidents across geologic sequestration activities – from injection through post-injection site care to site closure. The resulting coverage values are based on generally accepted response actions commonly used to respond to contamination incidents that could impair the public's ability to safely access Underground Source(s) of Drinking Water (USDWs).

A model run of 50,000 Monte Carlo trials yields an upper-bound coverage estimate to satisfy emergency and remedial response of approximately \$2.06 million in current 2024 dollars. This upper-bound estimate reflects the single Monte Carlo trial with the greatest estimate of emergency and remedial response costs out of the 50,000 trials run (comprising four separate ERR actions over the 62-year combined duration of injection and post-injection site care periods). The estimates specifically account for an array of possible risk events of potential concern at CCS sites, including undocumented deep well leaks, CO₂ injection well leaks, CO₂ monitoring well leaks, rapid leakage through the caprock, slow leakage through the caprock, releases through an existing fault, releases through an induced fault, leakage through caprock/faults then a shallow well and pipeline release events. These estimates are reasonable and appropriately conservative, in keeping with the recommendations set forth in EPA's financial assurance guidance for Class VI wells.

ATTACHMENT 4: CONSTRUCTION DETAILS

Facility name: Brown Pelican CO2 Sequestration Project
BRP CCS1, CCS2, and CCS3 wells

Well location: Penwell, TX

BRP CCS1	31.76479314	-102.7289311
BRP CCS2	31.76993805	-102.7332448
BRP CCS3	31.76031163	-102.7101566

1.0 Overview

Oxy Low Carbon Ventures, LLC (OLCV) will construct CO₂ injection wells for the Brown Pelican CO₂ Sequestration Project (BRP Project or Project) according to the procedures in this document. The matter of construction details is relevant to the requirements of Environmental Protection Agency (EPA) document 40 CFR Subpart H – Criteria and Standards Applicable to Class VI Wells. The main topics covered in this attachment are special construction requirements, open hole diameters and intervals, casing specifications, tubing specifications, data acquisition and testing plan, and demonstration of mechanical integrity.

The Brown Pelican CCS1, CCS2 and CCS3 (BRP CCS1, BRP CCS2 and BRP CCS3) injection wells are designed with the highest standards and best practices for drilling and well construction. The design parameters and material selection are aimed to ensure mechanical integrity in the system and to optimize the operation during the life of the Project.

2.0 Design Parameters and Specifications

The well was designed to maximize the rate of injection while maintaining the bottomhole pressure below 90% of the fracture gradient. The selected design provides enough clearance to deploy the pressure and temperature gauges on tubing and install a fiber optic cable on the long string casing to ensure continuous surveillance of external integrity and conformance.

Design parameters that will be employed during the life of the well are shown in Table 1, and CO₂ specifications for the Project are shown in Table 2. A nodal analysis was used to perform sensitivities on the tubing size, rate of erosion, and potential movement of the tubulars. The nodal analysis results, operating parameters, and CO₂ specifications were used in selecting materials to be used to construct the well.

Table 1—Design Parameters

Parameter	Value or Range
Injection rate (MTPD)	417-1319
Tubing pressure (psi)	1,000 to 1,800
Annular surface pressure (psi)	0 to 400
Surface temperature (°F)	60 to 90
Bottomhole temperature (°F)	120

Note:

Annular surface pressure between the tubing and long string will be kept between 0 and 400 psi to monitor changes during injection. It is not recommended to apply the maximum injection pressure to the annulus between the tubing and the long string casing to avoid unnecessary stress on the cement sheath, which could lead to a micro-annulus or microfractures.

Table 2—Specification of CO2 Injectate

Component	Specification
CO2 content	>95 mol%
Water	<30 lbm/MMscf
Nitrogen	<4 mol%
Sulphur	<35 ppm by weight
Oxygen	<5 mol%
Glycol	<0.3 gal/MMscf
Carbon Monoxide	<4,250 ppm by weight
NOx	<6 ppm by weight
SOx	<1 ppm by weight
Particulates (CaCO3)	<1 ppm by weight
Argon	<1 mol%
Surface pressure	>1,600 psig
Surface temperature	>65°F and <120°F

3.0 Well Design

OLCV plans to construct three CO₂ injector wells: BRP CCS1, BRP CCS2, and BRP CCS3 for the Project. The locations and orientations of those wells are shown in Figure 1 below.

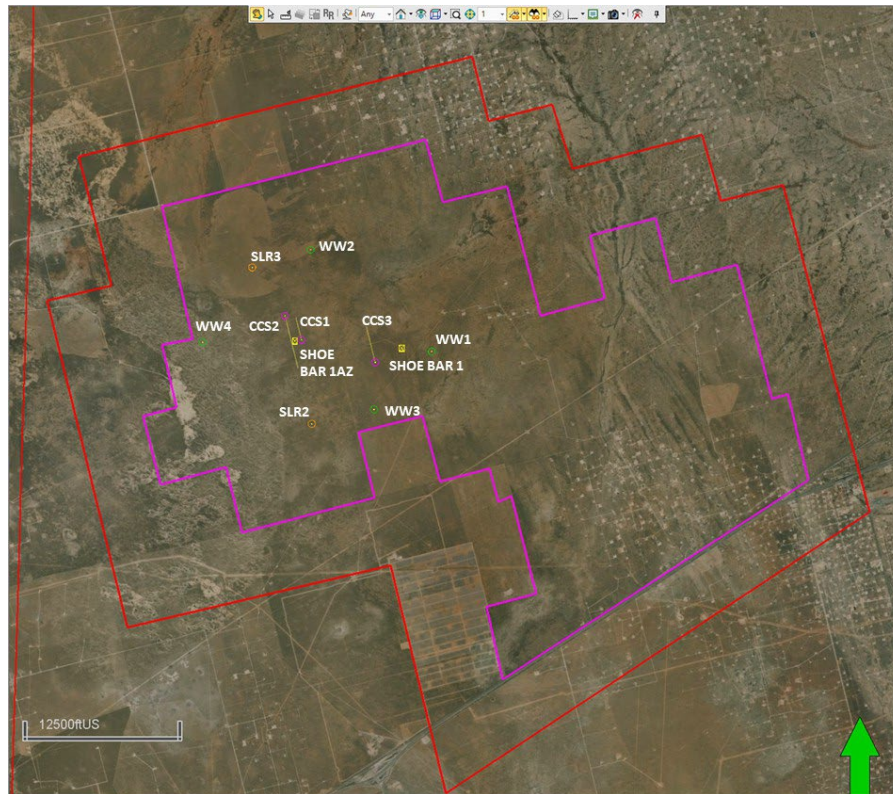

Figure 1—BRP CCS1, BRP CCS2 and BRP CCS3 Well Locations

3.1 BRP CCS1

3.1.1 Design for BRP CCS1

The BRP CCS1 well design includes three main casing sections: 1) surface casing to cover the USDW and provide integrity while drilling to the Injection Zone, 2) intermediate section, and 3) a long string section to acquire formation data and isolate the target formation while running the upper completion equipment. Figure 2 presents wellbore trajectory of BRP CCS1 and Figure 3 is BRP CCS1 well proposed schematic.

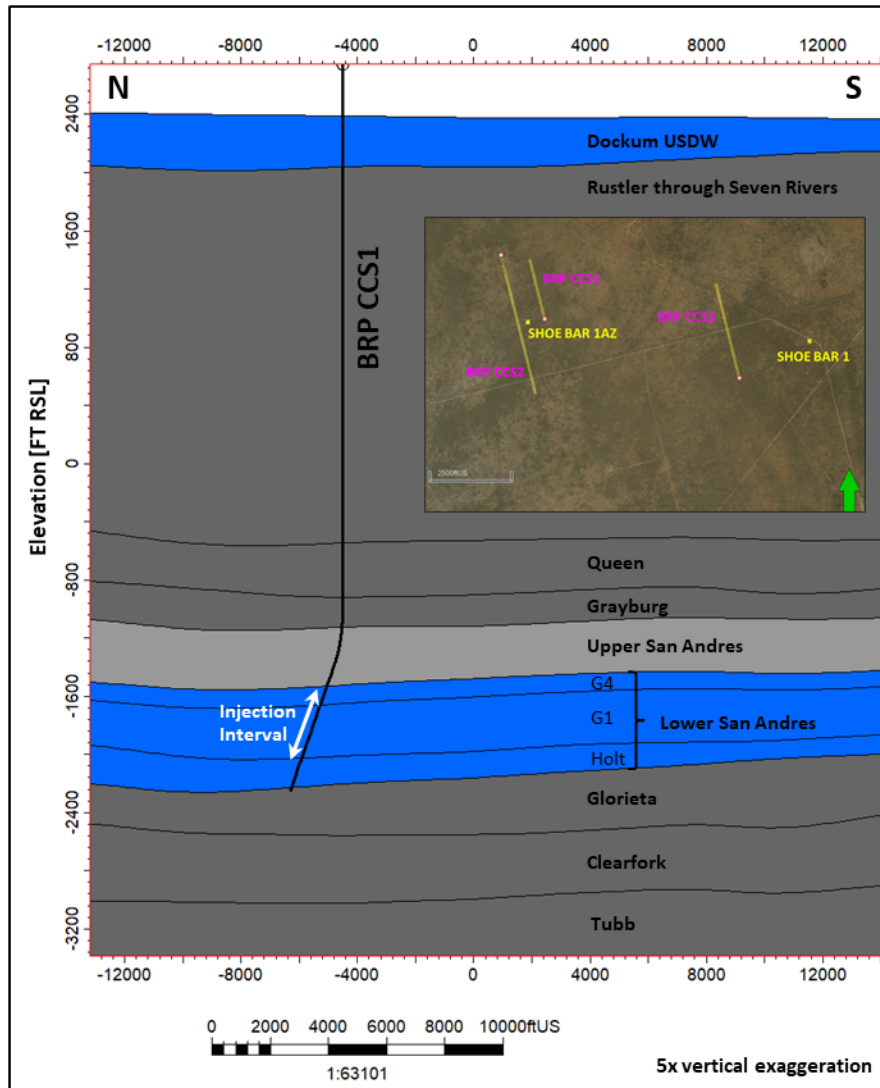

Figure 2—Wellbore trajectory of BRP CCS1 with completion interval in sub-zone G4-G1 highlighted in white.

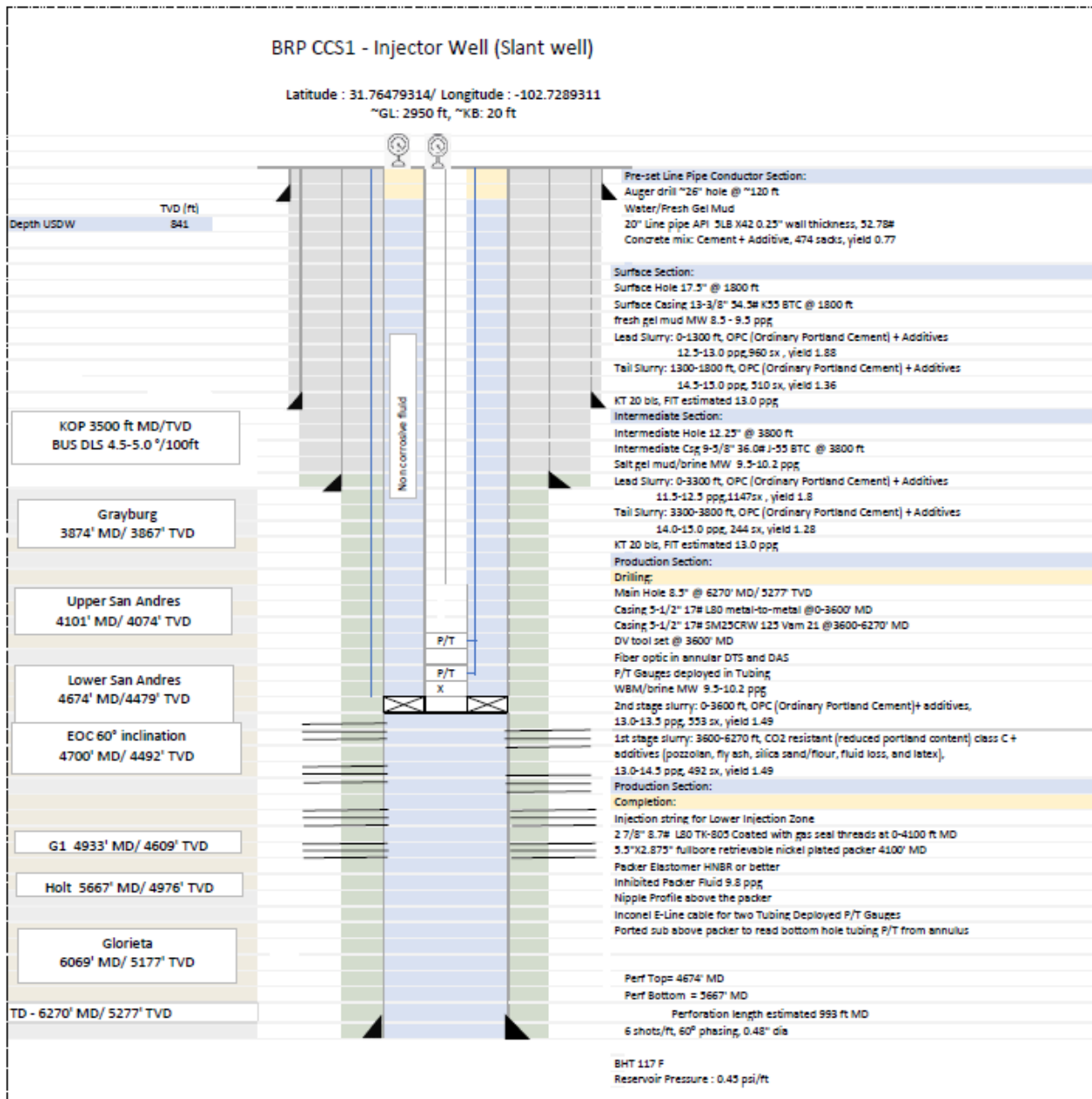

Figure 3—BRP CCS1 well proposed schematic

Details of BRP CCS1 well design are provided in the following tables. Table 3 contains the open hole diameters of each section, Table 4 lists the casing specifications, and Table 5 details the casing material properties. In addition, Table 7 contains the upper completion equipment specifications, and Table 8 shows the tubing material properties.

Table 3—Open Hole Diameters and Intervals for BRP CCS1

Name	Depth Interval (ft)	Open Hole Diameter (in.)	Comment
Conductor Section	0 to 120	26	Auger drill
Surface section	0 to 1,800	17 ½	Below base of USDW
Intermediate section	1,800 to 3800	12 ¼	Intermediate section
Long string section	3800 to 6270	8 ½	To total depth (TD)

Notes:

- The well TD includes a minimum 80 ft of cement shoe track, and 100 ft casing rat hole for completion operations in the Glorieta Formation.
- The USDW depth will be confirmed with open hole logs.

Table 4—Casing Specifications for BRP CCS1

Name	Depth Interval (ft)	OD (in.)	ID (in.)	Drift (in.)	Weight (lbm/ft)	Grade (API)	Coupling
Pre-set conductor	0 to 120'	20	19.5	19.25	52.78	5LB X42	weld
Surface string	0 to 1,800	13 3/8	12.615	12.459	54.5	K-55	BTC
Intermediate string	0 to 3,800	9 5/8	8.921	8.765	36	J-55	BTC
Long string	0 to 3,600	5 1/2	4.892	4.767	17	L80	LTC or Vam 21
Long string	3,600 to 6,270	5 1/2	4.892	4.767	17	SM25CRW-125*	Vam 21

*Casing material selection

Table 5—Casing Material Properties for BRP CCS1

Casing	Depth Interval (ft)	Burst (psi)	Collapse (psi)	Body Yield (Klb)
20 in conductor	0 to 120	-	-	-
13 3/8 -in. 54.5# K-55 BTC	0 to 1,800	2,730	1,130	853
9 5/8-in. 36# J-55 BTC	0 to 3,800	3,520	2,020	564
5 1/2 -in. 17# L80	0 to 3,600	7,740	6,290	397
5 1/2 -in. 17# SM25CRW-125	3,600 to 6,270	12,090	7,890	829

Notes:

- A stage tool will be located at ~3,000 to 4,000 ft in the 5-1/2-in. casing to perform the two-stage cement job.
- The centralization program will aim at 70- 90% standoff and will be adjusted using the field data for deviation, caliper, and hole conditions.
- DTS/DAS fiber optic cable will be deployed alongside the casing as part of the monitoring program. Special clamps, bands, and centralizers will be installed to protect the fiber and provide a marker for wireline operations.

Table 6—Direction design for BRP CCS1

Name	MD (ft)	Inclination (°)	Azimuth (°)	TVD (ft)	Dogleg (°/100ft)	Description
SHL	0	0	0	0	0.00	Surface hole location
KOP	3500	0	346	3500	0.00	Kick of point
EOC	4700	60	346	4492	5.00	End of curve
Well TD	6270	60	346	5277	0.00	Tangent section

Table 7—Upper Completion Equipment Specifications for BRP CCS1

Name	Depth Interval (ft)	OD (in.)	ID (in.)	Drift (in.)	Weight (lbm/ft)	Grade (API)	Coupling
Injection (Coated TK-805) tubing	0 to 4,100	2 7/8	2.441	2.347	6.5	L80	Special
Packer	Nickel-plated / HNBR (RGD) elastomers						

Table 8—Tubing Material Properties for BRP CCS1

Tubing	Depth Interval (ft)	Burst (psi)	Collapse (psi)	Body Yield (Ksi)
2 7/8-in. 6.5# L80 Special – Coated TK-805	0 to 4,100	10,570	11,170	80

Notes:

- Pressure and temperature gauges will be tubing-deployed above and below casing. Cable material will be Inconel®, and gauge carriers will be CO2-resistant material.

- The internal diameter of the tubing will be slightly reduced due to the TK-805 coating to be applied.
- The annular space between the 2 7/8-in. tubing and 5 1/2-in. casing will be filled with packer fluid.
- The packer depth will be adjusted once the final perforation depth interval is known.

4.2 BRP CCS2

The BRP CCS2 well design includes three main casing sections: 1) surface casing to cover the USDW and provide integrity while drilling to the Injection Zone, 2) intermediate section, and 3) a long string section to acquire formation data and isolate the target formation while running the upper completion equipment. Figure 4 presents wellbore trajectory of BRP CCS2 and Figure 5 is BRP CCS2 well proposed schematic.

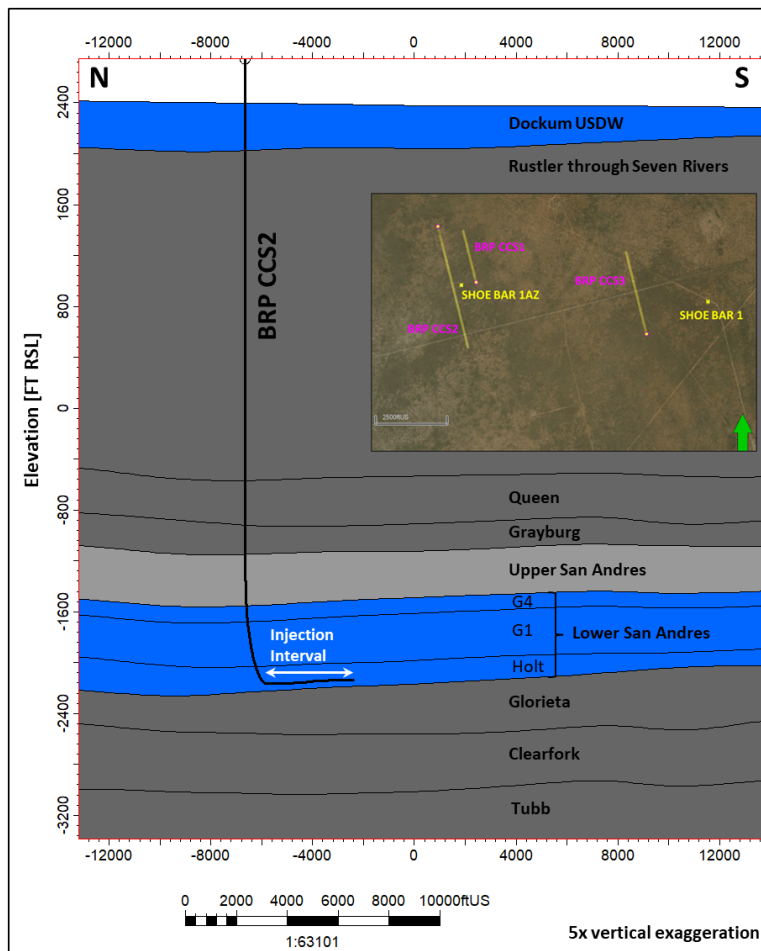

Figure 4—Wellbore trajectory of BRP CCS2 horizontal well with completion interval in sub-zone Holt highlighted in white.

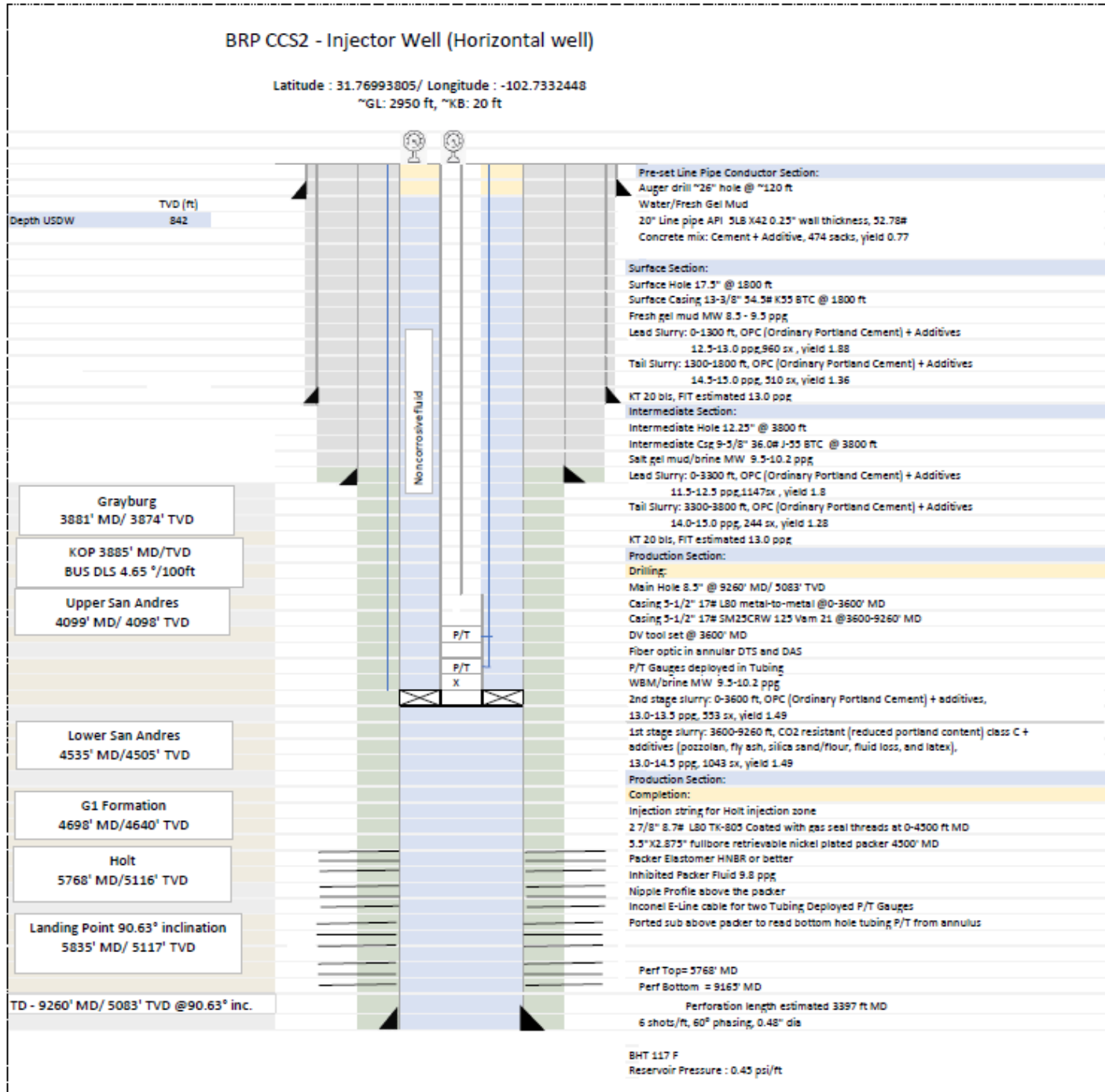

Figure 5—BRP CCS2 well proposed schematic

4.2.1 Design for BRP CCS2

Details regarding the BRP CCS2 well design are provided in the following tables. Table 9 contains the open hole diameters of each section, Table 10 lists the casing specifications, and Tables 11 details the casing material properties. In addition, Table 13 contains the upper completion equipment specifications, and Table 14 shows the tubing material properties.

Table 9—Open Hole Diameters and Intervals for BRP CCS2

Name	Depth Interval (ft)	Open Hole Diameter (in.)	Comment
Conductor Section	0 to 120	26	Auger drill
Surface section	0 to 1,800	17 ½	Below base of USDW
Intermediate section	1,800 to 3800	12 ¼	Intermediate section
Long string section	3800 to 9260	8 ½	To total depth (TD)

Notes:

- The well TD includes a minimum 80 ft of cement shoe track in the Holt Formation.
- The USDW depth will be confirmed with open hole logs.

Table 10—Casing Specifications for BRP CCS2

Name	Depth Interval (ft)	OD (in.)	ID (in.)	Drift (in.)	Weight (lbm/ft)	Grade (API)	Coupling
Pre-set conductor	0 to 120'	20	19.5	19.25	52.78	5LB X42	weld
Surface string	0 to 1,800	13 3/8	12.615	12.459	54.5	K-55	BTC
Intermediate string	0 to 3,800	9 5/8	8.921	8.765	36	J-55	BTC
Long string	0 to 3,600	5 1/2	4.892	4.767	17	L80	LTC or Vam 21
Long string	3,600 to 9,260	5 1/2	4.892	4.767	17	SM25CRW-125*	Vam 21

*Casing material selection

Table 11—Casing Material Properties for BRP CCS2

Casing	Depth Interval (ft)	Burst (psi)	Collapse (psi)	Body Yield (Klb)
20 in conductor	0 to 120	-	-	-
13 3/8 -in. 54.5# K-55 BTC	0 to 1,800	2,730	1,130	853
9 5/8-in. 36# J-55 BTC	0 to 3,800	3,520	2,020	564
5 1/2 -in. 17# L80	0 to 3,600	7,740	6,290	397
5 1/2 -in. 17# SM25CRW-125	3,600 to 9,260	12,090	7,890	829

Notes:

- A stage tool will be located at ~3,000 to 4,000 ft in the 5-1/2-in. casing to perform the two-stage cement job.
- The centralization program will aim at 70- 90% standoff and will be adjusted using the field data for deviation, caliper, and hole conditions.
- DTS/DAS fiber optic cable will be deployed alongside the casing as part of the monitoring program. Special clamps, bands, and centralizers will be installed to protect the fiber and provide a marker for wireline operations.

Table 12—Direction design for BRP CCS2

Name	MD (ft)	Inclination (°)	Azimuth (°)	TVD (ft)	Dogleg (°/100ft)	Description
SHL	0	0	0	0	0.00	Surface hole location
KOP	3885	0	346	3885	0.00	Kick of point
LP	5835	90.67	166	5117	4.64	Landing point
Well TD	9260	90.53	166	5083	0.00	Lateral section

Table 13—Upper Completion Equipment Specifications for BRP CCS2

Name	Depth Interval (ft)	OD (in.)	ID (in.)	Drift (in.)	Weight (lbm/ft)	Grade (API)	Coupling
Injection (Coated TK-805) tubing	0 to 4,500	2 7/8	2.441	2.347	6.5	L80	Special
Packer	Nickel-plated / HNBR (RGD) elastomers						

Table 14—Tubing Material Properties for BRP CCS2

Tubing	Depth Interval (ft)	Burst (psi)	Collapse (psi)	Body Yield (Ksi)
2 7/8-in. 6.5# L80 Special – Coated TK-805	0 to 4,500	10,570	11,170	80

Notes:

- Pressure and temperature gauges will be tubing-deployed above and below casing. Cable material will be Inconel®, and gauge carriers will be CO2-resistant material.
- The internal diameter of the tubing will be slightly reduced due to the TK-805 coating to be applied.
- The annular space between the 2 7/8-in. tubing and 5 1/2-in. casing will be filled with packer fluid.
- The packer depth will be adjusted once the final perforation depth interval is known.

4.3 BRP CCS3

4.3.1 Design for BRP CCS3

The BRP CCS3 well design includes three main casing sections: 1) surface casing to cover the USDW and provide integrity while drilling to the Injection Zone, 2) intermediate section, and 3) a long string section to acquire formation data and isolate the target formation while running the upper completion equipment. Figure 6 presents wellbore trajectory of BRP CCS3 and Figure 7 is BRP CCS3 well proposed schematic.

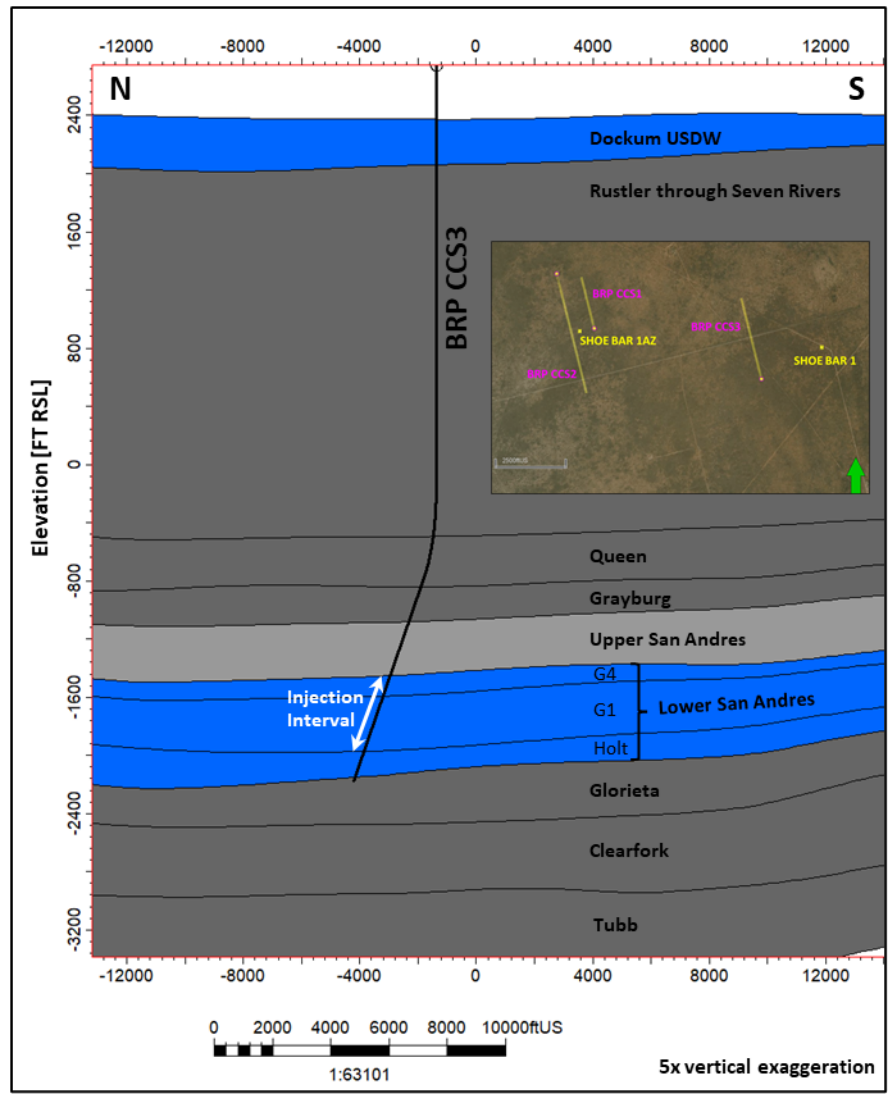

Figure 6—Wellbore trajectory of BRP CCS3 with completion interval in sub-zone G4-G1 highlighted in white

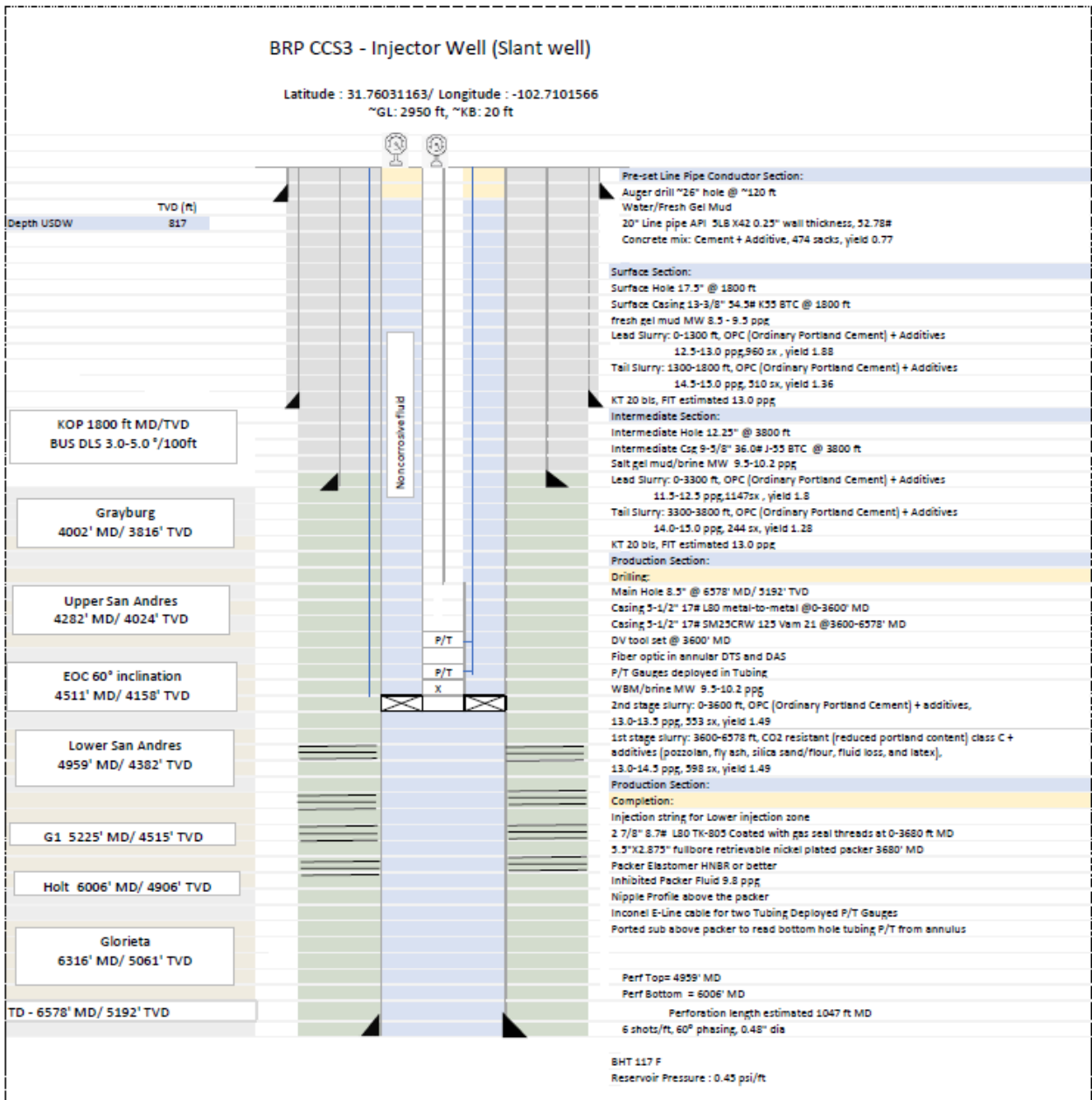

Figure 7—BRP CCS3 well proposed schematic

Details of BRP CCS3 well design are provided in the following tables. Table 15 contains the open hole diameters of each section, Table 16 lists the casing specifications, and Table 17 details the casing material properties. In addition, Table 19 contains the upper completion equipment specifications, and Table 20 shows the tubing material properties.

Table 15—Open Hole Diameters and Intervals BRP CCS3

Name	Depth Interval (ft)	Open Hole Diameter (in.)	Comment
Conductor Section	0 to 120	26	Auger drill
Surface section	0 to 1,800	17 ½	Below base of USDW
Intermediate section	1,800 to 3,800	12 ¼	Intermediate section
Long string section	3,800 to 6,578	8 ½	To total depth (TD)

Notes:

- The well TD includes a minimum 80 ft of cement shoe track, and 100 ft casing rat hole for completion operations in the Glorieta Formation.
- The USDW depth will be confirmed with open hole logs.

Table 16—Casing Specifications BRP CCS3

Name	Depth Interval (ft)	OD (in.)	ID (in.)	Drift (in.)	Weight (lbm/ft)	Grade (API)	Coupling
Pre-set conductor	0 to 120'	20	19.5	19.25	52.78	5LB X42	weld
Surface string	0 to 1,800	13 3/8	12.615	12.459	54.5	K-55	BTC
Intermediate string	0 to 3,800	9 5/8	8.921	8.765	36	J-55	BTC
Long string	0 to 3,600	5 1/2	4.892	4.767	17	L80	LTC or Vam 21
Long string	3,600 to 6578	5 1/2	4.892	4.767	17	SM25CRW-125*	Vam 21

*Casing material selection

Table 17—Casing Material Properties for BRP CCS3

Casing	Depth Interval (ft)	Burst (psi)	Collapse (psi)	Body Yield (Klb)
20 in conductor	0 to 120	-	-	-
13 3/8 -in. 54.5# K-55 BTC	0 to 1,800	2,730	1,130	853
9 5/8-in. 36# J-55 BTC	0 to 3,800	3,520	2,020	564
5 ½ -in. 17# L80	0 to 3,600	7,740	6,290	397

5 ½ -in. 17# SM25CRW-125	3,600 to 6578	12,090	7,890	829
--------------------------	---------------	--------	-------	-----

Notes:

- A stage tool will be located at ~3,000 to 4,000 ft in the 5-1/2-in. casing to perform the two-stage cement job.
- The centralization program will aim at 70- 90% standoff and will be adjusted using the field data for deviation, caliper, and hole conditions.
- DTS/DAS fiber optic cable will be deployed alongside the casing as part of the monitoring program. Special clamps, bands, and centralizers will be installed to protect the fiber and provide a marker for wireline operations.

Table 18—Direction design for BRP CCS3

Name	MD (ft)	Inclination (°)	Azimuth (°)	TVD (ft)	Dogleg (°/100ft)	Description
SHL	0	0	0	0	0.00	Surface hole location
KOP	1800	0	346	1800	0.00	Kick of point
EOC	4511	60	346	4158	5.00	End of curve
Well TD	6578	60	346	5192	0.00	Tangent section

Table 19—Upper Completion Equipment Specifications

Name	Depth Interval (ft)	OD (in.)	ID (in.)	Drift (in.)	Weight (lbm/ft)	Grade (API)	Coupling
Injection (Coated TK-805) tubing	0 to 3680	2 7/8	2.441	2.347	6.5	L80	Special
Packer	Nickel-plated / HNBR (RGD) elastomers						

Table 20—Tubing Material Properties

Tubing	Depth Interval (ft)	Burst (psi)	Collapse (psi)	Body Yield (Ksi)
2 7/8-in. 6.5# L80 Special – Coated TK-805	0 to 3680	10,570	11,170	80

Notes:

- Pressure and temperature gauges will be tubing-deployed above and below casing. Cable material will be Inconel®, and gauge carriers will be CO2-resistant material.
- The internal diameter of the tubing will be slightly reduced due to the TK-805 coating to be applied.
- The annular space between the 2 7/8-in. tubing and 5 1/2-in. casing will be filled with packer fluid.

- The packer depth will be adjusted once the final perforation depth interval is known.

5.1 Pressure Testing

- BOPE components (including the BOP stack, choke manifold, and choke lines) shall be pressure tested at the following frequency:
 - When installed. If the BOPE is stump tested, only the new connections are required to be tested at installation.
 - Before 21 days have elapsed since the last BOPE pressure test. When the 21-day test is due soon, consider testing the BOPE prior to drilling H₂S, abnormal pressure, or any lost return zones to avoid having to test while drilling these intervals.
 - Anytime a BOPE connection seal is broken, the connection shall be pressure tested after reassembly and before use.
 - When utilizing tapered strings, variable bore-type rams and annular preventers shall be pressure tested with all tubing or drill pipe sizes anticipated to be used.
- BOPE shall be tested using a test plug or other means to isolate the casing and open hole from the test pressures. The casinghead valve shall be opened and monitored to avoid exerting BOPE test pressure on the casing or open hole.
- BOPE components shall first be low-pressure tested to between 250 and 350 psi. If the pressure exceeds 350 psi during this test, the pressure shall be bled off to 0 psi and the test restarted. Pressuring up beyond 350 psi can induce a seal and give a false test result.
- BOPE components, excluding the annular preventer, shall be tested to the lesser of rated working pressure (RWP) or wellhead RWP if less than BOPE RWP. The annular preventer shall be tested to 70% of its RWP. In all cases, the test pressure shall not exceed the RWP of any of the components being tested.
- Use of a cup tester should be avoided. If a cup tester is utilized for BOP testing, consideration shall be given to casing burst pressure and possible pressure applied to the casing string or open hole below the cup tester in the event of a leaking cup tester.
- An accumulator closing test shall be performed after the initial nipple-up of the BOP, after any repairs that required isolation or partial isolation of the system, or at initial nipple-up on each well.
- During drilling, the pipe rams shall be functionally operated at least once every 24 hours. The blind rams shall be functionally operated each trip out of the wellbore.

5.2 Wellhead Schematic

Figure 8 below is a schematic diagram of the wellhead to be used for the BRP CCS1, BRP CCS2 and BRP CCS3 wells.

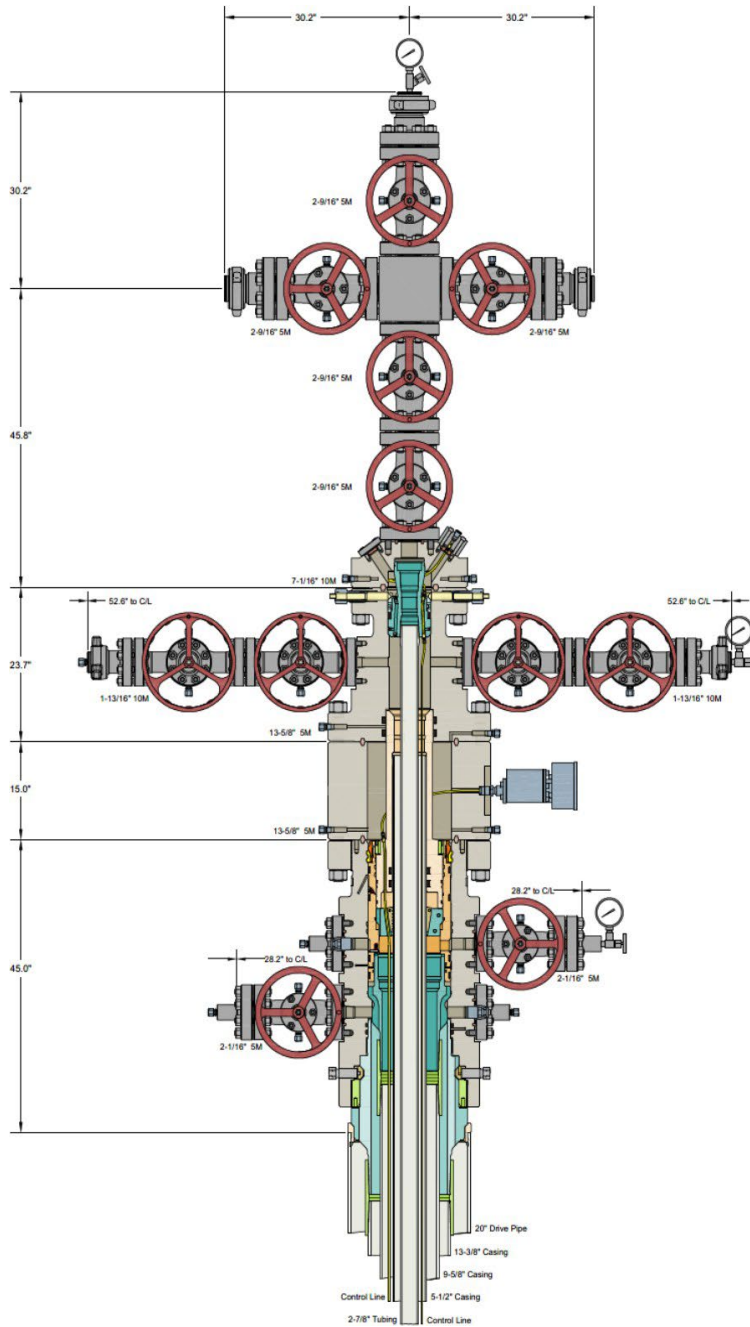

Figure 8—Schematic diagram of BRP CCS1 and BRP CCS2 wellhead

ATTACHMENT 5: STIMULATION PLAN

Facility name: Brown Pelican CO2 Sequestration Project
BRP CCS1, CCS2, and CCS3 wells

Well location: Penwell, TX

BRP CCS1	31.76479314	-102.7289311
BRP CCS2	31.76993805	-102.7332448
BRP CCS3	31.76031163	-102.7101566

1.0 Introduction and Purpose

Oxy Low Carbon Ventures (OLCV) may stimulate the injection zone for the Brown Pelican (BRP) Project to enhance the injectivity potential of CO₂ injection wells and the productivity of water withdrawal wells. Stimulation may involve, but is not limited to, flowing fluids into or out of the well, increasing or connecting pore spaces in the injection/production formation, or other activities that are intended to allow CO₂ to move more readily into the injection zone and for the water to be more efficiently produced.

OLCV will adhere to all applicable regulatory requirements for any stimulation treatment that may be required. Specifically, and without limitation, OLCV will comply with the following:

- 40 CFR 146.82(a)(9): OLCV will submit the proposed stimulation program, a description of stimulation fluids to be used and a determination that stimulation will not interfere with containment.
- 40 CFR 146.88(a): Except during stimulation, OLCV will ensure that injection pressure does not exceed 90 percent of the fracture pressure of the injection zone(s) so as to ensure that the injection does not initiate new fractures or propagate existing fractures in the injection zones(s). In no case will injection pressure initiate fractures in the confining zones(s) or cause movement of injection or formation fluids that endanger a USDW.
- 40 CFR 146.91(d)(2) and (e): OLCV will notify the Director in writing 30 days in advance of any planned stimulation activities, other than stimulation for formation testing conducted under 40 CFR 146.82. Regardless of whether a state has primary enforcement responsibility, OLCV shall submit all required reports, submittals, and notifications under subpart h of this part to EPA in an electronic format approved by EPA.

The information provided in this section specifically addresses the stimulation fluids, additives, and proposed stimulation procedures OLCV may implement. This plan includes multiple stimulation methodologies that may be selected based on site-specific technical and operational conditions that may impact future well performance. The methods provided below may also be used to remediate scaling or perforation occlusion in the well.

1.1 Purpose of Stimulation

Perforated intervals in the Lower San Andres CO₂ injection / water production zone may require stimulation periodically throughout the project life to enhance performance with the aim to restore it to initial or optimum conditions. For example, stimulation may be needed to remediate injectivity loss resulting from mineral scales, clay fragments, metallic sulfide, or oxide particulates. Stimulation may also be necessary to remove any near-wellbore damage resulting from drilling and completion operations. Following well construction, remedial stimulation may be conducted before the commencement of CO₂ injection or water withdrawal.

2.0 Stimulation Fluids

At BRP, OLCV will use acid blends for matrix stimulation that are typical for the industry. These include, but are not limited to, mixtures of acetic, hydrochloric, hydrofluoric, and/or other organic acids. These blends have been historically proven to remove near-wellbore damage caused by mineral scales, drilling muds, completion fluids, and clay fines while minimizing negative impacts to permeability. There is also a potential for near-wellbore halite precipitation in the CO₂ injectors, which may require remediation by periodic flushes with less saline water.

All chemical treatments will be evaluated and selected for compatibility with the treatment method. For example, mineral acids will be treated with chemical inhibitors to prevent corrosion damage to the tubing string. In addition, chemical systems will be evaluated and selected to avoid damage to the down hole packer sealing elements, casing, and other seals within the injection system that might be exposed to the chemicals.

2.1 Additives

Additives may be utilized with the stimulation fluids to aid matrix stimulation while mitigating corrosion of tubulars and potential damage to the sequestration zone. These additives include, but are not limited to, corrosion or acid inhibitors, scale inhibitors, clay stabilizers, biocides, demulsifiers, chelating agents, mutual solvents, iron sequestrants, retarders, and/or

surfactants. Compatibility of these additives with the stimulation fluids, tubulars and the reservoir will be confirmed prior to their use in any stimulation activities.

2.2 Diverters

Nitrogen or CO₂ may be added to stimulation fluids to achieve improved diversion and effective treatment for the target zone by diverting the stimulation fluids to the most impaired (*i.e.*, low injectivity/productivity) perforations. Depending on the well-specific requirements and stimulation design, organic or polymeric diverting agents may also be selected. These diverters provide temporary restrictions during stimulation operations and degrade or break-down with time due to water solubility and temperature.

The most suitable diverting agent will be selected based on one or more factors, including, anticipated pump rates, the length of the perforated interval, perforation density, and the selected technique for conveying acid to the injection zone (*e.g.*, pumping through regular tubing or pumping down coiled tubing).

3.0 Mechanical Stimulation

In addition to chemical stimulation, mechanical stimulation of the well may be required independently, or in conjunction with chemical stimulation. Mechanical stimulation may be required if there is deposition that cannot be easily remediated with chemicals, or if mechanical means may be more effective. These mechanical options include, but are not limited to, backflow, adding perforations, or re-perforating. Perforating operations may be further enhanced with the use of propellants. Propellant stimulations will be designed for nominal height growth, and to remain within the injection zone and avoid fracture growth into the confining layer (Wieland, 2006).

4.0 Ensuring Containment

Except during stimulation, injection pressure will not exceed 90% of the established fracture pressure for the injection zone. Injection pressure at the downhole tubing pressure gauge and tubing/annulus surface gauges will be continuously monitored during the stimulation operation.

Stimulation of the injection interval will be conducted to avoid affecting the confining layers. Perforations in the injection zone will be vertically separated from the base of the confining layers by a minimum of 10 feet. Chemicals injected into perforations in the injection zone will not come into contact with the confining layers.

5.0 Standard Stimulation Procedure

If injection rates decline below expected values at any time during the project life, OLCV may investigate the cause to determine whether stimulation may be required. Investigation activities may include, without limitation, the following:

- Logging operations, including but not limited to, evaluation of the injection/production profile, mechanical spinner surveys, caliper logging, downhole camera investigation, etc.
- Collecting downhole samples when necessary or feasible with wireline, slickline or coiled tubing conveyed sampling equipment, to be followed by analytical testing as appropriate to determine remediation options.

A standard stimulation procedure is outlined below. This procedure may be modified depending on site-specific operational and technical conditions and the specific treatment requirements. The conveyance methods may include coil tubing, tubing-conveyed retrievable straddle packer assembly, snubbing unit, tubing flush, or bullheading.

1. Test the potential stimulation fluids blends for compatibility with well materials, reservoir rock, and fluids.
2. Design the stimulation program.
3. Provide the recommended work procedure and stimulation program to the UIC Program Director in writing at least 30-days prior to the planned date for start of the work (40 CFR 146.91(d)(2)).
4. Perform pre-job planning.
5. Discuss job safety and monitoring assignments.
6. Prepare the location for rig up of stimulation equipment.
7. Shut-in the injection or water withdrawal well, allowing the pressures to stabilize at the well and for other wells and the facility to absorb rate and pressure changes.
8. Rig up the stimulation well intervention equipment.
9. Prepare the well for stimulation.
10. Perform the matrix stimulation as specified in this plan.
11. Flush the wellbore with treated water and prepare the well to return to normal operation.
12. Rig down and return the well back to injection or water production.

A similar procedure would be utilized for flowbacks with prior operation-specific planning for well control as well as other job-specific safety and environmental protection control practices.

ATTACHMENT 6: TESTING AND MONITORING PLAN

Facility Information

Facility name: Brown Pelican CO2 Sequestration Project
BRP CCS1

Well location: Penwell, TX
31.76479314, 102.7289311

1.0 Overall Strategy and Approach for Testing and Monitoring

The Testing and Monitoring Plan was designed to monitor and mitigate the key risks identified for this project that are described in the Emergency and Remedial Response Plan (part of this application). During the Injection and Post-injection periods, those risks include the potential for: well integrity failure, leakage to USDW, natural disasters, induced seismicity or critical surface impacts. The testing and monitoring methods included in this document are mitigations and controls to prevent CO2 or brine leakage out of the Injection Zone that could endanger the USDWs, migrate to a different stratum, or create a risk for people or the environment.

In addition, the testing and monitoring program is tailored to track the migration of the CO2 plume and development of the pressure front within the Injection Zone. Data will be collected prior to injection to establish a baseline. Data collected during the injection and post-injection periods from the testing and monitoring program will help to validate the simulation models and re-evaluate the AoR.

The testing and monitoring program includes controls and mitigations in the following categories:

1. Carbon dioxide stream analysis
2. Continuous recording of operational parameters: injection rate, volume, pressure, temperature, and internal mechanical integrity
3. Corrosion monitoring and leak detection
4. Above confining zone monitoring, including the first permeable zone above the confining zone, which is coincident with the lowermost USDW, and the near-surface
5. Internal and external mechanical integrity testing
6. Pressure fall-off testing
7. Carbon dioxide plume and pressure front tracking

8. Surface Monitoring

The methodology and frequency of testing and monitoring methods is expected to change throughout the life of the project. Pre-injection monitoring and testing will focus on establishing baselines and ensuring that the site is ready to receive injected CO₂. Injection phase monitoring will be focused on collecting data that will be used to calibrate models and ensure containment of CO₂. Post-injection phase monitoring and testing is designed to demonstrate CO₂ plume stabilization and ensure containment. The testing and monitoring plan will be reviewed at least once every five years and will be amended, if necessary, to ensure monitoring and storage performance is achieved and new technologies are appropriately incorporated.

Data obtained from the testing and monitoring plan will be used to inform operational decisions on the quantity and rate of CO₂ injected and potential containment actions. Data will be used to improve computational model forecasts. Data that is interpreted to be inconsistent with model predictions will trigger additional testing, monitoring and evaluation.

A summary of the proposed testing and monitoring methods and timing of testing and monitoring is listed in Table 1.

Table 1—Summary of Testing and Monitoring Frequency

Objective	Method	Frequency Pre-Injection	Frequency During Injection	Frequency Post-Injection
CO ₂ injectate stream analysis	On-line gas chromatograph and/or gas analyzers in flowline and sampling in flowline	Chemical and isotopic characterization prior to injection	Continuous monitoring using gas chromatograph and/or analyzers; quarterly or event-driven ¹ sampling for composition; and isotopic analysis if capture process materially changes source stream	N/A
Continuous recording of operational parameters in injection wells: injection rate, volume, pressure, and temperature	Surface and tubing-conveyed pressure and temperature gauges, DTS fiber, and injection line flowmeter	Measurement prior to injection	Continuous measurement and recording	N/A
Corrosion Monitoring in injection wells and surface leak detection	Coupons, visual inspection at wellhead, LDAR/OGI cameras, surface sensors, and DTS	Inspection prior to injection	Quarterly coupon testing, weekly visual inspection, quarterly inspection via LDAR/OGI cameras, and continuous monitoring via surface sensors and DTS	Continuous surface monitoring and quarterly visual inspection until site closure
Internal mechanical integrity	Pressure and temperature gauges, DTS, Annulus pressure monitoring, tubing-casing monitoring	Measurement prior to injection	Continuous measurement and recording	N/A
External mechanical integrity testing	Pressure and temperature gauges, DTS, and MIT	Measurement prior to injection	Continuous measurement and recording; and routine MIT	N/A

Near well-bore formation properties testing (Pressure fall-off testing)	Pressure fall-off test	Measurement prior to injection	Once during every five-year period until plugging	N/A
In-zone pressure, temperature, CO2 saturation and geochemistry	Pressure and temperature gauges and/or DTS; saturation logging, and fluid and dissolved gas sampling	Characterization prior to injection, including quarterly fluid and dissolved gas sampling; cased hole saturation logging; PT gauge and DTS measurements prior to injection	Continuous measurement and recording of pressure and temperature; annual saturation profile; event-driven* fluid sampling, triggered by changes in P/T	P/T: Continuously for the first 10 years pending an approved PISC plan, then annually until plugging; saturation profile annually; event-driven* fluid and dissolved gas sampling, triggered by P/T data
Geochemistry of the first permeable zone above the confining zone and the lowermost USDW (Dockum Group)	Fluid and dissolved gas sampling and analysis in USDW1 well	Characterization prior to injection, including quarterly fluid and dissolved gas sampling for at least one year	Quarterly geochemical sampling in years 1-3 and annually starting in year 4; and, event-driven*, triggered by P/T data in SLR2 or SLR3 wells	Annually for first 10 years post injection pending an approved PISC plan; event-driven*, triggered by P/T data in SLR2 or SLR3 wells thereafter
Soil gas analysis (vadose zone; near surface)	Isotopic analysis and chemical evaluation at approximately 21 locations	Characterization prior to injection, including quarterly sampling for at least one year prior to commencement of injection	Quarterly gas composition sampling in years 1-3 and annually starting in year 4 for subset of stations, and event-driven*, triggered by P/T data in SLR2, SLR3 or USDW1 monitor wells and fluid sample results	Event-driven*, triggered by P/T data in SLR2, SLR3 or USDW1 monitor wells and fluids sample results
Containment of CO2 in Injection Zone	Pressure and temperature gauges and/or DTS; saturation logging, and event-driven* fluid and dissolved gas sampling	Characterization prior to injection, including quarterly sampling for approximately one year in WW	Continuous measurement and recording of pressure and temperature (SLR1 and WWs); event-triggered fluid sampling in WWs;	P/T or DTS: continuously for the first 10 years in SLR1 well or until plugging, pending an approved PISC plan;

		wells; saturation logging in the Upper Confining Zone in SLR1 and ACZ1	saturation logging once every five year period in SLR1 and ACZ1 wells	Saturation logging: event-driven* in the SLR1 or ACZ1
Non-endangerment of shallow groundwater and soil	Geochemical and isotopic monitoring to detect deviations from expected groundwater and soil gas chemistry	Characterization prior to injection: quarterly	Groundwater and soil gas sampling: Quarterly analysis in years 1-3, then annually after that; and, event-driven*, triggered by P/T data in SLR wells	Event-driven*
CO2 plume and pressure movement within the Injection Zone	Pressure and temperature gauges and/or DTS; and event-driven* fluid sampling	P/T measurement, fluid sampling prior to injection in the SLR2 and WW wells	Continuous P/T measurement in SLR2 and SLR3 wells; event-driven* fluid sampling in SLR or WW wells	P/T recording bimonthly for the first five years post-injection, then annually until well is plugged or plume stabilizes in SLR2 or SLR3 wells
Indirect geophysical monitoring of plume and pressure	2D VSP utilizing in-well fiber or wireline conveyed geophones; surface 2D; saturation logging; DInSAR and GPS	Prior to injection	Annual saturation logging in SLR2 and SLR3 wells; 2D VSP after 1, 2, 5 and 10 years; 2D surface seismic at year 10 and approximately every five years thereafter; Quarterly DInSAR and GPS	Annual saturation logging in SLR2 and SLR3 wells; surface 2D VSP once every approximately five-year period until plugging; 2D surface seismic once every approximately five years until plume stabilization Annual DInSAR and GPS for first five years post-injection
Presence or absence of seismicity	Seismometers	Prior to injection	Continuous monitoring and recording	Continuous monitoring and recording until site closure

¹Event-driven sampling of CO2 injectate stream will be triggered if there are changes in the DAC process that may arise from facility upgrades or after facility shut-in periods.

*OLCV will monitor pressure and temperature data obtained from downhole gauges and/or DTS fiber daily, and also routinely evaluate long-term data trends to detect deviations from

the reference temperature or pressure gradient. If persistent deviations in temperature or pressure are detected, OLCV will obtain reservoir fluid samples and analyze fluid and dissolved gas chemistry to determine the presence or absence of increased CO₂. In addition, fluid and dissolved gas chemistry data from the lowermost USDW and soil gas chemistry from shallow soils will be monitored for trends to detect deviations from reference chemistry. If persistent and/or abrupt anomalies in chemistry are detected additional fluid or soil gas samples will be obtained to confirm the presence or absence of increased CO₂.

1.1 Well Monitoring Network Design

Multiple testing and monitoring objectives described in Table 1 will be accomplished by evaluating data from monitoring wells (Table 2). These wells will provide direct measurements to compliment indirect measurement methods for monitoring the AoR. In addition, data from monitoring wells will be used to characterize fluid chemistry and isotopic composition throughout the stratigraphic column. A summary of data by well type is shown in Table 3.

OLVC plans to install a Single Reservoir-level (SLR) well, the SLR2, in the Injection Zone prior to the commencement of CO₂ injection, and OLCV has already installed a well to monitor the Underground Source of Drinking Water Aquifer (USDW) in the lowermost USDW, the Dockum Group. The SLR3 well is anticipated to be drilled within five years after the commencement of injection and its location will be refined after commencement of operations. The need for additional monitoring wells will be evaluated as needed, and at least annually during the injection period and until plume stabilization. OLCV describes below the locations of monitoring wells to be installed prior to first injection and the proposed locations of future monitoring wells.

In addition to SLR2 and SLR3 wells, the Injection Zone will be directly monitored with data collected in four Water Withdrawal wells (WW). The WW wells will extract brine to manage pressure in the Injection Zone. The brine will be transported via pipeline for use in Oxy or third- party operations or transported to the location of planned Class I disposal wells. The CO₂ injectate plume is not expected to reach the WW1, WW3 and WW4. If the CO₂ plume does reach these WW wells, they will be shut in. The CO₂ injectate plume is expected to reach WW2. When the plume in the Holt sub-zone reaches WW2, the well will be plugged above the Holt and continue to produce brine from the upper portion of the Lower San Andres. The CO₂ injectate plume from the upper part of the Lower San Andres (Lower San Andres sub-zone and G1 sub-zone) is not expected to reach the WW2.

Note that OLCV previously intended to utilize the Shoe Bar 1 and Shoe Bar 1 AZ to monitor

the first permeable zone above the confining zone. Wireline testing in the water withdrawal wells conducted in Spring 2024 indicates the absence of permeable zones above the confining zone and below the lowermost USDW. Therefore, the Dockum group is the both the lowermost USDW and the first permeable zone above the confining zone. The Shoe Bar 1USDW well will be used to monitor geochemistry in the Dockum group to meet 40 CFR 146.90(d).

Table 2—Planned wells used for monitoring

Regulatory Well Name	Project Well Name	Drill Date	Purpose	~TD (ft)	Latitude (NAD 27)	Longitude (NAD 27)
Shoe Bar 1	SLR1	2023	Upper Confining Zone Monitor	6585, ~4200 ¹	31.76343602	-102.7034981
Shoe Bar 1AZ	ACZ1	2023	Upper Confining Zone Monitor	6725, ~4300 ¹	31.74670102	-102.7259011
Shoe Bar 2SLR	SLR2	2025	Injection Zone monitor	5271	31.76448869	-102.7305326
Shoe Bar 3SLR	SLR3	~2030, five years after the commencement of injection	Injection Zone monitor	5316	31.76411900	-102.7316750
Shoe Bar 1USDW	USDW1	2023	Lowermost USDW monitor	850	31.78023685	-102.7418093
Shoe Bar 1WW	WW1	2024	Water withdrawal, Injection Zone monitor	5053	31.76289539	-102.6959232
Shoe Bar 2WW	WW2	2024	Water withdrawal, Injection Zone (G1-G4) monitor	5314, 4947 ²	31.78419981	-102.7275869

Shoe Bar 3WW	WW3	2024	Water withdrawal, Injection Zone monitor	5106	31.75008553	-102.7102206
Shoe Bar 4WW	WW4	2024	Water withdrawal, Injection Zone monitor	5337	31.76384464	-102.7539505

¹Anticipated TD following conversion to monitor well

²Anticipated TD following plugging above Holt zone

Table 3—Summary of monitoring by well type and project stage

Well type	Objective	Method	Monitoring Pre-Injection	Monitoring During Injection	Monitoring Post-Injection
SLR2 and SLR3; Injection Zone monitoring	Direct monitoring of CO ₂ plume and pressure front	Downhole and surface pressure and temperature gauges or DTS (selected wells)	Baseline sampling in SLR2	Continuous	Continuously for the first 10 years pending an approved PISC plan, then annually until plugging
	Direct measurement of fluids to detect CO ₂	Fluid and dissolved gas sampling via wireline or U-tube	Baseline sampling in SLR2	Event-driven*	Event-driven*, until plugging
	Indirect monitoring of CO ₂ concentration	Pulsed Neutron Log (PNL) or Reservoir Saturation Tool (RST) log	Baseline sampling in SLR2	Annually	Annually until plugging
	Indirect geophysical monitoring of plume and pressure	2D VSP (selected wells)	Baseline survey in SLR2	At years 1, 2, 5 and 10 in SLR2	Once every approximately five-year period until plugging in SLR2

	Internal and external mechanical integrity	Pressure and temperature (P/T) gauges or DTS; and external MIT	Baseline data in SLR2	Continuous P/T MIT log once every five-year period	MIT log once every five-year period and before plugging
	Corrosion monitoring	Casing inspection logging	NA	Once every five-year period	Once every five-year period until plugging
	Surface leak detection	Visual inspection at wellhead, LDAR/OGI cameras, surface sensors	NA	Weekly to quarterly, depending on tool	Continuous surface monitoring and quarterly visual inspection until site closure
SLR1 and ACZ1; Upper Confining Zone monitoring	Direct monitoring of pressure and temperature to ensure Upper Confining Zone integrity	Downhole and surface pressure and temperature gauges and/or DTS (SLR1)	Prior to injection	Continuously	Continuously for the first 10 years pending an approved PISC plan
	Indirect monitoring of CO2 presence above the Injection Zone	PNL or RST log	Prior to injection	Once every five year-period	Event-driven* until plugging
	Internal and external mechanical integrity	Pressure and temperature gauges; external MIT	Prior to injection	MIT log once every five-year period	MIT log once every five-year period and before plugging
	Surface leak detection	Visual inspection at wellhead, LDAR/OGI cameras, surface sensors	NA	Weekly to quarterly, depending on tool	Continuous surface monitoring and quarterly visual inspection until site closure

USDW1; Lowermost USDW monitoring	Geochemical and isotopic monitoring to detect deviations from expected fluid chemistry	Fluid and dissolved gas sampling using a bladder pump	Baseline sampling	Quarterly sampling in years 1-3, annually starting in year 4; and event-driven*	Annually for the first 10 years post injection pending an approved PISC plan; and event- driven*, until plugging
WW1, WW2, WW3, WW4; Injection Zone monitoring	Geochemical and isotopic monitoring to detect to detect CO2	Fluid sampling at the wellhead	Baseline sampling	Event-driven*	Event- driven*, until plugging

*OLCV will monitor pressure and temperature data obtained from downhole gauges and/or DTS fiber daily, and also routinely evaluate long-term data trends to detect deviations from the reference temperature or pressure gradient. If persistent deviations in temperature or pressure are detected, OLCV will obtain reservoir fluid samples and analyze fluid and dissolved gas chemistry to determine the presence or absence of increased CO₂. In addition, fluid and dissolved gas chemistry data from the lowermost USDW and soil gas chemistry from shallow soils will be monitored for trends to detect deviations from reference chemistry. If persistent and/or abrupt anomalies in chemistry are detected additional fluid or soil gas samples will be obtained to confirm the presence or absence of increased CO₂.

2.0 Carbon Dioxide Stream Analysis

OLCV will analyze the CO₂ stream during the operation period to yield data representative of its chemical and physical characteristics and to meet the requirements of 40 CFR §146.90(a).

The source of the CO₂ for the Project is a Direct Air Capture (DAC) facility that is located near the proposed CO₂ sequestration site. The DAC facility will extract CO₂ from air, and the composition of the produced stream will be primarily composed of CO₂, O₂ and H₂O. The DAC extraction process prevents other components from being incorporated into the resulting stream.

2.1 Location and Frequency

The CO₂ injectate stream (Table 4) will be continuously monitored at the DAC facility before

the injectate enters the flowline to BRP. In addition, the CO₂ injectate stream will be continuously monitored using an online gas chromatograph or gas analyzers directly upstream of the CO₂ Injector's wellheads. CO₂ stream samples will be routinely collected at a sample port in the flowline near the Injector wellheads. Continuous online monitoring of the CO₂ injectate composition, coupled with routine laboratory analysis will provide appropriate data resolution and, in the unlikely event that impurities are present, detect those impurities that might alter the corrosivity or other properties of the injectate downhole. See Table 5 for a summary of injectate monitoring plans.

The isotopic composition of the CO₂ stream will be analyzed prior to injection. This will allow for fingerprinting of the injectate stream and comparison with fluid samples obtained from SLR, WW or USDW wells during the Injection or Post-Injection periods.

If online gas chromatography / gas analyzer or laboratory analysis indicate that the CO₂ injectate stream exceeds the specifications described in Table 4, the system is alarmed to alert OLCV personnel. Based on operational experience, minor system upsets are resolved in a few minutes and the composition is restored to the specification. If the composition is not restored to the specification, or the source of the issue cannot be quickly resolved, CO₂ capturing operations at the DAC facility will be shut-in until the injectate stream meets the specification. If the DAC process is stopped, CO₂ stream will not move to the final compression system or enter the pipeline for transport to the sequestration site. This process ensures that the CO₂ stream composition entering the CO₂ Injectors is consistent with the expected composition.

Table 4—CO2 Injectate Stream Specification

Component	Specification
CO2 content	>95 mol% (>96.5 mass%)
Water	<30 lbm/MMscf
Nitrogen	<4 mol%
Sulphur	<35 ppm by weight
Oxygen	<5 mol%
Glycol	<0.3 gal/MMscf
Carbon Monoxide	<4,250 ppm by weight
NOx	<6 ppm by weight
SOx	<1 ppm by weight
Particulates (CaCO3)	<1 ppm by weight
Argon	<1 mol%
Surface pressure	>1,600 psig
Surface temperature	>65°F and <120°F
Isotopes	$\delta^{13}\text{C}$ and ^{14}C of CO2

Table 5—CO2 injectate stream monitoring method and frequency

Method	Pre-Injection	Injection	Post-Injection
Online gas chromatography / gas analyzer of supercritical CO2 in the flowline upstream of the injector wells	NA	Continuously	N/A
Laboratory gas chromatography of samples obtained from a sample port upstream of the injector wells	N/A	Quarterly; or event-driven* if the DAC process materially changes	N/A
Laboratory isotopic analysis of injectate samples	Prior to injection	Event-driven* if the DAC process materially changes	NA

*Event-driven = changes in the DAC process that may arise from facility upgrades or after facility shut-in periods.

2.1.1 Stream Monitoring at DAC facility

The DAC facility will be equipped with an online analyzer including an O₂ optical sensor and a H₂O aluminum oxide sensor to continuously monitor for O₂ and H₂O and ensure the injectate stream meets specification. In addition, gas-phase samples at known temperature and pressure will routinely be collected from the DAC facility for laboratory analysis. The DAC facility will be equipped with an on-site laboratory to measure the composition and conduct isotopic analysis of the CO₂ stream. The DAC facility is designed to prevent CO₂ injectate from entering the pipeline to sequestration if the composition does not meet the specification.

3.1.2. Stream Monitoring in the Flowline

In addition to the continuous monitoring and on-site laboratory analysis at the DAC facility, the CO₂ stream will be continuously recorded and routinely sampled directly upstream of the flowmeter near the CO₂ injector wellhead (40 CFR §98.440-98.449). A gas chromatograph and/or gas analyzers will be installed along the flowline near the flowmeter and the data will be continuously monitored at a control room staffed with personnel employed by Oxy, OLCV or its subsidiaries or third-party contractors. A sample port will be installed directly upstream of the flowmeter to allow extraction of the CO₂ stream in a supercritical phase. The samples will be collected, transported to a laboratory, and analyzed by a qualified third-party contractor experienced with analyzing gases.

3.1.3. CO₂ Isotopic Analysis

In addition to the gas composition analysis, CO₂ stream samples from the flowline port will be collected for isotopic characterization. These data will be used to determine a baseline and complement the gas, soil, and water characterization methods. Samples for isotopic compositional baseline analysis will be sent to a commercial laboratory for evaluation.

2.2 Analytical Parameters

The 1PointFive DAC facility has developed a standard CO₂ specification, as shown in Table 4. OLCV will notify the EPA before any anticipated change in CO₂ composition. In addition, any changes to the physical, chemical, and other relevant characteristics of the CO₂ stream from the established operating data specified in the permit, or a demonstration that these characteristics have not changed since the previous reporting period, shall be described in a semi-annual report, and submitted to the EPA in compliance with 40 CFR §149.91(a).

2.3 Sampling Methods

Sample collection for laboratory analysis will follow the procedure outlined in GPA-2177-20

to ensure that the sample is representative of the injected CO₂ stream. A sampling station will be installed with the ability to purge and collect samples into a container that will be sealed and sent to the third-party authorized laboratory. A third-party contractor will be responsible for collecting the samples, transporting the samples to a laboratory, and for sample analysis.

2.4 Laboratory to be Used, Chain of Custody, and Analysis Procedures

The samples will be analyzed in accordance with GPA-2177-20 by a third-party laboratory. Sampling procedures will follow contractor protocols to ensure the sample is representative of the injectant and samples will be processed, packaged, and shipped to the contracted laboratory, following standard sample handling and chain-of-custody guidance.

3.0 Continuous Recording of Operational Parameters

OLCV will install and use continuous recording devices to monitor injection pressure, rate, volume; the pressure on the annulus between the tubing and the long string casing; and the temperature of the CO₂ stream, as required by 40 CFR §146.88(e)(1), §146.89(b), and §146.90(b).

3.1 Monitoring Location and Frequency

Injection operations will be continuously monitored and controlled by the operations staff utilizing a process control system. The system will continuously monitor, control, record, and alarm for critical system parameters of pressure, temperature, and injection flow rate. The system will initiate a shutdown if specified control parameters deviate from the intended operating range and will allow for remote shutdown under emergency conditions. Trend analysis will aid in evaluating the performance (e.g., drift) of the instruments, indicating the need for maintenance or calibration.

Monitoring and metering locations and frequencies are summarized in Table 6 below.

Table 6—Continuous Monitoring Methods and Frequency

Objective	Method	Minimum sampling frequency	Minimum recording frequency
Injection pressure and temperature at surface	Surface gauges installed on injection line near wellhead	One second	30 seconds
Injection rate and volume	Mass flow meter on injection line near wellhead	One minute	One hour
Injection pressure and temperature downhole	Downhole tubing-deployed gauge above packer ported to tubing above packer	10 seconds	30 seconds
	DTS fiber	10 minutes	30 minutes
Pressure on the annulus between the tubing and long string casing	Downhole tubing-deployed gauges ported to annulus above packer	10 seconds	30 seconds
Annular pressure at surface	Pressure gauge installed in wellhead	One second	30 seconds
Annulus volume	Continuous pressure monitoring between tubing and production casing, and continuous monitoring of pressure at surface to confirm absence of leakage. Direct fluid level measurements may also be obtained, as triggered by pressure data.	10 seconds pressure gauge; fluid level as needed	30 seconds on pressure gauge, fluid level as needed

3.2 Description of Methods and Justification

3.2.1 Pressure and Temperature Monitoring

OLCV will monitor and measure injection pressure and temperature (P/T) three ways in the Injector well: downhole gauges, DTS and surface gauges. One P/T gauge will be installed downhole as part of the completion and ported into the tubing to continuously measure CO₂ injection P/T. The downhole sensor will be the point of compliance for maintaining injection pressure below 90% of formation fracture pressure.

A second P/T gauge will be installed on the outside of the tubing string above the packer to measure pressure continuously in the annular space above the packer and identify any potential loss of mechanical integrity.

At the surface, electronic pressure gauges and temperature sensors will be used to continuously monitor the pressure and temperature of the annulus between the tubing and long string casing. Gauges and sensors will be connected to the automation system to provide continuous data analysis as well as alarms for malfunctioning events when the values deviate from the intended operating range.

If the downhole gauges stop working between scheduled maintenance events, then the surface pressure limitation approved for this permit will be used as a backup until the downhole gauges are repaired or replaced. For calibration purposes, in lieu of removing the injection tubing, the accuracy of the downhole gauges will be demonstrated by using a second pressure gauge with current certified calibration lowered into the well at the same depth as the permanent downhole gauge.

In addition to gauges, fiber optic cable will be attached along the side of the casing and to a distributed temperature sensing (DTS) interrogator on the surface, which will provide a distributed temperature profile while injecting. This system will record temperature continuously to aid in monitoring the CO₂ behavior and detect any unforeseen mechanical integrity issue in the well.

3.2.2 Injection Rate and Volume Monitoring

The mass flow rate of CO₂ injected into the well will be measured using flowmeter skids with Coriolis meter in the CO₂ injection line near the interface with the wellhead, shown as FE-100 in Figure 4. Piping and valving will be configured to permit flowmeter calibration. A redundant pressure control valve will be installed to allow for continuous injection during routine maintenance of the device. The flow transmitter will be connected to a remote terminal unit (RTU) on the flowmeter skid.

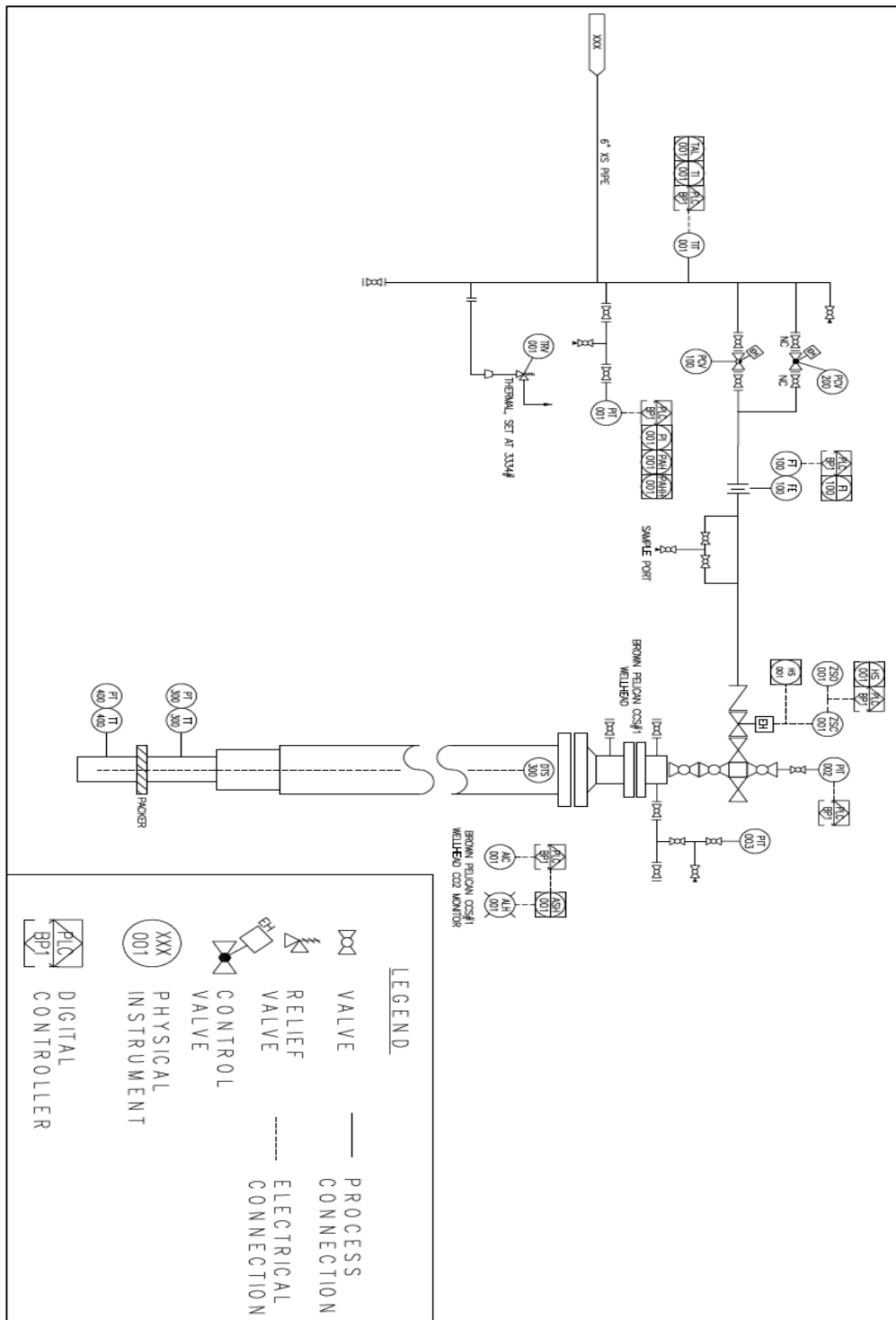

Figure 4—Representative example of wellhead process and instrumentation diagram

The process control system will limit the wellhead pressure to 1,800 psig to protect the surface equipment.

The project will follow the equations from 40 CFR Part 98-Subpart RR for CO₂ mass calculation.

4.2.3. Packer fluid / Annulus Volume Monitoring

The initial volume of packer fluid to fill the casing will be measured prior to the commencement of injection operations. Annular pressure will be kept between 100 and 400 psi on surface, and pressure data obtained from surface gauges and downhole gauges will be used to confirm the absence of unexpected changes in annulus volume. In addition, if there are changes in pressure, OLCV will conduct fluid level measurements to further confirm annulus fluid volume. This methodology will allow the operator to confirm the variation in annular fluid due to temperature changes v. potential mechanical integrity issues.

4.2.4. Justification of Continuous Monitoring Methods and Backup Options

Multiple measurements of P/T will be collected in the Injector wells to provide confidence in the data. Downhole and surface gauges are routinely used in well operations and have historically performed to expectation over the operational life of the well. DTS technology is relatively newer in operational deployment, thus its long-term performance history is less constrained. If DTS fails before the end of the monitoring period, gauges will be utilized to meet monitoring requirements.

In the event anomalous measurements are obtained from the P/T gauges or from DTS data, the gauges and wellhead will be manually inspected. Maintenance or repair operations on the instruments will commence, if required. If anomalous measurements are detected to be different between the gauges or DTS, an investigation into the cause will be conducted. OLCV will conduct appropriate repairs or adjustments and re-collect data.

The injection rate and volume metering protocols to be used at BRP follow the prevailing industry standard(s) for custody transfer as currently promulgated by the American Petroleum Institute (API), the American Gas Association (AGA), and the Gas Processors Association (GPA), as appropriate. This approach is consistent with EPA GHGRP's Subpart RR, section 98.444(e)(3). These meters will be maintained and calibrated routinely, operated continually, and will feed data directly to the centralized data collection systems. The meters meet the industry standard for custody transfer meter accuracy and calibration frequency.

4.0 Corrosion Monitoring and Surface Leak Detection

To meet the requirements of 40 CFR §146.90(c), OLCV will monitor well materials during the operation period for loss of mass, thickness, cracking, pitting, and other signs of corrosion to ensure that the well components meet the minimum standards for material strength and performance.

Materials (Table 7) have been selected to mitigate and inhibit corrosion. The suitability of the materials has been determined with published performance data from materials suppliers. A summary of materials is listed below. These materials will be monitored via coupons that will be exposed to the CO₂ injectate stream and reservoir fluids.

Table 7—List of Equipment with Construction Materials in Pipeline, Injectors, Injection Zone monitor and water withdrawal wells

Equipment Coupon	Construction Material
Pipeline	Carbon steel
Long string casing <i>above Injection Zone</i> in injection wells and Injection Zone monitoring and water withdrawal wells	Carbon steel, L80
Long string casing <i>in Injection Zone</i> in injection wells	Carbon steel coated, Super Duplex 2507 SS, #17, 80kpsi
Long string casing <i>in Injection Zone</i> for Injection Zone monitoring and water withdrawal wells	Carbon Steel, L80
Tubing <i>above packer</i> in injection wells	Coated carbon steel, L80, Coated TK-805
Tubing for Injection Zone monitoring and water withdrawal wells	Coated carbon steel, L80, Coated TK-805
Wellhead for injection wells, Injection Zone monitoring and water withdrawal wells	Alloy Steel DD specification
Injection tree and tubing hanger for injection wells	Sour service HH specifications
Packers for injection wells and Injection Zone monitoring and water withdrawal wells	Nickel-plated / HNBR (RGD) elastomers

4.1 Monitoring Location and Frequency

Corrosion monitoring of the CO₂ injection wells and water withdrawal wells will be conducted

in a surface monitoring spool located near the wellhead that contains multiple access points. To measure corrosion, coupons or probes composed of well materials will be inserted at the access points in the spool, and those coupons or probes will be exposed to fluids being injected or produced from the wellbores. For Injection Zone and Confining Zone monitoring wells, a monitoring spool will be placed at the wellhead that is open to the tubing to monitor corrosion of the fluids/gas in the tubing. Coupons/probes will be collected and sent to a third-party company for analysis in accordance with NACE Standard SP-0775-2018-SG on a quarterly basis during the Injection Period and until wells are plugged in the post-injection period. Note that CO₂ is not expected to be encountered in the water withdrawal wells or in Confining Zone monitor wells.

In addition to coupons, OLCV will conduct visual inspection of the facilities, utilize optical gas imaging cameras (OGI), and evaluate data from DTS to monitor for potential leakage that could result from corrosion.

In the event that OLCV collects data that are consistent with possible corrosion, OLCV will re-conduct a visual inspection of the facilities, physical inspection using nondestructive techniques, re-collect data from coupons or optical gas imaging. In the event that corrosion is confirmed, OLCV will assess equipment fitness for service and take appropriate remediation actions.

Casing inspection logging will be conducted during planned well maintenance operations to evaluate downhole conditions and confirm absence of corrosion.

Table 8 provides a summary of the corrosion monitoring methods.

Table 8—Corrosion Monitoring and Surface Leak Detection Summary

Objective	Method	Pre-Injection	Injection	Post-Injection
Identify material corrosion in flowline and wellbore	Corrosion coupons	N/A	Quarterly	N/A
	Casing inspection log	Caliper cased hole log prior to injection operations	During planned well maintenance	N/A
Identify loss of mechanical integrity that could lead to corrosion	DTS	Prior to injection	Continuously	N/A
Surface monitoring and leak detection	Visual inspection and portable monitors	Prior to injection	Weekly	N/A
	OGI camera	Prior to injection	Quarterly	N/A
	CO2 surface sensors	Prior to injection	Continuously	N/A

4.2 Description of Methods and Justification

4.2.1 Corrosion Coupons

Samples of injection well materials (coupons) will be exposed to the injected CO₂ stream and monitored for signs of corrosion to verify that the well components meet the minimum standards for material strength and performance and to identify well maintenance needs. Coupons will be placed in a tray near the gas chromatograph / gas analyzer that is used to monitor the CO₂ injectate stream in the flowline. The coupon location will be safe and easily accessible for the vendor to retrieve. Coupons will be analyzed by a third party in accordance with NACE Standard SP-0775- 2018-SG to determine and document corrosion wear rates based on mass loss. A summary of coupon parameters is shown in Table 9

Table 9—Summary of Analytical Parameters for Corrosion Coupons

Parameters	Analytical Method	Resolution Instruments	Precisions/Std Dev
Mass	NACE SP0775-2018-SC	0.05 mg	2%
Thickness	NACE SP0775-2018-SC	0.01 mm	± 0.05 mm

NACE SP0775-2018-SC: Preparation, Installation, Analysis, and Interpretation of Corrosion Coupons in Oilfield Operations

Coupon data will be evaluated by OLCV engineers to confirm that well components meet the standards for material strength and performance. Appropriate corrective action will be taken if needed to restore the well components to meet operational standards.

5.2.2. Casing Inspection Logs

OLCV intends to perform casing inspection logging (CIL) during planned well maintenance. Between planned maintenance events, OLCV may conduct a CIL, if corrosion coupon data indicates potential loss of material strength or performance inconsistent with operating standards.

5.2.3. Surface detection methods

Field personnel will visit the Project location on a routine, at least weekly, basis to make observations of surface equipment, identify potential leaks, and verify that equipment is operating within design limits. Field personnel will be provided with handheld equipment to identify the presence of CO₂ as part of the safety requirements for the site.

Additional, quarterly, optical analysis using OGI cameras will be performed during the injection period. OGI cameras are highly specialized cameras that provide a method to spot invisible gases as they escape. These cameras rely on infrared images to detect the leaks and they will be used during the inspection of facilities, pipelines, and well locations.

5.0 Monitoring the Injection Zone

Injection-zone monitoring of pressure and temperature, saturation, and chemistry of fluids and dissolved gasses will be conducted to directly confirm the presence or absence of CO₂ at the monitoring well locations.

5.1 Monitoring Location and Frequency

The Lower San Andres Injection Zone will be directly monitored using the SLR2 and SLR3 monitoring wells. The SLR2 will be drilled prior to the commencement of CO₂ injection and will be located within the maximum extent of the pressure front resulting from CO₂ injection. The SLR3 well will be drilled within five years after CO₂ injection commences.

The Injection Zone will be indirectly monitored by the Shoe Bar 1 stratigraphic test well that will be plugged above the Injection Zone prior to the commencement of CO₂ injection. The portion of the well above the Injection Zone contains DTS/DAS fiber that may be used during VSP seismic acquisition and for monitoring pressure and temperature above the confining zone and indirectly informing containment in the Injection Zone.

Table 10—Monitoring of the Injection Zone

Objective	Method	Frequency pre-injection	Frequency during injection	Frequency post-injection
Pressure and temperature monitoring downhole	Downhole gauge ported to tubing and ported to annulus in injection wells	Prior to injection	Continuously, 10 second sampling and 5 minute recording frequency	Continuously for the first 10 years pending an approved PISC plan then annually until plugging; 10 second sampling and 5 minute recording frequency
	DTS (planned for SLR2 and possibly SLR3)	In SLR2, prior to injection	Continuously, 10 minute sampling and 30 minute recording frequency	Continuously for the first 10 years pending an approved PISC plan, then annually until plugging; 10 minute sampling and 30 minute recording frequency
Pressure and temperature monitoring at surface	Surface gauge at injection well wellhead	Prior to injection	Continuously, 1 second sampling and 30 second recording frequency	Continuously for the first 10 years pending an approved PISC plan, then annually until plugging; 1 second sampling and 30 second recording frequency
Saturation profile	PNL or RST logging in SLR2 and SLR3 and WWs	In SLR2, prior to injection	Annually in SLR2 and SLR3; event-driven* in WWs	Annually until plugging

Fluid and dissolved gas geochemistry	Fluid and dissolved gas sampling and analysis in SLR2 and SLR3	During construction of injector wells, SLR wells and WWs and prior to injection to establish characterization	In SLR2 and SLR3, or WWs; Event-driven*, triggered by P/T data	Event-driven*, triggered by P/T data
--------------------------------------	--	---	--	--------------------------------------

*OLCV will monitor pressure and temperature data obtained from downhole gauges and/or DTS fiber daily, and also routinely evaluate long-term data trends to detect deviations from the reference temperature or pressure gradient. If persistent deviations in temperature or pressure are detected, OLCV will obtain reservoir fluid samples and analyze fluid and dissolved gas chemistry to determine the presence or absence of increased CO₂. Saturation logging may also be conducted to further support or refute the presence of increased CO₂.

6.2 Description of Methods and Justification

Pressure and temperature downhole and surface gauges will be installed in the SLR2 and SLR3. See Section 1.4.7 in QASP for description of gauges. In addition, the SLR1 well includes DTS fiber that will be used for indirectly monitoring the Injection Zone.

A pulsed neutron log (PNL) or other saturation log (RST) will be collected in the SLR2 and SLR3 wells annually. This log is collected in cased holes and can be used to solve for water, oil, and gas saturations. Saturation logging may also be conducted in water withdrawal wells: WW1, WW2, WW3 and WW4.

Fluid and dissolved gas samples were collected while drilling the SLR1, ACZ1, WW1, WW2, WW3, and WW4 and will be collected in the future BRP CCS1, BRP CCS2, BRP CCS3, SLR2 and SLR3 wells. Additional fluid and dissolved gas samples will be conducted to constitute a baseline. These samples will be analyzed for their geochemical composition and isotopic characterization. If anomalous pressure and temperature changes are observed in an SLR well during injection or post-injection, fluid samples and/or dissolved gas samples will be obtained for geochemical and isotopic analyses and comparison with pre-injection samples.

7.0 Monitoring the First Permeable Zone Above the Confining Zone

The first permeable zone above the confining zone is the Santa Rosa formation, which is the lowermost member of the Dockum group. It will be monitored with the USDW1 well, a dedicated well that is located close to the BRP CCS1 and BRP CCS2 injection sites. Together

with shallow groundwater and near-surface monitoring (See Section 8 of this document), OLCV will monitor groundwater quality and geochemical changes above the confining zone during the operation period to meet the requirements of 40 CFR §146.90(d). The results of ground water sampling will be compared to baseline geochemical and isotopic data collected during the site characterization baseline, consistent with 40 CFR §146.82(a)(6), to obtain evidence of potential fluid or gas movement.

7.1 Monitoring Location and Frequency

The zone of highest pressure, and thus highest potential for fluid movement, is close to the injection wells. The USDW1 well will monitor for potential loss of containment through the confining layers. Because the size of the BRP plume is expected to remain small (<6 miles²), OLCV models that one well is sufficient to monitor above the confining zone. Additional monitoring wells for the USDW may be drilled in the future, depending on the shape and location of the CO₂/pressure plume.

The integrity of the Upper Confining Zone will also be monitored by the Shoe Bar 1 and/or Shoe Bar 1AZ stratigraphic test wells that will be plugged above the Injection Zone prior to the commencement of CO₂ injection. Saturation logging (PNL or RST) will be conducted in the wells in the intermediate hole section including the Grayburg and Upper San Andres formations. PNL and RST logs yield less reliable data through three casing strings, therefore, this method will not be appropriate for monitoring saturation in the lowermost USDW.

Monitoring above the confining zone is summarized in Table 11.

Table 11—Monitoring above the Injection Zone

Objective	Method	Frequency pre-injection	Frequency during injection	Frequency post-injection
First Permeable zone above the confining zone / lowermost USDW: Dockum				
Fluid and dissolved gas geochemistry in the first permeable zone above the confining zone	Fluid and dissolved gas sampling and analysis in USDW1	During construction and quarterly during baseline	Quarterly geochemical sampling in years 1-3 and annually starting in year 4; and event-driven*, triggered by P/T in SLR wells or soil gas chemistry	Annually for first 10 years pending an approved PISC plan; and event-driven*, triggered by P/T in SLR wells or soil gas chemistry
Upper Confining Zone integrity				
Estimate CO2 saturation in the Upper Confining Zone	PNL or RST in SLR1 and ACZ1	Prior to injection	Every five years	Event-driven*
Pressure and temperature in the Upper Confining Zone	DTS in SLR1	Prior to injection	Continuous measurement and recording of pressure and temperature	Event-driven*

*OLCV will monitor pressure and temperature data obtained from downhole gauges and/or DTS fiber daily, and also routinely evaluate long-term data trends to detect deviations from the reference temperature or pressure gradient. If persistent deviations in temperature or pressure are detected, OLCV will obtain reservoir fluid samples and analyze fluid and dissolved gas chemistry to determine the presence or absence of increased CO₂. Saturation logging may also be conducted to further support or refute the presence of increased CO₂.

7.2 Description of Methods and Justification

See Section 8.1 for details on fluid sampling and analyses.

8.0 Monitoring the Near-Surface

The primary objectives of the near-surface monitoring program are to confirm containment of CO₂ within the Lower San Andres Injection Zone, demonstrate protection of the deepest USDW, and to provide for early detection of anomalous conditions indicative of potential leakage of CO₂ or of brine migration. Water composition in shallow wells and soil gas within the near-surface has considerable variation due to natural processes and naturally occurring events and due to anthropogenic processes unrelated to the Project. Such natural and anthropogenic variation increases the difficulty of using only composition as the baseline for CO₂ leak and brine migration monitoring purposes. Instead, characterization of the subsurface system, including near-surface conditions (i.e., soil gas, fluid and dissolved gas chemistry of the deepest USDW; Section 7.0), and target injection reservoir fluids (see discussion in Section 6.0), provides a better approach for identifying unique tracers in the system that will potentially help identify an anomalous change in condition, and if needed, the source of the changes and discard false positives associated with potential CO₂ leaking or brine migration from the storage complex.

For the BRP Project, the lowermost USDW and soil gas within the AoR will be monitored in accordance with 40 CFR §146.90(d) and 40 CFR §146.90(h), respectively, and at the frequencies specified in Table 12.

Table 12—Monitoring the Near-Surface

Objective	Method	Frequency pre-injection	Frequency during injection	Frequency post-injection
Fluid and dissolved gas geochemistry in the lowermost USDW	Fluid and dissolved gas sampling and analysis	During construction and quarterly during baseline	Quarterly geochemical sampling in years 1-3 and annually starting in year 4; and event-driven*, triggered by P/T in SLR wells or soil gas chemistry	Annually for first 10 years pending an approved PISC plan; and event-driven*, triggered by P/T or soil gas chemistry
Soil gas analysis in the near-surface vadose zone	Isotopic analysis and chemical evaluation at approximately 21 locations	Characterization prior to injection, including quarterly sampling for at least one year	Quarterly gas composition sampling in years 1-3 and annually starting in year 4 for subset of stations, and event-driven*, triggered by P/T data in SLR wells and fluid sample results	Event-driven*, triggered by P/T data in SLR wells and fluid sample results

* OLCV will monitor pressure and temperature data obtained from downhole gauges and/or DTS fiber daily, and also routinely evaluate long-term data trends to detect deviations from the reference temperature or pressure gradient. If persistent deviations in temperature or pressure are detected, OLCV will obtain reservoir fluid samples and analyze fluid and dissolved gas chemistry to determine the presence or absence of increased CO₂. In addition, fluid and dissolved gas chemistry data from the lowermost USDW and soil gas chemistry from shallow soils will be monitored for trends to detect deviations from reference chemistry. If persistent and/or abrupt anomalies in chemistry are detected additional fluid or soil gas samples will be obtained to confirm the presence or absence of increased CO₂.

8.1. USDW Sampling

8.1.1 Monitoring Location and Frequency

The Project has drilled one well to monitor the Dockum group (i.e., Shoe Bar 1USDW or USDW1).

The monitoring well is located close to the proposed BRP CCS1 and BRP CCS2 locations.

Note that one existing USDW-level well (Serial No. 4511701) was drilled in 1940. This well was located in the AoR during the evaluation of artificial penetrations and was determined to have low mechanical integrity. The 4511701 well was plugged and abandoned using hydrated Baroid 3/8" bentonite hole plug chips from 189 ft bgs to 5ft bgs and a cement slurry to the ground surface. There are no other existing USDW-level wells within the AoR.

Fluid and dissolved gas samples were collected after the installation and adequate development of the Shoe Bar 1USDW. Additional samples will be collected quarterly for at least one year prior to commencement of injection. Quarterly sampling commenced in June 2024. These samples will be analyzed for their geochemical and isotopic characterization shown in Table 13. After injection commences, Shoe Bar 1USDW will be sampled for geochemical analysis and a subset of the isotopic analyses at a quarterly frequency in years one to three, then annually starting in the fourth year after commencement of injection until the end of injection period. During the post-injection phase of the Project, the USDW will be monitored annually for geochemical analysis and a subset of the isotopic characterization for the first 10 years. If anomalous soil gas chemistry is observed, anomalous pressure and temperature changes are observed a SLR well, or there is any indication of leakage through the injection wells during the injection and post-injection phases of the Project, additional fluid samples may be obtained for geochemical and isotopic analysis and comparison to pre-injection sample results. If geochemistry data of fluids and dissolved gasses in the lowermost USDW are consistent with the absence of introduced Injection Zone brine or CO₂ injectate into the USDW, this monitoring method will be discontinued after 10 years post injection.

8.1.2. Description of Methods and Justification

The purpose of monitoring above the confining zone is to identify potential geochemical changes due to the introduction of CO₂ injectate stream or displaced formation fluids above the primary confining zone. Unlike some injected materials regulated by UIC, the presence of CO₂ in groundwater, surface water or soils may be the result of naturally occurring biological processes. Therefore, the presence of CO₂ in shallow or surface intervals is not necessarily diagnostic of leakage from an Injection Zone (Romanak, 2012). Furthermore, it may be impossible to establish a meaningful baseline CO₂ concentration, because the concentration of CO₂ in soils and groundwater is changing overtime due to global climatic changes (Bond-Lamberty, 2010; Macpherson, 2008; and Burger, 2020). However, the monitoring plans for the BPR project is designed to establish observable trends to characterize variabilities and changes due to natural processes and anthropogenic sources during the baseline phase of the Project.

In addition to establishing a baseline, OLCV plans to use a process-based approach along with natural tracers to characterize and attribute CO₂ measured in groundwater. The process-based approach involves characterizing groundwater prior to the commencement of injection operations. For the purpose of characterizing groundwater prior to injection while accounting for variations due to existing natural processes (and anthropogenic sources other than OLCV, if any), multiple samples will be collected during pre-injection activities. Similarly, multiple soil gas samples from across the AoR will be used to characterize the naturally-occurring variability across the site. See Section 8.2 in this document for more information on soil gas characterization.

For the process-based approach using natural tracers in groundwater, Romanak (2012) recommends characterizing $\delta^{13}\text{C}$, ^{14}C , CH₄, and δD in the fluids throughout the stratigraphic column. These isotopes can be used to trace carbon reactions. The initial characterization is intended to define components that will be diagnostic for future monitoring. In order to attribute the source of CO₂ or other relevant compounds, isotopic characterization will also be performed on the injectate fluid, fluids from the Injection Zone, fluids in first permeable layer above the Injection Zone, and fluids and dissolved gasses from the USDW.

To monitor changes, Romanak (2014) suggests using the covariation of $\delta^{13}\text{C}$ and ^{14}C as natural tracers. $\delta^{13}\text{C}$ in anthropogenic sources overlaps the signature of naturally-occurring biologic sources, so the data should be considered in context with other lines of evidence. However, ^{14}C in CO₂ is interpreted to be diagnostic between anthropogenic and naturally-occurring sources. The BRP has a unique challenge in that the source of the CO₂ injectate is captured directly from the ambient air that may contain signatures of multiple anthropogenic sources rather than from a specific industrial anthropogenic source, thus the ability to use the variation of $\delta^{13}\text{C}$ and ^{14}C for attribution is not well-studied.

To support the interpretation of the isotopic characterization of the natural tracers such as the variation of $\delta^{13}\text{C}$ and ^{14}C , geochemical properties of the lowermost USDW fluid will be characterized and a baseline will be established. Geochemical changes in the Dockum group may occur after the inadvertent introduction of foreign fluids or gases to the aquifer through a leakage pathway or conduit (i.e., CO₂ and/or brine migration from the target injection formation) during the injection phase of the Project (EPA, 2013).

At the end of the pre-injection monitoring period, OLCV will establish geochemical and isotopic trends, including seasonal variations, which characterize the natural or existing conditions in the USDW. These trends will be used to create procedures for CO₂ and brine leakage identification and characterization in the Dockum group during the injection and

post-injection phases of the BRP.

The table below lists the components that will be characterized and monitored in the groundwater collected from the monitoring wells at BRP.

Table 13—Water Analysis Parameters

Laboratory Analyte	Analytical Methods ¹	Detection Limit / Range ²	Typical Precision ²	QC Requirements
<u>Total and Dissolved Metals:</u> Ag, Al, As, Ba, Cd, Co, Cr, Cu, Mn, Mo, Ni, Pb, Sb, Se, Sr, Th, Tl, U, V, and Zn	USEPA Method 200.8	0.00004 to 0.003 mg/L	±20	Daily calibration, Initial QC checks (ICV, ICB, RL) method blank, lab control samples, matrix spikes and sample duplicate, CCV/CCB every 10 samples or part thereof
Total and Dissolved Metals: B, Ca, Fe, K, Mg, Li, Na, Si, Sr, Ti	USEPA Method 200.7	0.003 to 0.254 mg/L	±20	Daily calibration, Initial QC checks (IPC, ICV, ICB, RL) method blank, lab control samples, matrix spike and matrix spike dup; CCV/CCB every 10 samples or part thereof
Total and Dissolved Hg	USEPA Method 245.7	19.6 ng/L	±20	Calibration as needed, daily QC checks; ICV, ICB, RL, method blank, lab control samples, matrix spike and matrix spike dup; CCV/CCB every 10 samples or part thereof
Dissolved Inorganic Carbon (DIC); Dissolved Organic Carbon (DOC)	Standard Method 5310C	0.198 to 0.290 mg/L	±20	Calibration as needed, daily QC checks; ICV, ICB, RL, method blank, lab control samples, matrix spike and matrix spike dup; CCV/CCB every 10 samples or part thereof

Dissolved CO ₂	Standard Method 4500 CO ₂ D	8 mg/L	±20	Frequent calibration, method blank, lab control samples, matrix spikes and sample duplicate.
Alkalinity: Total, Bicarbonate, Carbonate, and Hydroxide	Standard Method 2320B	8 mg/L	±20	method blank, lab control samples, matrix spikes
Major Anions: Br, Cl, F, and SO ₄ , NO ₂ and NO ₃ as N	USEPA Method 300.0	0.003 to 0.563 mg/L	±20	Calibration as needed, daily QC checks; ICV, ICB, RL, method blank, lab control samples, matrix spike and matrix spike dup; CCV/CCB every 10 samples or part thereof
PO ₄ as P	USEPA Method 365.1	0.0215 mg/L	±20	Daily calibration, Initial QC checks (ICV, ICB, RL) method blank, lab control samples, matrix spikes and sample duplicate, CCV/CCB every 10 samples or part thereof
Dissolved H ₂ S (Sulfide)	Standard Method 4500S2-D	0.026 mg/L	±20	Calibration as needed, daily QC checks; ICV, ICB, RL, method blank, lab control samples, matrix spike and matrix spike dup
Total Dissolved Solids (TDS)	USEPA Method 160.1	10 mg/L	±20	Method blank, lab control samples, and sample duplicate
Conductivity	Standard Method 2510B	0 to 200 mS/cm	±1%	Calibration as needed, daily QC checks (1413, 14130 and second source SRM), CCV every 10 samples or part thereof
pH and Temperature	USEPA Method 150.1	0.1 to 14 pH units	±0.1 pH units	Daily calibration, second source SRM, CCV's every 10 samples or part thereof

Specific Gravity	ASTM Method D1429-03	NA	To the nearest thousandths decimal	Duplicates
Cation Anion Balance	Calculation	NA	±10	Calculation
Dissolved Gas Abundances: CO ₂ , CO, N ₂ , Ar, He, H ₂ , O ₂ , C1-C6+	In-house Lab SOP, similar to RSK-175	1 to 100 ppm, varies by component	C1-C4: ± 5%; C5-C6+: ± 10%	20% of all analyses are check/reference standards.
Dissolved Gas Isotopes: δ ¹³ C of C1-C5 and CO ₂ , δ ² H of C1	High precision (offline) analysis via Dual Inlet IRMS	Varies by component	δ ¹³ C: 0.1 per mil; δ ² H: 3.5 per mil	20% of all analyses are check/reference standards.
¹⁴ C of C1	AMS - subcontracted to Beta Analytic	0.44 pMC	± 1 to 2 pMC	Daily monitoring of instrumentation and chemical purity in addition to extensive computer and human cross-checks.
¹⁴ C of DIC	AMS - subcontracted to Beta Analytic	Depends on available sample volume	± 1 to 2 pMC	Daily monitoring of instrumentation and chemical purity in addition to extensive computer and human cross-checks.
δ ¹³ C of DIC	Gas Bench/CF-IRMS	Depends on available sample volume, minimum of 50mg/L required	0.20 per mil	20% of all analyses are either check/reference standards or duplicate analyses.
δ ¹⁸ O and δ ² H of H ₂ O	Analyzed via CRDS	N/A	δ ¹⁸ O: 0.10 per mil; δ ² H: 2.0 per mil	20% of all analyses are either check/reference standards or duplicate analyses.

$^{87}\text{Sr}/^{86}\text{Sr}$	TIMS - subcontracted to the University of AZ	Approximately 40 ppm	± 0.00002	SRM 987 Sr standard within the long-term precision (external precision) of ± 0.00002 accepted value of 0.71025
$^{228}\text{Ra}/^{226}\text{Ra}$	USEPA Method 901.1	50 pCi/L (RL)	$\pm 25\%$	Frequent calibration, method blank, lab control samples, matrix spikes and sample duplicate.
Field Parameters				
pH (Field)	Standard Method 24500- H+ B-2000	2 to 12 pH units	± 0.2 pH units	User calibration per manufacturer recommendation
Specific conductance (Field)	EPA Method 120.1	0 to 200 mS/cm	$\pm 1\%$	User calibration per manufacturer recommendation
Temperature (Field)	Standard Method 2550 B-2000	-5 to 50 °C	± 0.2 °C	Factory calibration
Oxidation-Reduction Potential (Field)	Standard Method 2580	-1999 to +1999 mV	± 20 mV	User calibration per manufacturer recommendation
Dissolved Oxygen (Field)	ASTM Method D888-09 (C)	0 to 50 mg/L	0 to 20 mg/L: ± 0.1 mg/L or 1% of reading, whichever is greater; 20 – 50 mg/L: $\pm 8\%$ of reading	User calibration per manufacturer recommendation
Turbidity (Field)	USEPA Method 180.1	0 to 1000 NTU	$\pm 1\%$ of reading or 0.01 NTU, whichever is greater	User calibration per manufacturer recommendation
Laboratory Analyte	Analytical Methods¹	Detection Limit / Range²	Typical Precision²	QC Requirements

Total and Dissolved Metals: Ag, Al, As, Ba, Cd, Co, Cr, Cu, Mn, Mo, Ni, Pb, Sb, Se, Sr, Th, Tl, U, V, and Zn	USEPA Method 200.8	0.00004 to 0.003 mg/L	±20	Daily calibration, Initial QC checks (ICV, ICB, RL) method blank, lab control samples, matrix spikes and sample duplicate, CCV/CCB every 10 samples or part thereof
Total and Dissolved Metals: B, Ca, Fe, K, Mg, Li, Na, Si, Sr, Ti	USEPA Method 200.7	0.003 to 0.254 mg/L	±20	Daily calibration, Initial QC checks (IPC, ICV, ICB, RL) method blank, lab control samples, matrix spike and matrix spike dup; CCV/CCB every 10 samples or part thereof
Total and Dissolved Hg	USEPA Method 245.7	19.6 ng/L	±20	Calibration as needed, daily QC checks; ICV, ICB, RL, method blank, lab control samples, matrix spike and matrix spike dup; CCV/CCB every 10 samples or part thereof
Dissolved Inorganic Carbon (DIC); Dissolved Organic Carbon (DOC)	Standard Method 5310C	0.198 to 0.290 mg/L	±20	Calibration as needed, daily QC checks; ICV, ICB, RL, method blank, lab control samples, matrix spike and matrix spike dup; CCV/CCB every 10 samples or part thereof
Dissolved CO ₂	Standard Method 4500 CO ₂ D	8 mg/L	±20	Frequent calibration, method blank, lab control samples, matrix spikes and sample duplicate.
Alkalinity: Total, Bicarbonate, Carbonate, and Hydroxide	Standard Method	8 mg/L	±20	Method blank, lab control samples, matrix spikes

	2320B			
Major Anions: Br, Cl, F, and SO ₄ , NO ₂ and NO ₃ as N	USEPA Method 300.0	0.003 to 0.563 mg/L	±20	Calibration as needed, daily QC checks; ICV, ICB, RL, method blank, lab control samples, matrix spike and matrix spike dup; CCV/CCB every 10 samples or part thereof
PO ₄ as P	USEPA Method 365.1	0.0215 mg/L	±20	Daily calibration, Initial QC checks (ICV, ICB, RL) method blank, lab control samples, matrix spikes and sample duplicate, CCV/CCB every 10 samples or part thereof
Dissolved H ₂ S (Sulfide)	Standard Method 4500S2-D	0.026 mg/L	±20	Calibration as needed, daily QC checks; ICV, ICB, RL, method blank, lab control samples, matrix spike and matrix spike dup
Total Dissolved Solids (TDS)	USEPA Method 160.1	10 mg/L	±20	Method blank, lab control samples, and sample duplicate
Conductivity	Standard Method 2510B	0 to 200 mS/cm	±1%	Calibration as needed, daily QC checks (1413, 14130 and second source SRM), CCV every 10 samples or part thereof

pH and Temperature	USEPA Method 150.1	0.1 to 14 pH units	±0.1 pH units	Daily calibration, second source SRM, CCV's every 10 samples or part thereof
Specific Gravity	ASTM Method D1429-03	NA	To the nearest thousandths decimal	Duplicates
Cation Anion Balance	Calculation	NA	±10	Calculation
Dissolved Gas Abundances: CO ₂ , CO, N ₂ , Ar, He, H ₂ , O ₂ , C1-C6+	In-house Lab SOP, similar to RSK-175	1 to 100 ppm, varies by component	C1-C4: ± 5%; C5-C6+: ± 10%	20% of all analyses are check/reference standards.
Dissolved Gas Isotopes: δ ¹³ C of C1-C5 and CO ₂ , δ ² H of C1	High precision (offline) analysis via Dual Inlet IRMS	Varies by component	δ ¹³ C: 0.1 per mil; δ ² H: 3.5 per mil	20% of all analyses are check/reference standards.
¹⁴ C of C1	AMS - subcontracted to Beta Analytic	0.44 pMC	± 1 to 2 pMC	Daily monitoring of instrumentation and chemical purity in addition to extensive computer and human cross- checks.
¹⁴ C of DIC	AMS - subcontracted to Beta Analytic	Depends on available sample volume	± 1 to 2 pMC	Daily monitoring of instrumentation and chemical purity in addition to extensive computer and human cross- checks.
δ ¹³ C of DIC	Gas Bench/CF-IRMS	Depends on available sample volume, minimum of 50mg/L required	0.20 per mil	20% of all analyses are either check/reference standards or duplicate analyses.

$\delta^{18}\text{O}$ and $\delta^2\text{H}$ of H_2O	Analyzed via CRDS	N/A	$\delta^{18}\text{O}$: 0.10 per mil; $\delta^2\text{H}$: 2.0 per mil	20% of all analyses are either check/reference standards or duplicate analyses.
$^{87}\text{Sr}/^{86}\text{Sr}$	TIMS - subcontracted to the University of AZ	Approximately 40 ppm	± 0.00002	SRM 987 Sr standard within the long-term precision (external precision) of ± 0.00002 accepted value of 0.71025
$^{228}\text{Ra}/^{226}\text{Ra}$	USEPA Method 901.1	50 pCi/L (RL)	$\pm 25\%$	Frequent calibration, method blank, lab control samples, matrix spikes and sample duplicate.
Field Parameters				
pH (Field)	Standard Method 2450- H+ B-2000	2 to 12 pH units	± 0.2 pH units	User calibration per manufacturer recommendation
Specific conductance (Field)	EPA Method 120.1	0 to 200 mS/cm	$\pm 1\%$	User calibration per manufacturer recommendation
Temperature (Field)	Standard Method 2550 B-2000	-5 to 50 °C	± 0.2 °C	Factory calibration
Oxidation-Reduction Potential (Field)	Standard Method 2580	-1999 to +1999 mV	± 20 mV	User calibration per manufacturer recommendation
Dissolved Oxygen (Field)	ASTM Method D888-09 (C)	0 to 50 mg/L	0 to 20 mg/L: ± 0.1 mg/L or 1% of reading, whichever is greater; 20 – 50 mg/L: $\pm 8\%$ of reading	User calibration per manufacturer recommendation

Turbidity (Field)	USEPA Method 180.1	0 to 1000 NTU	± 1% of reading or 0.01 NTU, whichever is greater	User calibration per manufacturer recommendation
-------------------	--------------------	---------------	---	--

Notes:

¹An equivalent method may be employed with the prior approval of the UIC Program Director.

²Detection limits and precision (laboratory control limits) are typical for these analytical methods.

* Analytical parameters to be included during the pre-injection phase, and only as needed during the injection and post-injection phases of the Project.

Water samples in the Shoe Bar 1USDW will be collected in appropriate containers provided by the laboratories according to EPA best practices by a qualified and experienced third-party contractor(s) as described in the QASP. All sample containers will be labeled with a unique sample identification number and sampling date, written with durable labels and indelible markings. The water samples will be preserved appropriately, as required by the specific analytical methods, and shipped within 24 hours of collection to certified laboratories, under chain-of-custody control.

Groundwater analyses from the Dockum group will be performed by third-party laboratories accredited with the EPA and/or the Texas Commission on Environmental Quality (TCEQ), following the specific methods approved by EPA or alternative methods (e.g., ASTM Methods or Standard Methods). Operators might audit the procedures and results of the selected laboratories with a third party to review laboratory internal quality control procedures. The samples will be analyzed by a third-party laboratory using standardized procedures for various instruments including for gas chromatography, mass spectrometry, detector tubes, and photo ionization. Sampling methods and chain of custody procedures are described in the QASP.

OLCV personnel experienced in fluid geochemical and isotopic analyses will evaluate the analytical reports provided by the laboratories who analyzed the fluid samples. These data will be compared with previous measurements to look for trends or changes in chemical composition. Groundwater results will be evaluated along with pressure and temperature data to determine the presence or absence of Injection Zone fluid or fluid migration above the confining zone.

An anomalous detection of CO₂ above background levels in the USDW “does not necessarily

demonstrate that USDWs have been endangered, but it may indicate that a leakage pathway or conduit exists” (EPA, 2013b). Therefore, if it is determined that a departure between observed and baseline parameter patterns appears to be related to a potential CO₂ leak from the target reservoir, additional testing of the USDW may be conducted. If OLCV personnel interpret that fluids or gases from the Injection Zone may be leaking into permeable zones above the confining zone, the source of the potential leak will be investigated, and appropriate corrective actions will be taken to protect the drinking water resources within the AoR.

The elements of the USDW monitoring program may be modified throughout the baseline, injection, and post-injection operational phases of the project, as needed, and with approval of the Director, as more data and information become available for the Project.

8.2. Near-Surface Soil and Soil Gas Sampling

8.2.1 Monitoring Location and Frequency

The collection of soil gas data within the AoR will aid in the identification, characterization, and source-attribution of CO₂ encountered in the near-surface. The evaluation of near-surface data is complicated by the variations in natural processes in the vadose zone (e.g., root respiration, biologic respiration, microbial oxidation of methane), anthropogenic sources unrelated to the BRP (e.g., nearby oil and gas production), gases from deeper zones (e.g., shallow groundwater), and atmospheric exchanges driven by barometric differences, which can be seasonal (NETL, 2017). As stated by the EPA (2023b), background soil CO₂ concentrations and isotopic compositions are largely “dependent on exchange with the atmosphere, organic matter decay, uptake by plants, root respiration, deep degassing, release from groundwater due to depressurization, and microbial activities.” Therefore, some component of soil gas monitoring during the baseline phase of the project is useful to i) define the baseline molecular and isotopic compositions of the shallow soil gas, and ii) characterize natural background variability, including seasonal trends. The results of the pre-injection soil gas monitoring may then be used for future reference and comparison to operational soil gas monitoring to assist in the detection, validation, and quantification of potential CO₂ leakage. To this end, a soil gas monitoring program will be conducted during pre-injection and injection utilizing permanent soil gas probes as an active, whole air, sample collection method.

Permanent subsurface soil gas probes will be installed at 21 representative locations throughout the surface projection of the AoR and adjacent DAC facility. Installation commenced in June 2024 and will extend through July 2024. The following factors were considered in siting soil gas probes: the location of artificial penetrations discussed the Area

of Review and Corrective Action Plan; variable surface soil characteristics, such as caliche deposits; the potential effects of the Direct Air Capture (DAC) facility on natural processes in the near-surface; and the location of adjacent property owners. Three probe stations are located near the proposed injection wells, where highest pressures and risks of vertical migration are expected. One probe station is located near each artificial penetration within the AoR (i.e., the BRP verification/monitoring wells and heritage wells). Two probe stations are located near the DAC facility and three probe stations are located along the southern boundary of the Shoe Bar Ranch property boundary near the adjacent private property.

Soil gas samples are collected after the installation of probes. Additional soil gas samples will be collected on a quarterly basis before beginning CO₂ injection over a period of at least one year. These samples will be analyzed for geochemical and isotopic composition shown in Table 14 to evaluate and characterize the near-surface conditions prior to injection. After CO₂ injection commences, the soil gas probe stations will be sampled quarterly for gas composition analysis between year one to three, then a subset of the soil gas stations will be strategically selected based on the previous data collected and sampled annually starting in year four for gas composition analysis. In addition, during the injection and post-injection phases of the Project, if anomalous pressure and temperature changes are observed in the SLR wells, or there is any indication of CO₂ leakage through the injection well, additional soil gas samples may be collected for gas composition and/or isotopic analysis and comparison to pre-injection sample results or deeper zone fluid analysis results.

The elements of the soil gas monitoring program may be modified throughout the pre-injection and injection phases of the Project, as needed, as more data and information become available for the Site.

8.2.2 Description of Methods and Justification

Soil gas characterization and monitoring will be used in concert with fluid analyses to conduct a process-based approach according to the principles described in Romanak (2012). The process-based approach is based on the observation that for every one volume percent of O₂ that is utilized by a microbe during respiration, one volume percent of CO₂ is produced. This relationship of O₂ to CO₂ forms a respiration trend line. Samples that plot to the left of the respiration line indicate natural biological processes. Samples that plot to the right of the respiration line indicate that excess CO₂ has entered the soil (see Figure 5). The source of the excess CO₂ could potentially be attributed to leakage from an injection site, or leakage from a geologic source such as the mantle, or an anthropogenic source other than the OLCV Project.

In addition, Romanak (2012) suggests that using the ratio of N₂ to CO₂ (Figure 5) can be used to detect anomalous introductions of CO₂ into a system. An increase in CO₂ can result in relative dilution of N₂ in percent gas concentration. This relative reduction in N₂ may indicate a deviation from the natural signal and could be result of CO₂ leakage. In the cases of CO₂ v. O₂ and CO₂ v. N₂, the naturally-occurring ratios are consistent despite seasonal or longer-term variability (Figure 5). Variability due to short or long term naturally occurring processes fall along the same trend, but at different points on the line.

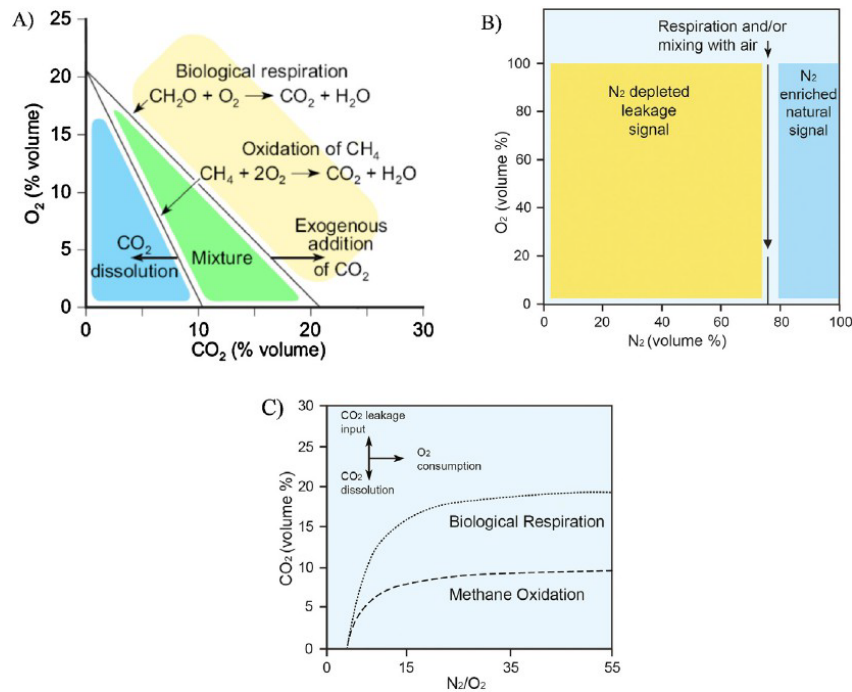

Figure 5—Process based approach for characterizing CO₂ source (modified Romanak, 2014)

As a result, the collection of soil gas samples for gas composition analysis can provide valuable information in the source attribution process for the presence of CO₂ and other gases in the vadose zone. However, the evaluation of the composition gas can be obscured in the light of the various biological processes present in the subsurface which produce or consume CO₂ (Romanak, 1997). Therefore, the collection and analysis of hydrocarbon gas as well as natural tracers ($\delta^{13}\text{C}$ and $\delta^{14}\text{C}$) can increase confidence in the interpretation of the data and the attribution of the CO₂ sources (i.e., natural vs. anthropogenic). Several studies have also demonstrated that analysis of soil gas for stable isotopes ($\delta^{13}\text{C}$ and δD) and hydrocarbons (C₂-C₃) can help determine whether the presence of the CO₂ and methane is due to natural biological processes or from thermogenic sources (e.g., reservoir deep gas) (Romanak, 2014).

Soil gas probe sites will be installed to a depth of approximately 10 feet below ground level, dependent upon the depth to shallow groundwater and presence of low-permeability (e.g., clay) zones, utilizing either a direct-push (e.g., GeoProbe®) or hand-auger drilling equipment. During borehole advancement, a continuous soil core will be collected and logged in accordance with Unified Soil Classification System (USCS) guidelines to determine soil type. Additionally, up to three soil samples per location will be collected in general accordance with EPA Method LSASDPROC-300-R5 (EPA, 2023a) for the laboratory analysis of pH, electrical conductivity, sodium adsorption ratio, total organic carbon (TOC), and soil moisture, in accordance with the methods specified in Table 14 below.

Table 14—Soil and Soil Gas Analysis Parameters

Parameter	Analytical Method
Soil Analyses	
pH	EPA Method 9045D
Electrical Conductivity (EC)	29B_EC
Sodium Adsorption Ratio (SAR)	29B_SAR
Total Organic Carbon (TOC)	Walkley Black 9060A
Moisture	SW3550
Soil Gas Analyses	
Composition gas: H ₂ , He, O ₂ , N ₂ , CO ₂ , CH ₄ , CO, Ar, C ₂ - C ₆ +	In-house Lab SOP, similar to RSK-175
*δ ¹³ C of CO ₂ and CH ₄	Gas chromatography/ combustion/ isotope ratio mass spectrometry
*C ¹⁴ of CO ₂	Accelerated mass spectrometry
*δD of CH ₄	Gas chromatography/ combustion/ isotope ratio mass spectrometry

Note:

* = Analytical parameters to be included during the pre-injection phase, and only as needed during the injection and post-injection phases of the project.

The installation of the permanent soil gas probes will be conducted in accordance with EPA operating procedure LSASDPROC-307-R5 (EPA, 2023b). To construct the soil gas monitoring stations, a drilling contractor will drill 2.25-in diameter boreholes to a depth up to 10 ft, depending on the thickness of the vadose zone and soil type encountered (Figure 6). Stainless-steel vapor implant points will be attached securely to 1/8th-inch Nylaflow® tubing and lowered to the bottom of the borehole. A sand pack using U.S. mesh interval 20/40 sand will be installed to approximately 6-inches above the vapor implant point as a filter pack. The remainder of the borehole will be backfilled with granular bentonite to the ground surface and hydrated to create an annular seal. The upper 1-foot of tubing will be encased within 1-inch diameter, schedule 40 polyvinyl chloride (PVC) pipe at the surface. The tubing will be

threaded through a drilled, tight-fitting PVC slip cap and sealed from atmospheric air utilizing a stainless-steel Swagelok® capping fitting. The tubing at the surface will be concealed within a 6-inch steel, flush mount manway, individually installed with a concrete pad, for protection and easy accessibility. General information for each sampling station location will be recorded, including project name, borehole designation, borehole total depth, date and time of completion, borehole GPS location information, soil gas probe construction, and field personnel information.

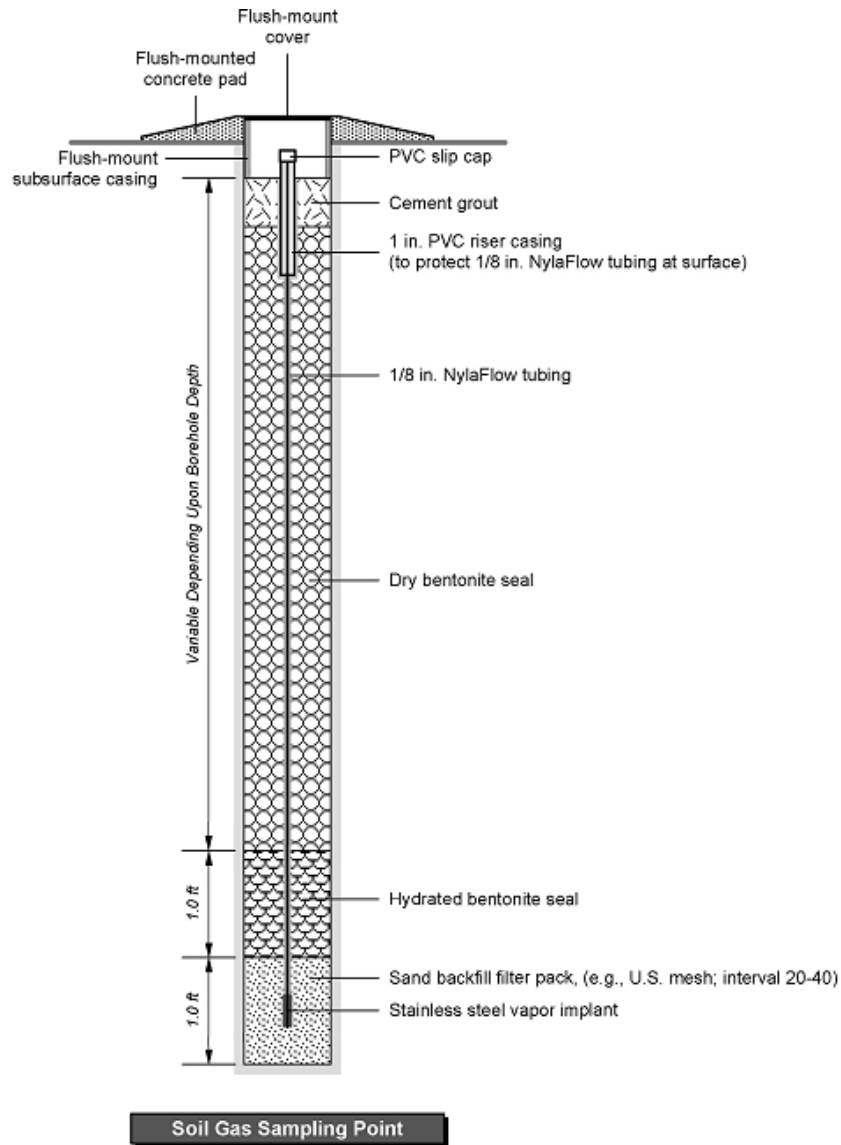

Figure 6—Soil gas probe installation diagram.

Permanent subsurface soil gas probes will be installed at approximately 21 representative locations throughout the surface projection of the AoR and adjacent DAC facility (Figure 7). The following factors will be considered in siting soil gas probes: the location of artificial penetrations discussed the Area of Review and Corrective Action Plan; variable surface soil characteristics, such as caliche deposits; the potential effects of the Direct Air Capture (DAC) facility on natural processes in the near-surface; and the location of adjacent property owners.

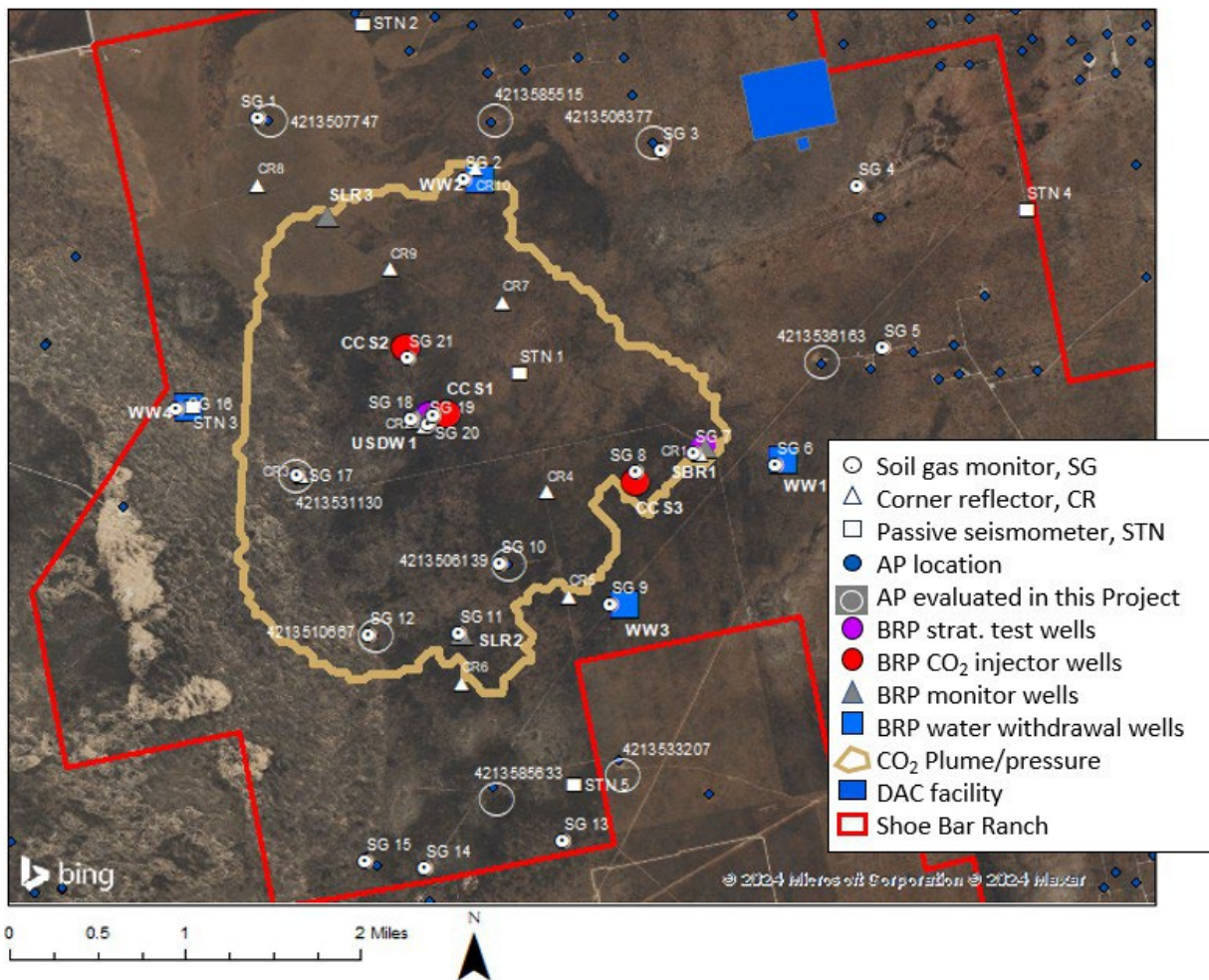

Figure 7—Approximate locations of soil gas monitoring stations and GPS station locations

Soil gas samples at the probe stations will be collected, generally following the procedures set forth in EPA Method SESDPROC-307-R5 (EPA, 2023b), by a qualified and experienced third-party contractor(s). During sample collection, a vacuum will be applied to the tubing on the surface using 60 mL gas-tight syringes, equipped with a 3-way valves, to first purge at least

the full length of the tubing, then collect a soil gas sample in appropriate sample containers provided by the laboratories. During soil gas sampling, a leakage test will be conducted by releasing helium gas as a tracer gas within a shroud over each soil gas sampling site. All sample containers will be labeled with a unique sample identification number and sampling date, written with durable labels and indelible markings. The soil and soil gas samples will be preserved appropriately, as required by the specific analytical methods, and shipped within 24 hours of collection to certified laboratories, under chain-of-custody control.

Soil and soil gas sample analyses will be performed by third-party laboratories accredited with the EPA and/or the TCEQ. Operators might audit the procedures and results of the selected laboratories with a third party to review laboratory internal quality control procedures. The samples will be analyzed by a third-party laboratory using standardized procedures for various instruments including gas chromatography, as further described in the QASP.

OLCV personnel experienced in soil analysis and gas composition and isotopic analysis and/or contractors will evaluate the analysis reports provided by the laboratories who analyzed the different samples. These results will be compared with previous measurements to look for trends or changes in chemical composition and distinguish major processes involved in the subsurface which impact the gas composition. The evaluation of soil gas composition and isotopic data will also be coupled with evaluation of other fluids samples, as well as pressure and temperature data to interpret the presence or absence of CO₂ from the Injection Zone or other gases indicated of leakage pathway from the reservoir.

As mentioned in Section 8.1, an anomalous detection of CO₂ above background levels in soil gas “does not necessarily demonstrate that USDWs have been endangered, but it may indicate that a leakage pathway or conduit exists” (EPA, 2013b). Therefore, if a departure from baseline/ seasonal parameter patterns is observed, additional testing of soil gas, the atmosphere, and/or the USDW may be conducted. If OLCV personnel interpret that fluids from the Injection Zone may be leaking into permeable zones above the confining zone and migrated to the vadose zone, the source of the potential leak will be investigated, and appropriate corrective will be taken to protect the drinking water resources within the AoR.

9.0 Internal and External Mechanical Integrity Testing

OLCV will conduct tests to verify the internal and external mechanical integrity of the Injector Wells before and during the injection phase pursuant to 40 CFR §146.89(c), 40 CFR §146.90(e), 40 CFR §146.87 (a)(2)(ii), and 40 CFR §146.87 (a)(3)(ii)].

The purpose of internal mechanical integrity testing is to confirm the absence of significant

leakage within the injection tubing, casing, or packers [40 CFR §146.89(a)(1)]. Continuous monitoring of injection pressure, injection rate, injected volume and annulus pressure will be used to ensure internal mechanical integrity. In addition, annulus pressure tests will be periodically conducted to confirm gauge measurements.

The purpose of external mechanical integrity testing is to confirm the absence of significant leakage outside of the casing [(40 CFR §146.89(a)(2))]. OLCV proposes to conduct temperature logging in the Injector wells on an annual basis to demonstrate external mechanical integrity. In addition, OLCV plans to collect continuous temperature profiles above the Injection Zone in Injector wells, using DTS fiber. Based on comparison of results between DTS temperature profiles and temperature logging, OLCV may recommend to the UIC Program Director to cease temperature logging and utilize DTS data only. Ultrasonic tools such as the UltraSonic Imager Tool (USIT™), or IsoScanner are industry-standard tools that provide information on wellbore integrity. One of these methods will be used to monitor integrity in SLR and WW wells.

9.1 Testing Location and Frequency

Table 15 below provides a summary of the internal and external mechanical integrity monitoring methods and mechanical integrity testing (MIT) plans in the injector and monitoring wells.

To demonstrate internal mechanical integrity of the injector wells, OLCV will perform annular pressure tests during well construction and at least once every five years thereafter, coincident with well maintenance operations in which tubing and packer are pulled. Annular monitoring tests will be performed on SLR and WW wells during construction and annually thereafter. Additional testing will be conducted if the pressure or temperature data collected from gauges or DTS indicates a potential reduction in mechanical integrity.

External mechanical integrity testing on Injector wells will be continuously conducted via DTS fiber and using temperature logging to meet and exceed the requirement of annual testing described in 40 CFR §146.89(c). In addition, at least one type of mechanical integrity log will be conducted during construction of each of the injector wells. Logging will be repeated during well maintenance events to minimize disruption to the injection schedule. If DTS data indicate potential loss of mechanical integrity, this event will trigger acquisition of a mechanical integrity log. SLR and WW wells will also have mechanical integrity testing on an annual basis and logging during construction and once at least every five years thereafter, during subsequent well maintenance. The reporting of mechanical integrity testing will comply with

TAC Title 16 Chapter 5.206(e)(1): “The operator of an anthropogenic CO2 injection well must maintain and comply with the approved monitoring, sampling, and testing plan to verify that the geologic storage facility is operating as permitted and that the injected fluids are confined to the injection zone.”

OLCV engineers will monitor downhole P/T data to look for changes that could indicate leakage inside the annulus or outside of the casing. If anomalous measurements are recorded, OLCV personnel will immediately conduct further investigations to determine if there is evidence of surface leakage and take appropriate corrective action. If no surface leakage is detected, OLCV personnel will continue to evaluate the source of the anomalous data and may choose to conduct an annulus pressure test, wireline conveyed P/T gauge, or other logging tool to investigate the borehole integrity. If anomalous data is not found to be the result of operational changes, such as a rate change, injection operations in the affected well will be ceased until the source of the anomalous data is determined and/or corrective action is applied.

Table 15—Internal and External Mechanical Integrity Monitoring Methods and Frequency in Injector Wells

Internal Mechanical Integrity			
Method	Pre-Injection	Injection	Post-Injection
Annular pressure test	During construction and prior to injection	At least once every five years, during well maintenance; and before plugging	NA
DTS	Prior to injection	Continuously	NA
External Mechanical Integrity			
Method	Pre-Injection	Injection	Post-Injection
Temperature log	Prior to injection	Annually	NA
DTS	Prior to injection	Continuously	NA

SLR wells will also be monitored for mechanical integrity.

Table 16—Internal and External Mechanical Integrity Monitoring Methods in SLR and WW wells

Internal Mechanical Integrity			
Method	Pre-Injection	Injection	Post-Injection
Annular pressure test	Prior to injection	Annually and before plugging	At least once every five years, during workovers; and before plugging
Downhole P/T gauges	Prior to injection	Continuously	Continuously for the first 10 years pending an approved PISC plan, then annually until plugging
External Mechanical Integrity			
Method	Pre-Injection	Injection	Post-Injection
Temperature log or other methods: Cement Bond Log (CBL), Variable Density Log, UltraSonic Imager Tool (USIT™), Isolation Scanner™, Electromagnetic Pipe Examiner, Casing Inspection Log	Prior to injection	At least one method once every five years, during well maintenance and before plugging	At least one method once every five years, during workovers; and before plugging
Downhole P/T gauges	Prior to injection	Continuously	Continuously for the first 10 years pending an approved PISC plan, then annually until plugging

9.2 Description of Methods and Justification

9.2.1 Internal Mechanical Integrity Using Annular Pressure Tests

An annular pressure test is a common method to demonstrate internal mechanical integrity. The test is based on the assumption that pressure applied to fluids in the annular space should be constant unless there are significant changes in temperature or a fluid leak.

An overview of the annular pressure test procedure is as follows:

- Shut in the well to stabilize the pressures in the injectors.
- Connect the testing equipment to the annular valves and test surface lines to 1,500 psi above the testing pressure.
- Ensure there are no surface leaks from the pumping unit to the wellhead valve.
- Bleed any air in the system. If needed, fill the annular space with packer fluid and

corrosion inhibitor (if so, it should require only a minimal amount).

- Record the initial tubing and casing pressure. The well will be tested to 500 psi in the annular space, and the pressure should not decrease more than 5% in 30 minutes.
- Monitor the tubing and casing pressures continuously. Record the final tubing and casing pressure, then bleed the pressure and volume. If the pressure decreases more than 5%, bleed the pressure, test the surface connection, and repeat the test. If there is an indication of mechanical failure, the operator will prepare a plan to repair the well and discuss it with the Program Director.

9.2.2 External Mechanical Integrity Using DTS

OLCV plans to install a fiber optic cable alongside the casing in the Injector wells and secure the cable with clamps. The fiber is connected at the surface to an interrogator that converts the signal to temperature values, and the data are transmitted to the monitoring platform in real time for surveillance purposes. These data can provide high-resolution temperature data that can be used to detect subtle changes in fluid movement in a wellbore. Additional information on DTS technology can be found in the Appendix A of this document.

Based on comparison of DTS data with data obtained via a conventional temperature log, OLCV may recommend to the UIC Program Director that future external mechanical integrity testing be conducted utilizing DTS in lieu of temperature logging.

9.2.3 External Mechanical Integrity Testing Using Logging Tools

OLCV proposes to use an ultrasonic tool such as the Isolation Scanner™, or UltraSonic Imager Tool (USIT™). The tools are readily available technologies on the market and are commonly used to demonstrate external mechanical integrity. These tools may be used to demonstrate mechanical integrity on SLR or WW wells. OLCV may also recommend that these tools be used to demonstrate external mechanical integrity on the Injector wells, following a comparison of results with conventional temperature logging.

In the future, new technologies or tools may be proposed for further discussion with regulators. Additional details on tools can be found in Appendix A of this document.

10.0 Pressure Fall-Off Testing

OLCV will perform a pressure fall-off test prior to injection 40 CFR §146.87(e) and during the injection phase as described below to meet the requirements of 40 CFR §146.90(f).

10.1 Testing Location and Frequency

The table below summarizes the pressure fall-off testing plan for the injector well.

Table 17—Summary of pressure fall-off testing

Method	Pre-Injection	Injection	Post-Injection
Fall-off Testing	Prior to injection	At least once every five years during workovers	N/A

Pressure fall-off testing in the form of Step Rate Test will be conducted upon completion of the injection well to characterize reservoir hydrogeologic properties, aquifer response characteristics, and changes in near-well/reservoir conditions that may affect operational CO₂ injection behavior.

Following the commencement of injection operations, pressure fall-off testing will be conducted at least once every five years during injection and before well plugging. The objective of the periodic pressure fall-off testing is to determine whether any significant changes in the near- wellbore conditions have occurred that may adversely affect the well or reservoir performance.

10.2 Description of Methods and Justification

Pressure fall-off testing is a method of monitoring changes that may impact injectivity or pressure response in the near-wellbore environment. Additionally, pressure fall-off testing can be used to monitor wellbore mechanical integrity. The fall-off test is conducted by ceasing injection for a designed time period, and continuously monitoring the pressure and temperature with downhole gauges. The duration of the test is designed to measure the pressure recovery.

Pressure fall-off testing is a proven technology that is widely used in subsurface well operations. The results of pressure fall-off tests will be interpreted by engineers and geologists who are experienced in analyzing this type of data. Experienced senior advisors will be consulted to add additional technical insight. The interpretation will be used to confirm or update operational parameters and confirm wellbore mechanical integrity.

Pressure gauges used to conduct fall-off tests will be calibrated in accordance with the manufacturers’ recommendations. In lieu of removing the injection tubing to recalibrate the downhole pressure gauges, their accuracy will be demonstrated by comparison with a second pressure gauge with current certified calibration, which will be lowered into the well to the same depth as the permanent downhole gauge. Calibration curves for the downhole gauge, based on annual calibration checks using the second calibrated gauge, can be used for the fall-off test. These calibration curves (showing all historic pressure deviations) will accompany the

fall-off test data.

10.3 Interpretation of fall-off test results

Quantitative analysis of the pressure fall-off test response provides the basis for assessing near- well and larger-scale reservoir behavior. Comparison of diagnostic pressure fall-off plots measured before CO₂ injection and during the operational injection phases can be used to determine whether significant changes in well or storage reservoir conditions have occurred. Diagnostic derivative plot analysis (Bourdet et al., 1989; Spane, 1993; Spane and Wurstner, 1993) of the pressure fall- off recovery response is particularly useful for assessing potential changes in well and reservoir behavior.

Plotting the downhole temperature concurrent with the observed fall-off test pressure is useful to check for anomalous pressure fall-off recovery response. Commercially available pressure gauges typically are self-compensating for environmental temperature effects within the probe sensor (i.e., within the pressure sensor housing). However, if temperature anomalies are not accounted for correctly (e.g., well/reservoir temperatures are responding differently than registered within the probe sensor), erroneous pressure fall-off response results may be derived. Thus, concurrent plotting of downhole temperature and pressure fall-off responses is useful for assessing whether temperature anomalies may be affecting pressure fall-off recovery behavior. In addition, diagnostic pressure fall-off plots should be evaluated relative to the sensitivity of the pressure gauges used to confirm adequate gauge resolution (i.e., excessive instrument noise).

Standard diagnostic log-log and semi-log plots of observed pressure change and/or pressure derivative plots vs. recovery time are commonly used as the primary means for analyzing pressure fall-off tests. In addition to determining specific well performance conditions (e.g., well skin) and aquifer hydraulic property and boundary conditions, the presence of prevailing flow regimes can be identified (e.g., wellbore storage, linear, radial, spherical, double-porosity) based on characteristic diagnostic falloff pressure derivative patterns. A more extensive list of diagnostic derivative plots for various formation and boundary conditions is presented by Horne (1990) and Renard et al. (2009).

Early pressure fall-off recovery response corresponds to flow conditions in and near the wellbore, whereas later fall-off recovery response is reflective of reservoir conditions progressively farther from the injection well location. Significant divergence in pressure fall-off response patterns from previous tests (e.g., accelerated pressure fall-off recovery rates) may be indicative of a change in well and/or reservoir conditions (e.g., reservoir leakage). A more detailed discussion of using diagnostic plot analysis of pressure falloff tests for

discerning possible changes to well and reservoir conditions is presented by the EPA (2002).

11.0 Carbon Dioxide Plume and Pressure Front Tracking

OLCV will monitor the CO₂ plume and pressure front using both direct and indirect methods pursuant to 40 CFR §146.90(g)(1) and (2). A summary of the methods used for CO₂ and pressure front tracking are provided in Table 18 below.

11.1. Monitoring Location and Frequency

Direct tracking methods include:

- Geochemical monitoring of fluids in the Injection Zone and shallow fluids and gasses. Note that a detailed description of geochemical characterization and monitoring is presented in Section 6 of this document.
- Pressure and temperature measurements from the Injection Zone, and the first permeable layer above the confining zone.

Indirect tracking methods include:

- Estimation of CO₂ saturation using Reservoir Saturation Tool (RST) or Pulsed-Neutron logs (PNL) in SLR2 and SLR3 wells.
- Evaluation of the development and migration pattern of the CO₂ plume and pressure front using time-lapse 2D VSP and 2D surface seismic.
- Calibration of the dynamic simulation model for the AoR re-evaluation.

Table 18—Direct and indirect methods of tracking the CO₂ plume and pressure front

Direct Methods				
Objective	Method	Pre-Injection	Injection	Post-Injection
Measure geochemical composition of the Injection Zone	Fluid and dissolved gas sampling in SLR2 and SLR3 wells	During construction and one additional sampling in SLR2	Event-driven*	Event-driven* until plugging
	Fluid and dissolved gas sampling in USDW-level well	Quarterly for at least one year	Quarterly during years 1-3; annually starting in year 4	Annually for first 10 years pending an approved PISC plan
	Fluid sampling in WW wells	Quarterly for approximately one year	Event-driven*	NA
Measure P/T of the Injection Zone	P/T using gauges and/or DTS in SLR2 and SLR3 wells	In SLR2, prior to injection	Continuous	Continuously for the first 10 years pending an approved PISC plan
Indirect Methods				
Objective	Method	Pre-Injection	Injection	Post-Injection
Estimate CO ₂ saturation in the Injection Zone	PNL or RST in INJ wells	Prior to injection	Event-driven*	NA
	PNL or RST in SLR2 and SLR3 wells	In SLR2, prior to injection	Annually	Annually until plugging
	PNL or RST in WW wells	Prior to injection	Once every five-year period	NA
Estimate CO ₂ plume and pressure extent in the Injection Zone	2D VSP in INJ wells	Prior to injection	2D VSP at years 1, 2, 5 and 10	NA
	2D VSP in selected SLR wells	Prior to injection at SLR2	2D VSP in year 5 or 10	Once approximately every five-year period until plugging or plume stabilization
	2D surface seismic	Prior to injection	Year 10	Once approximately every five-year period until plume

				stabilization
	DInSAR with GPS	Prior to injection	Quarterly	Annually for five years or until plume stabilizes
	Computational modeling	Prior to injection	As needed, to be used for AoR re-evaluation	As needed, to be used for AoR re-evaluation

*OLCV will monitor pressure and temperature data obtained from downhole gauges and/or DTS fiber daily, and also routinely evaluate long-term data trends to detect deviations from the reference temperature or pressure gradient. If persistent deviations in temperature or pressure are detected, OLCV will obtain reservoir fluid samples and analyze fluid and dissolved gas chemistry to determine the presence or absence of increased CO₂. Saturation logging may also be conducted to further support or refute the presence of increased CO₂.

11.2 Description of Methods and Justification

The direct and indirect tracking methods described in this document meet and/or exceed the requirements of the Testing and Monitoring plan established in UIC Class VI. The proposed methods are proven technologies and have been used by the Operator to safely conduct subsurface operations for decades. Additional new technologies will be considered in a cost versus benefit analysis and added to the plan if they are deemed to be warranted.

11.2.1 Geochemical Monitoring

Geochemical monitoring will be employed in SLR2, SLR3 and USDW monitoring well. These data will be compared with the pre-injection geochemical and isotopic characterization to constrain whether changes are observed. If changes are measured, then OLCV will constrain whether the compositional changes are likely to be the result of naturally occurring biological processes or another source. Additional details on geochemical monitoring are described in Section 6 of this document.

11.2.2 Pressure and Temperature Monitoring

Pressure and temperature gauges will be deployed on the tubing above and below the injection packer to monitor bottomhole conditions in real time. In SLR2 and SLR3 wells, the gauges and cables will be selected to withstand CO₂ service conditions. These data will be integrated in the SCADA system and surveillance platform. OLCV will routinely evaluate the data and interpret the results. If a change in pressure or temperature is recorded, OLCV will evaluate and attribute the source of the change. Additional details on downhole gauge instrumentation are described in the

QASP document that is part of this application.

The SLR1 well also contains DTS and DAS fiber for monitoring pressure and temperature. However, the fiber was damaged near the top of the Injection Zone. The fiber may provide pressure and temperature data on shallower zones including the Upper Confining Zone, and it may be used for collecting VSP data.

11.2.3 Saturation Detection Tool Method

Reservoir saturation tool (RST) / pulsed neutron logs (PNL) will be run through the tubing to detect changes in CO₂ saturation and identify potential breakthrough of the plume. The pulsed neutron log is considered a proven technique to detect gas saturation in reservoirs. Advances in the technology have improved the accuracy of the tool for tracking movement of CO₂ plumes in the reservoir and evaluating flow conformance. Details of the saturation log / pulsed neutron technique are described in Appendix A to the Testing and Monitoring Plan.

OLCV plans to collect saturation logs in SLR2 and SLR3 wells on a yearly basis. These measurements will provide a record to track potential changes in fluid over time in the Injection Zone. To help calibrate data from the Injection Zone, saturation logs will also be collected in the Injector wells once every five years. The first permeable zone above the confining zone is not expected to encounter any CO₂ from injection. A saturation log may be conducted in the SLR1 and ACZ1 to monitor above the confining zone approximately once every five years.

11.2.4 Repeat Seismic Methods

Baseline seismic acquisition

2D and 3D surface seismic was collected in 2022 for use in site characterization, and as pre-injection baseline of the BRP site. The 3D was acquired in an area of approximately 20 mi² and extends approximately one mile beyond the anticipated CO₂ and pressure plumes. Approximately 10 miles of 2D surface seismic was acquired. The survey was designed with a high density of sources and receivers to image from the near-surface down to basement. Vibroseis was used as the source for the acquisition. The processing sequence included pre-processing, pre-stack depth migration and velocity model building, followed by post-migration processing.

Justification of time-lapse seismic methods

OLCV integrated the results of the 2D and 3D seismic with rock and fluid properties measured in the Shoe Bar 1 (SLR1) and Shoe Bar 1AZ (ACZ1) to screen for detectability of a geophysical response resulting from a change in fluid or pressure in the Injection Zone. Figure 8 shows a forward model based on the Shoe Bar 1AZ that demonstrates the geophysical response resulting from a 20% CO₂ saturation in porous (>8p.u.) zones over a ~500 ft thick carbonate as described in

Figure 8. This screening result demonstrates the subtlety of time-lapse changes to sonic and density logs in the Injection Zone.

The detectability of a change in fluid or pressure is improved by utilizing wellbore seismic methods, therefore OLCV proposes to acquire seismic using a Vertical Seismic Profile (VSP) in wellbores. Modeling conducted by OLCV indicates that 2D VSP is an appropriate seismic method. Because of the low dip on the Injection and Confining Zone units, 3D VSP is not modeled to yield a significant advantage over 2D VSP, and therefore 2D VSP is proposed for this study.

The imaging area of a VSP is limited to ~3500 – 3800 feet away from the wellbore, based on modeling conducted by OLCV and a third-party contractor. To image the full extent of the AoR, OLCV proposes to acquire 2D surface seismic in a radial pattern centered near the surface location of the injector wells. For surface methods, the detectability of a time-lapse response resulting from a change in fluid or pressure improves with higher concentrations of CO₂. Therefore, surface seismic will be used as a monitoring technique in the later part of the Injection Phase and in the PISC.

New and emerging technologies

OLCV will re-evaluate new and improving time-lapse monitoring techniques, such as a Scalable, Automated, Sparse Seismic Array (SASSA), at least every five years and will recommend changes to the monitoring plan if these technologies are interpreted to provide improved monitoring results. Recommendations will be reviewed with the UIC Program Director.

11.2.5 DInSAR and GPS data acquisition

The BRP Project plans to use Differential Interferometric Synthetic-Aperture Radar (DInSAR) and Global Positioning Systems (GPS) data to indirectly monitor the position of the CO₂ pressure plume. DInSAR is a non-intrusive, non-destructive technology that measures, with high accuracy, relative displacement over time. It is highly effective for measuring ground deformation over multiple years. A network of 10 “corner reflectors” will be installed by a third-party contractor to serve as permanent monuments to aid in data processing repeatability. Prior to injection a historical evaluation of past ground movement will be conducted. These data will be licensed from a third- party DInSAR contractor and interpreted by the contractor and by qualified Oxy and OLCV personnel.

To further improve the resolution and accuracy of DInSAR, BRP plans to install a local geodetic network of GPS stations to provide a common space-temporal reference frame for all geodetic and geophysical surveys in the area. For this study area, approximately 10 stations will be placed in a regularly-spaced array. Each station typically consists of a four-inch pipe installed at a depth of

5-11 feet. Stations will be installed by a third-party contractor. Data will be processed by qualified Oxy or OLCV personnel or by third-party contractors.

DInSAR coupled with GPS technology provides sub-millimeter ground surface deformation data that informs the following interpretations:

- Surface impact caused by subsidence or uplift induced by Injection Zone operations.
- Calibration of geomechanical models by providing information on the mechanical properties of the Injection and Confining Zones.
- Monitoring of the stress field depth.
- Identification of potential leakage pathways.

Table 19 below describes the sampling and recording frequency for DInSAR and GPS data. See Figure 7 for the planned locations of corner reflectors.

Table 19—Summary of DInSAR and GPS sampling plans

Objective	Method	Minimum sampling frequency	Minimum recording frequency
Measure surface displacement	DInSAR	Quarterly	Image recording bi-weekly
	GPS	Quarterly	Quarterly

11.2.6 Dynamic simulation modeling

A dynamic simulation model has been constructed and is used to inform the interpretation of the AoR. This model will be evaluated after the commencement on injection operations and calibrated to operational data. The model will be updated, as needed, to meet the requirements of 40 CFR

§146.84(e) that require AoR re-evaluation on a fixed frequency not to exceed five years. The frequency of model updates will be dependent on the amount of deviation from the predicted plume and pressure front.

Dynamic simulation modeling is used to predict changes in the Injection and Confining zones over time. OLCV first constructed a static geocellular model using log, core, and seismic data from the site. Stratigraphic tops were selected on well logs and then mapped throughout the field to form a stratigraphic framework. The framework was divided into geologic zones and assigned rock and fluid properties derived from log and core analysis. The static geomodel forms the basis for the reservoir simulation model.

OLCV constructed a dynamic simulation model that tracks the composition of brine and CO₂ through time. Following the commencement of injection operations, the predictions made on CO₂ and pressure front movement will be calibrated with direct and indirect plume and pressure tracking data. These data will be used to history match the dynamic model and then update forecasts of plume and pressure movement in the future. Significant deviation from forecasts will lead to updates to the AoR delineation. See additional information on delineation of the AoR in the AoR and Corrective Action Plan that is part of this application.

11.2.7 Interpretation and Analysis of Data Collected

The data collected with direct and indirect tracking methods will be evaluated by subsurface geologists and engineers. In addition, OLCV will utilize senior technical advisors to review work products and provide additional technical insight. Data will be routinely reviewed and integrated into and updated subsurface characterization that will be used to inform the AoR and future testing and monitoring plans.

12.0 Induced Seismicity Monitoring

12.1 Description of Methods and Justification

12.1.1 Traffic Light System for Monitoring Induced Seismicity

Based on information provided by the United States Geological Survey (USGS), the BRP Project area does not show high seismic activity that could endanger the containment of the CO₂ in the storage complex. Seismicity history is discussed in more detail in the Area of Review and Corrective Action Plan document of the permit.

Change of in-situ stresses on existing faults caused by human activities (e.g., mining, dam impoundment, geothermal reservoir stimulation, wastewater injection, hydraulic fracturing, and CO₂ sequestration) may induce earthquakes on critically stressed fault segments. To monitor potential induced seismicity due to the injection of CO₂ in the area, it is proposed that the project deploy surface seismometer stations.

While the historical seismicity of the project area indicates no earthquakes in the immediate vicinity, the operator intends to monitor the site with a seismic monitoring system for the duration of the project to ensure the safe operation of both the storage facility and adjacent infrastructure in the area. The seismic monitoring will be conducted with a surface array deployed to ensure detection of events above local magnitude (ML) 1.0, with epicentral locations within 10 miles of the injection well.

If an event is recorded by either the local private array or a public (national or state) array occurs within 10 miles of the injection well, OLCV will implement the response plan subject to detected earthquake magnitude limits defined below to eliminate or reduce the magnitude and/or frequency of seismic events:

- For events above ML 2.0 but below ML 3.5 within 5.6 miles of the injection wells, OLCV will closely monitor seismic activity and may implement a pause to operations or continue operations at a reduced rate, should analysis indicate a causal relationship between injection operations and detected seismicity. The 5.6 mile radius is used because this is the metric used for disposal well applications to the Railroad Commission. “Pursuant to 16 Texas Administrative Code §3.9(3)(B) and §3.46(b)(1)(C), SWD well permit applications must include a review of USGS earthquake records for a circular area of 100 square miles around the proposed SWD well location (a circular area with a radius of 9.08 kilometers, or 5.64 miles).”
- For events with ML 3.5 to ML 4.5 within 5.6 miles of the injection well, OLCV will initiate contact with relevant regulatory and/or government entities. OLCV will begin a technical review within 24 hours of the event to determine if a causal relationship exists. Should a causal relationship be determined, a revised injection plan would be developed to reduce or eliminate operationally related seismicity. Such plans are dependent on the pressures and seismicity observed and may include, but not limited to:
 1. Reducing CO₂ injection pressures until reservoir pressures fall below a critical limit.
 2. Increasing water production rates until reservoir pressures fall below a critical limit
 3. Continuing operations at a reduced rate and/or below a revised maximum operation pressure.
 - o OLCV will obtain approval from the relevant regulatory and/or government entities to implement revised plan.
 - o If the event is not related to the storage facility operation, OLCV will resume normal injection rates.
- For events above ML 4.5 within 5.6 miles of the injection well, OLCV will stop injection as soon as safely practical. OLCV will inform the regulator of seismic activity and inform them that operations have stopped pending a technical analysis. OLCV will initiate an inspection of surface infrastructure for damage from the earthquake. A detailed analysis will be conducted to determine if a causal relationship exists between injection operations and observed seismic activity. Should a causal relationship be determined, a revised injection plan would be developed to reduce or eliminate operationally related

seismicity before resuming injection operations. Such plans are dependent on the pressures and seismicity observed and may include, but not be limited to:

1. Reducing injection pressures until reservoir pressures fall below a critical limit.
2. Increasing water production rates until reservoir pressures fall below a critical limit.
3. Continuing operations at a reduced rate and/or below a revised maximum operation pressure.
 - o OLCV will obtain approval from the relevant regulatory and/or government entities to implement a revised plan.
 - o If the event is not related to the storage facility operation, and with prior approval from the regulators, OLCV will adjust injection and/or production rates to previous rates in steps, while increasing the surveillance.

12.1.2 Induced Seismicity Monitoring Network

Presently, the nearest seismometers to the AoR are part of the MTX and TexNet arrays. The USGS seismometer network in Texas is known as TexNet. The MTX array is a private subscription array. Oxy has been a subscriber to MTX since its inception in 2017. Together, the data from the TexNet and MTX arrays provide accurate seismicity information throughout the Permian Basin.

OLCV plans to install five additional seismometers delivering real-time seismicity alerts within the BRP Project area. To achieve the lowest magnitude of completeness within the AOR, modeling is ongoing to identify optimal locations to site the new seismometers. Installation is expected mid-2024. The data from seismometers installed for the purposes of the BRP Project are not intended to be publicly available.

A seismometer monitoring network will be deployed to determine the locations, magnitudes, and focal mechanisms of any injection-induced seismic events in case they occur. This information will be used to address public concerns and to monitor changes in induced seismicity risks with a goal of reacting to the perceived risk through adjustment of well operations as needed.

A map of proposed new station locations is provided in Figure 10 (and also Figure 7). Existing locations are provided as attachment in the GSDT. These station locations were used for modeling the expected sensitivity of the array at the project site. Locations are subject to change in order to optimize the station locations around surface infrastructure and access limitation and changes to the pressure plume modeled so as to provide optimum monitoring of the site.

The design and installation of the station array is performed by specialized contractors and include the following activities:

- Project management support to design the seismometer array, model the network

performance, coordinate permitting and equipment installation, conduct testing and maintenance, and ensure optimum execution of the Project.

- Field operations to deploy seismic station instrumentation, run power and communication systems, monitor data quality, and do commissioning.
- Data acquisition, system configuration, and process setup.
- Continuous support and monitoring for data verification and QA/QC.
- Continuous near-real-time reporting, including analyst reviews and alert notifications, for events at or above predetermined magnitude thresholds over the seismic area.

12.1.3 Seismicity Monitoring Equipment

The equipment proposed for seismicity monitoring includes: broadband sensors, a data logger, a solar power system and backup battery, communication system, cabling, and mounting equipment (Figure 11).

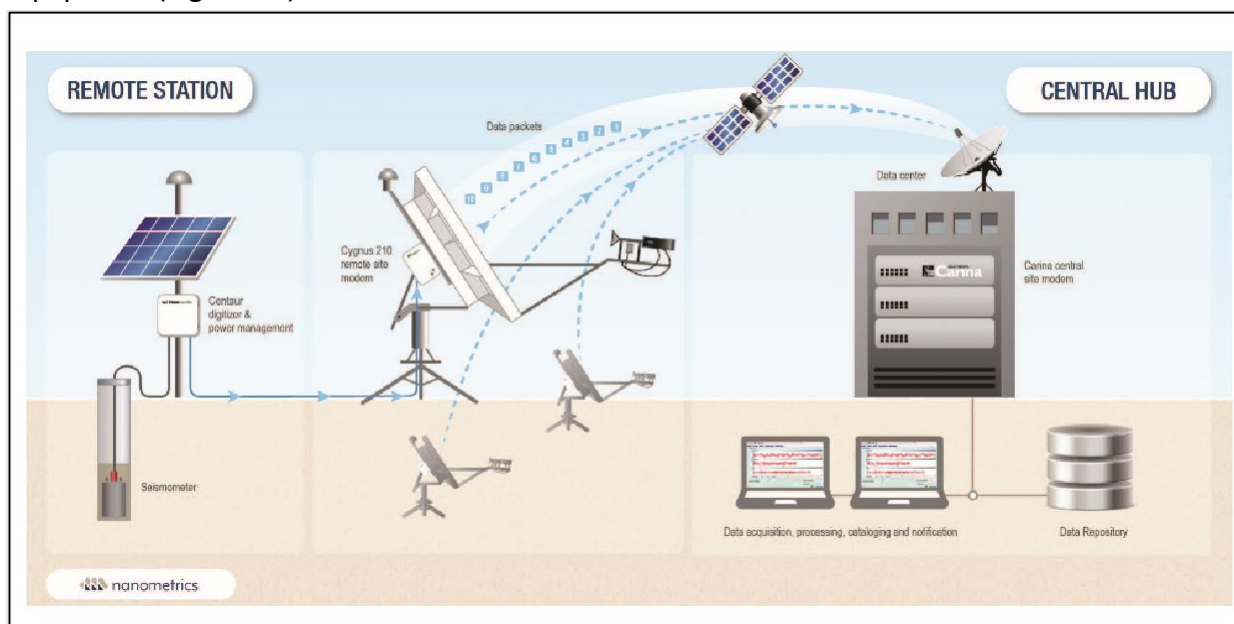

Figure 11—Example of a setup for data acquisition, transfer, storage, and analysis.

13.0 Reporting

The results of all testing and monitoring are to be described in a semi-annual report that will be submitted to the EPA.

ATTACHMENT 7: WELL PLUGGING PLAN

Facility name: Brown Pelican CO2 Sequestration Project
BRP CCS1, CCS2, and CCS3 wells

Well location: Penwell, TX

BRP CCS1	31.76479314	-102.7289311
BRP CCS2	31.76993805	-102.7332448
BRP CCS3	31.76031163	-102.7101566

Plugging procedures for CO₂ Injection wells are presented in this document. Plugging plans for monitoring and water withdrawal wells are presented in Appendix A of this document.

1.0 CO₂ Injection Wells

1.1 Planned Tests or Measures to Determine Bottomhole Reservoir Pressure

1. After injection has ceased, the well will be flushed with a kill fluid. A minimum of three tubing volumes will be injected without exceeding the fracture pressure. All kill fluids that will be pumped will be 10 ppg NaCl brine.
2. Bottomhole pressure measurements will be taken using the installed downhole gauges. In case the gauges are not functioning properly, the operator will run a pressure gauge during the P&A process of the well.
3. A Temperature log will be run, and the well will be pressure tested to ensure integrity both inside and outside the casing before plugging. Production Logging Tool (PLT), tracers, and noise or active pulsed neutron logs could be run in substitution.
4. If a loss of mechanical integrity is discovered, the well will be repaired before proceeding further with the plugging operations.
5. All casing in this well will have been cemented to the surface at the time of construction and will not be retrievable at abandonment.
6. After injection is terminated permanently, the injection tubing and packer will be removed.
7. The balanced-plug placement method will be used to plug the well. A cement retainer will be used to isolate the perforated section and prevent flowback of formation fluids that could contaminate the plug.
8. All of the casing strings will be cut off at least 5 ft below the surface and plow line.
9. A blanking plate with the required permit information will be welded on top of the cutoff

casing.

Any necessary revisions to the well plugging plan to address any new information collected during logging, testing, and completion of the well will be made after these activities have been completed. The final plugging plan will be submitted to the Underground Injection Control (UIC) Program Director.

1.2 Planned Mechanical Integrity Test(s)

OLCV will conduct a temperature log and potentially additional logs listed in Table 1 and a pressure test to verify mechanical integrity before plugging the injection well, as required by 40 CFR §146.92(a).

Table 1—Planned and Possible Mechanical Integrity Tests

Test Description	Location
Temperature log (External MIT)	Injection wells and monitoring wells
Pulsed neutron log (External MIT)	Injection wells and monitoring wells
Noise log (External MIT)	Injection wells and monitoring wells
Annular Pressure Test (Internal)	Injection wells and monitoring wells

The following tools are able to detect fluid movements behind the long string casing. Tools will be run on wireline. Quality assurance for the logs will be provided by the vendor at time of selection.

Temperature logs are used to locate gas entries, detect casing leaks, and evaluate fluid movement behind casing. They are also used to detect lost-circulation zones and cement placement. Temperature logs are used as a basic diagnostic tool and are usually paired with other tools like acoustics or multi arms calipers if more in depth analysis is required.

Temperature instruments used today are based on elements with resistances that vary with

temperature. The variable resistance element is connected with bridge circuitry or constant current circuit, so that a voltage response proportional to temperature is obtained. The voltage signal from temperature device is then usually converted to a frequency signal transmitted to the surface, where it is converted back to a voltage signal and recorded. The absolute accuracy of temperature logging instruments is not high (in the order of $\pm 5^{\circ}\text{F}$), but the resolution is good (0.05°F) or better, although this accuracy can be compromised by present day digitalization of the signal on the surface. The temperature instrument usually can be included in the string with other tools, such as radioactive tracer tools or spinner flowmeters. Temperature logs are run continuously, typically at cable speeds of 20 to 30 ft/min.

The following tools could be run in substitution of temperature log. They follow the same principle of detection of anomalies outside the injection zone.

Pulse neutron log (PNL) provides formation evaluation and reservoir monitoring in cased holes. PNL is deployed as a wireline logging tool with an electronic pulsed neutron source and one or more detectors that typically measure neutrons or gamma rays. High-speed digital signal electronics process the gamma ray response and its time of arrival relative to the start of the neutron pulse. Spectral analysis algorithms translate the gamma ray energy and time relationship into concentrations of elements. Each logging company has its own proprietary designs and improvements on the tool.

Schlumberger's Pulsar Multifunction Spectroscopy Service (PNX) pairs multiple detectors with a high output pulsed neutron generator in a slim tool with an outer diameter (o.d.) of 1.72 in. for through-tubing access in cased hole environments. The housing is corrosion-resistant, allowing deployment in wellbore environments such as CO_2 . The tool's integration of the high neutron output and fast detection of gamma rays with proprietary pulse processing electronics, allows to differentiate and quantify gas-filled porosity from liquid-filled and tight zones. The tool can accurately determine saturation in any formation water salinity across a wide range of well conditions, mineralogy, lithology, and fluid contents profile at any inclination. Detection limits for CO_2 saturation for the PNX tool vary with the logging speed as well as the formation porosity. Detailed measurement and mechanical specifications for the PNX tool are provided in the QASP document. The wireline operator will provide QA/QC procedures and tool calibration for their equipment.

Halliburton's RMT-D reservoir monitor tool: The Halliburton Reservoir Monitor Tool 3-Detector™ (RMT-3D™) pulsed-neutron tool solves for water, oil, and gas saturations within reservoirs using three independent measurements (Sigma, C/O, and SATG). This provides the ability to uniquely solve simple or complex saturation profiles in reservoirs, while eliminating phase-saturation

interdependency. The RMT-#D provides gas phase analysis to identify natural gases, nitrogen, CO₂, steam, and air. The tool has 2.125 in diameter OD that allows it to be run through tubing.

Pass/Fail Criteria

Well Plugging is considered pass when it meets the objective of minimizing the chance of leak of fluid to USDW.

Temperature Survey

The temperature log is one of the approved logs for detecting fluid movement outside pipe. A final differential temperature survey will be run during plugging operations and will provide a final temperature curve.

The temperature will be logged down from the surface to total depth in the well. Recommended line speed for the logging operations is 20 to 30 ft/min. In general, the procedure for wireline operations will be as follows:

1. Attach a temperature probe and casing collar locator (CCL) to the wireline.
2. Begin the temperature survey. The tools will be lowered into well at 20 to 30 feet/minute, recording temperature in wellbore. The temperature survey will be run to the deepest attainable depth in the wellbore.
3. Following completion of the survey, the wireline tools will be retrieved from the wellbore.
4. A successful temperature log will "PASS" if there are no observed, unexplained anomalies outside of the permitted injection zone.
5. If temperature anomalies are observed outside of the permitted zone, additional logging may be conducted to determine whether a loss of mechanical integrity or containment has occurred. Depending on the nature of the suspected movement, radioactive tracer, noise, oxygen activation, or other logs approved by the UIC Program Director may be required to further define the nature of the fluid movement or to diagnose a potential leak.

Pressure Test

After setting the initial plug across the well completion interval / perforation, an annular pressure test (APT) will be conducted to verify internal mechanical integrity. The APT is a short-term pressure test (30 minutes) where the well is shut in and the fluid in the annulus is pressurized to a predetermined pressure and is monitored for leak off. BRP will use a test pressure of 500 psi for the Mechanical Integrity Test. BRP will use a 5% decrease in pressure (test pressure x .05) from the stabilized test pressure during the duration of the test to determine if test is successful. If the

annulus pressure decreases by $\geq 5\%$, the well will have failed the APT. If a well fails an APT, the test will be repeated. If the APT is again failed, the downhole equipment will be removed from the well and the source of the failure will be investigated. In general, the test procedure will be as follows:

1. Connect a high-resolution pressure transducer to the annulus casing valve and increase the annulus pressure to 500 psi and hold this pressure for 30 minutes.
2. At the conclusion of the 30-minute test the annulus pressure will be bled off to 0 psi and the pressure recording equipment will be removed from the casing valve.

Note: If a failure in the long string casing is identified, the operator will prepare a plan to repair the well before plugging and abandonment

1.3 Information on Plugs

OLCV will use the materials and methods noted in Table 2, Table 3, and Table 4 to plug the Injection wells. The volume and depth of the plug or plugs will depend on the final geology and downhole conditions of the well as assessed during construction.

The cement(s) formulated for plugging will be compatible with CO₂. Discussion about CO₂ resistant cement selection and additive is located in the Construction Plan – Appendix B. The cement formulation and required certification documents will be submitted to the agency along with the well plugging plan. OLCV will report the wet density and will retain duplicate samples of the cement used for each plug. In plugging procedures in Section 3.0, curing time for CO₂ resistant cement is assumed to be 4 hours. The curing time for the CO₂ resistant plugs will be determined at time of operation via laboratory testing in compliance with API 10B2 (Testing of Oilwell Cements). OLCV utilizes industry recognized thresholds of 50 psi compressive strength to pressure test and 500 psi compressive strength for physically tagging. 500 psi (or greater) compressive strength will be achieved for abandonment slurries and will be reached in < 48 hours after placement. All plug mud will be 9.5-10 ppg NaCl brine with lime added at 1.0 ppb (pound per barrel) to raise the PH to >10.5 to combat corrosion, H₂S and CO₂ contamination. Xanthan gel will be added to the mud so that the viscosity is > 50 sec/qt.

Table 2—Information on Cement Plugs for BRP CCS1

Plug No.	Placement Method	Type Slurry	ID (in.)	MD Depths (ft)	Density (ppg)	Sacks	bbl
1	Squeeze plug	CO2-resistant cement	4.892	4,624 to 5,667	14.8	246	58
2	Balance plug	CO2-resistant cement	4.892	4,524 to 4,624	14.8	12	3
3	Balance plug	CO2-resistant cement	4.892	4,000 to 4,200	14.8	24	6
4	Balance plug	CO2-resistant cement	4.892	3,750 to 3,950	14.8	24	6
5	Balance plug	CO2-resistant cement	4.892	2,700 to 2,800	14.8	12	3
6	Balance plug	CO2-resistant cement	4.892	1,750 to 1,850	14.8	12	3
7	Balance plug	CO2-resistant cement	4.892	791 to 891	14.8	12	3
8	Balance plug	CO2-resistant cement	4.892	0 to 475	14.8	56	13

Notes:

- All plug depths will be adjusted after the well is drilled and completed.
- The plugging procedure will be updated as required by EPA and Texas regulators.
- Formation tops will be adjusted after running openhole electric logs.

Table 3—Information on Cement Plugs for BRP CCS2

Plug No.	Placement Method	Type Slurry	ID (in.)	MD Depths (ft)	Density (ppg)	Sacks	bbl
1	Squeeze plug	CO2-resistant cement	4.892	4,450 to 5,768	14.8	326	77
2	Balance plug	CO2-resistant cement	4.892	4,350 to 4,450	14.8	12	3
3	Balance plug	CO2-resistant cement	4.892	4,000 to 4,200	14.8	24	6
4	Balance plug	CO2-resistant cement	4.892	3,750 to 3,950	14.8	24	6
5	Balance plug	CO2-resistant cement	4.892	2,700 to 2,800	14.8	12	3
6	Balance plug	CO2-resistant cement	4.892	1,750 to 1,850	14.8	12	3
7	Balance plug	CO2-resistant cement	4.892	792 to 892	14.8	12	3
8	Balance plug	CO2-resistant cement	4.892	0 to 475	14.8	56	13

Notes:

- All plug depths will be adjusted after the well is drilled and completed.
- The plugging procedure will be updated as required by EPA and Texas regulators.
- Formation tops will be adjusted after running open hole electric logs.

Table 4—Information on Cement Plugs for BRP CCS3

Plug No.	Placement Method	Type Slurry	ID (in.)	MD Depths (ft)	Density (ppg)	Sacks	bbl
1	Squeeze plug	CO ₂ -resistant cement	4.892	4,900 to 6,006	14.8	268	63
2	Balance plug	CO ₂ -resistant cement	4.892	4,800 to 4,900	14.8	12	3
3	Balance plug	CO ₂ -resistant cement	4.892	4,182 to 4,382	14.8	24	6
4	Balance plug	CO ₂ -resistant cement	4.892	3,700 to 3,900	14.8	24	6
5	Balance plug	CO ₂ -resistant cement	4.892	2,737 to 2,837	14.8	12	3
6	Balance plug	CO ₂ -resistant cement	4.892	1,750 to 1,850	14.8	12	3
7	Balance plug	CO ₂ -resistant cement	4.892	767 to 867	14.8	12	3
8	Balance plug	CO ₂ -resistant cement	4.892	0 to 475	14.8	56	13

Notes:

- All plug depths will be adjusted after the well is drilled and completed.
- The plugging procedure will be updated as required by EPA and Texas regulators.
- Formation tops will be adjusted after running open hole electric logs.

1.4 Plugging Schematics

The proposed plugging schematic for BRP CCS1 is shown in Figure 1, the proposed plugging schematic for BRP CCS2 is shown in Figure 2 and the plugging schematic for BRP CCS3 is shown in Figure 3.

BRP CCS1 - Injector Well (Slant well)

Latitude : 31.76479314/ Longitude : -102.7289311
 ~GL: 2950 ft, ~KB: 20 ft

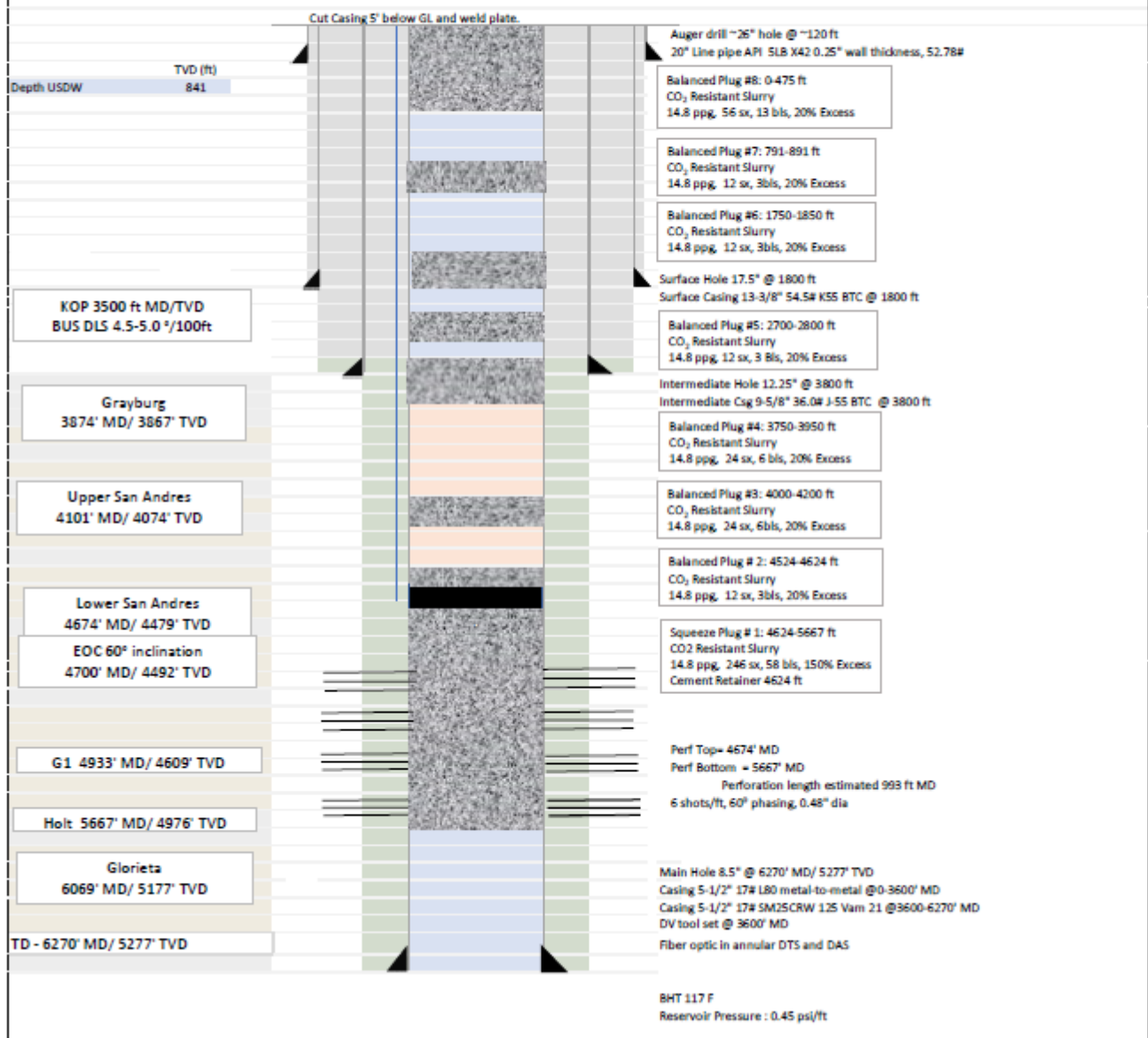

Figure 1—BRP CCS1 well plugging schematic

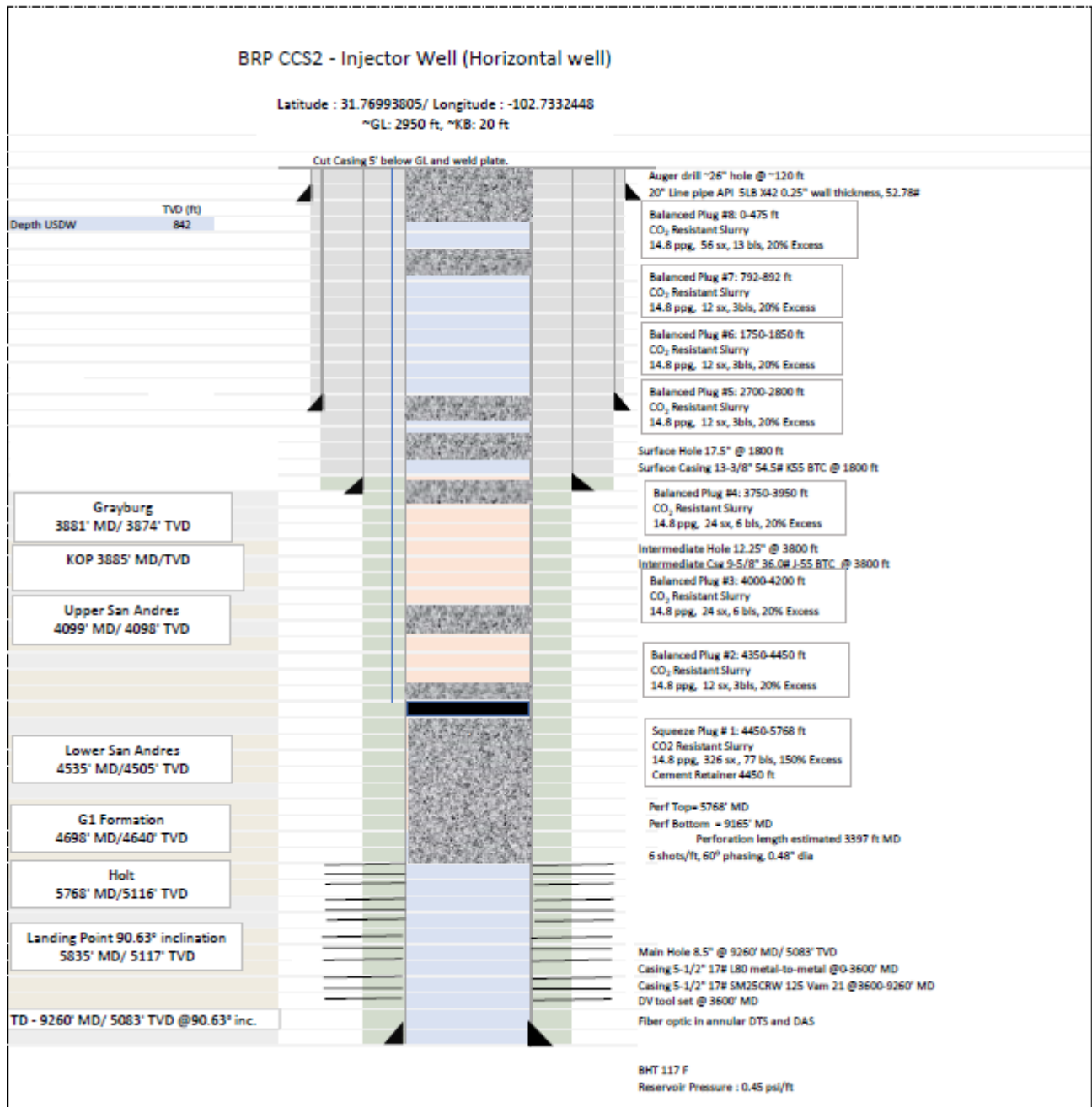

Figure 2—BRP CCS2 well plugging schematic

BRP CCS3 - Injector Well (Slant well)

Latitude : 31.76031163/ Longitude : -102.7101566
 ~GL: 2950 ft, ~KB: 20 ft

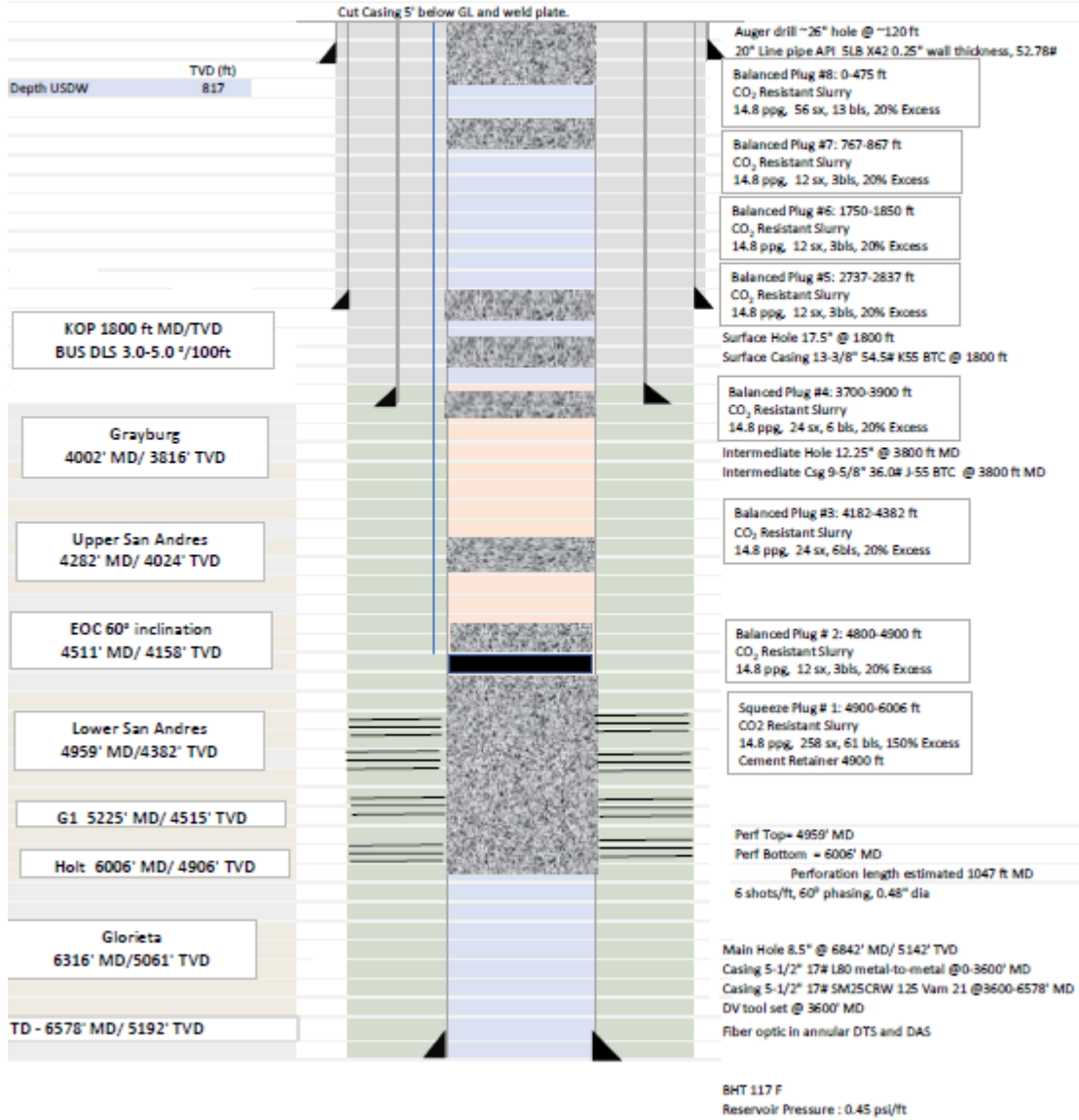

Figure 3—BRP CCS3 well plugging schematic

ATTACHMENT 8: POST-INJECTION SITE CARE AND SITE CLOSURE PLAN

Facility name: Brown Pelican CO2 Sequestration Project
BRP CCS1, CCS2, and CCS3 wells

Well location: Penwell, TX

BRP CCS1	31.76479314	-102.7289311
BRP CCS2	31.76993805	-102.7332448
BRP CCS3	31.76031163	-102.7101566

1.0 Plan Overview

This Post-Injection Site Care and Site Closure (PISC) plan describes the activities that Oxy Low Carbon Ventures, LLC (OLCV) will perform on the Brown Pelican CO2 Sequestration Project (BRP Project or Project) to meet the requirements of 40 CFR §146.93. OLCV will monitor groundwater quality and track the position of the CO2 plume and pressure front for 50 years or for the duration of an alternative timeframe approved by the UIC Program Director pursuant to the requirements of 40 CFR §146.93(c) unless OLCV makes a demonstration under 40 CFR §146.93(b)(2) that OLCV has substantial evidence that the geologic sequestration project no longer poses a risk of endangerment to Underground Sources of Drinking Water (USDWs). Pursuant to 40 CFR §146.93(b)(3), OLCV will continue post-injection site care until the UIC Program Director approves a demonstration that no additional monitoring is needed to ensure non-endangerment of USDWs. Following approval for site closure, OLCV will plug all remaining monitoring wells and submit a site closure report and associated documentation.

3.0 Predicted Position of the CO2 Plume and Associated Pressure Front at Site Closure [40 CFR §146.93(a)(2)(ii)]

The reservoir simulation indicates that after injection ceases, the predicted CO2 plume remains within the Lower San Andres Formation and the area does not expand over time. The colored area in Figure 5 shows the CO2 plume extent in Year 62, as defined by the global mole fraction of CO2. Figure 6 to 8 show a N-S cross section with the CO2 global mole fraction at the end of the injection period at Year 12 and the Year 62 for wells BRP CCS1, CCS2, and CCS3, respectively. There is some minor vertical migration of CO2 to upper portions of the Injection Zone due to buoyancy forces. The AoR is defined by the plume shape and size in Year 12 (end of injection period) because this is the time with the largest differential pressure and CO2 plume. Also, as previously shown in

Figure 3, all pressures are predicted to have been reduced to levels below the level of endangerment to USDWs by Year 62. Therefore, Year 62 (50 years post-injection) is predicted to be the site closure date.

The map in Figure 5 is based on the final AoR delineation modeling results submitted pursuant to 40 CFR §146.84.

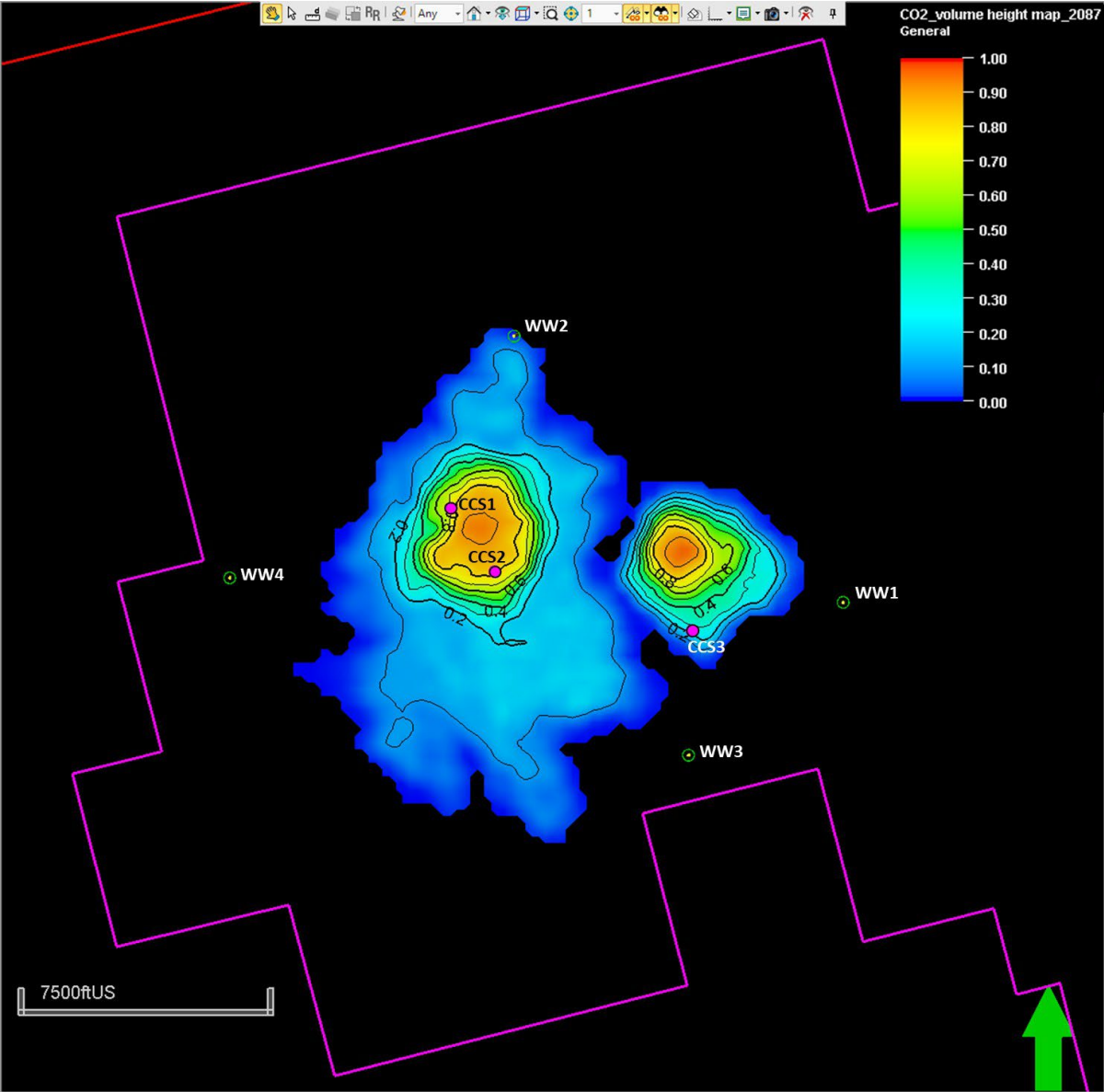

Figure 5--Areal extent of the CO2 plume at site closure in Year 62 since start of CO2 injection (2087), defined by the vertical integration of saturation of CO2 injected.

Figure 9 shows the CO₂ plume size, injected mass, and storage capacity as a function of time, with Year 0 being the initiation of injection. The simulation model predicts that the CO₂ plume (defined as the area containing 99% of the total volume of injected CO₂) increases rapidly during injection. The maximum CO₂ plume area is 4.8 mi² at the end of the injection period with a storage capacity of 1.77 MMT/mi². The plume shrinks after the injection stops from Year 12 to Year 50 and stabilizes in the following years. The shrink behavior of the plume after is due to the buoyancy of the mobile supercritical CO₂ phase which moves in upward direction, and continued dissolution in aqueous phase, decreasing its concentration in the plume edges. Thus, the storage capacity increase until a maximum of 1.95 MMT/mi². Figure 10 depicts areal plume movement based on CO₂ global mole fraction with a 0.1% cutoff. The plume slightly moves from west to east direction, close to Shoe Bar 1 well, due to the model geological features combined with compressibility effect (lower pressure in that region from WW1 water withdraw) allowing small plume migration in the strata. The change in plume size is negligible 50 years after injection, which is the proposed site closure time.

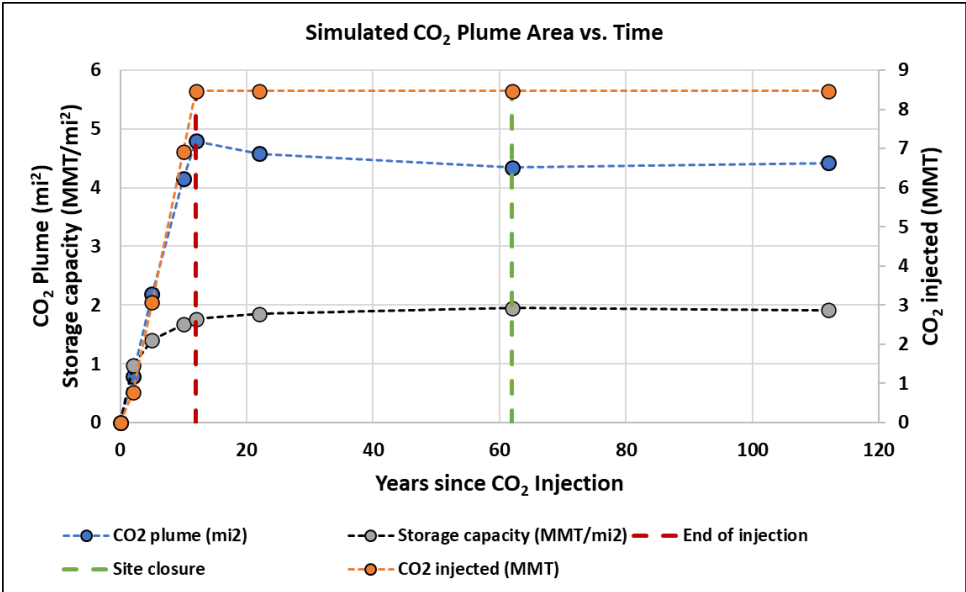

Figure 9--Simulated CO₂ plume area, injected mass, and storage capacity over time. The red and green dashed line denotes the time of end of injection and site closure, respectively.

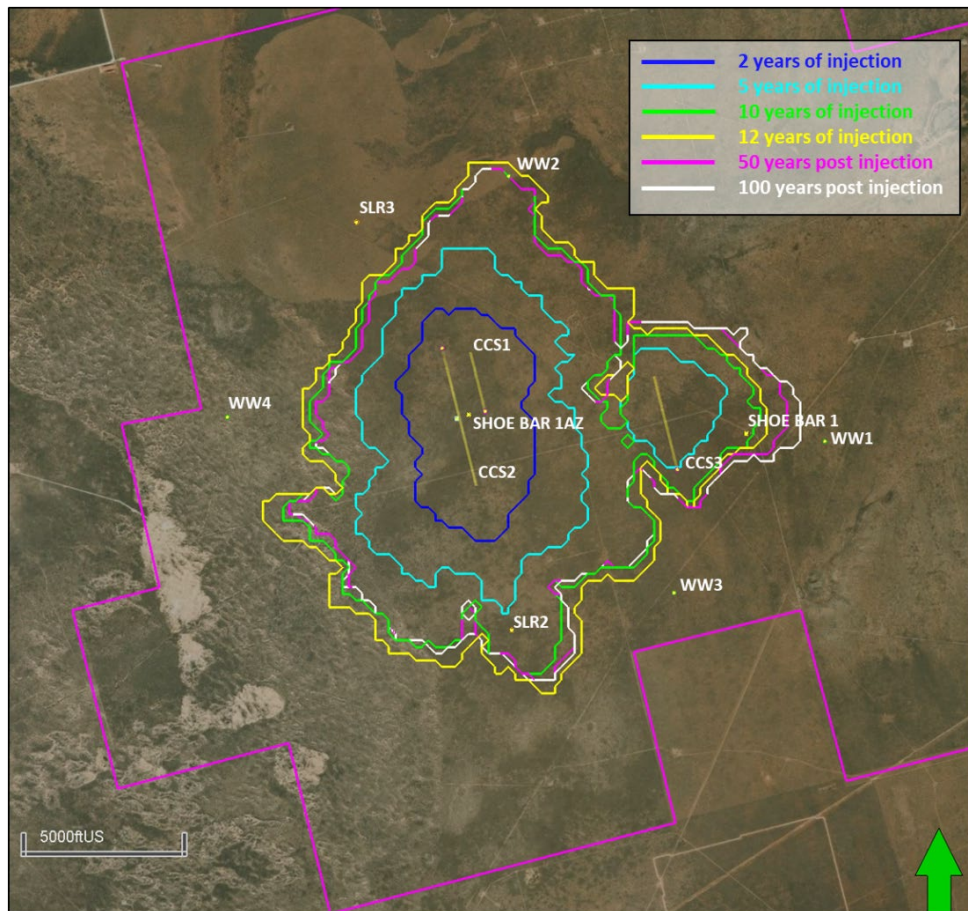

Figure 10--Simulated areal extent of the CO₂ plume from injection start-up to shut-in, then to 100 years after shut-in. Colored outlines represent the migration of the 1% CO₂ saturation front through time.

4.0 Post-Injection Monitoring Plan [40 CFR §146.93(b)(1)]

As described in the following sections, groundwater quality monitoring and plume and pressure-front tracking during the post-injection phase will meet the requirements of 40 CFR §146.93(b)(1). The results of all post-injection phase testing and monitoring will be submitted annually, within 60 days of the anniversary of the date that injection ceases, as described below under Section 5.3 Schedule for Submitting Post-Injection Monitoring Results [40 CFR §146.93(a)(2)(iv)]. Please refer to the Testing and Monitor Plan and Quality Assurance and Surveillance Plan (QASP) document included as part of this application for additional details on testing and monitoring activities during the Post-Injection phase.

A summary of key components of the PISC plan is as follows:

- After the injection ceases, the Injector wells will be plugged and abandoned according to the procedure proposed in the Plugging Plan document of this permit application.
- Pending an approved PISC Plan, for the first 10 years after the cessation of injection, direct measurements of pressure and temperature in the Injection Zone will be obtained in Single Layer Reservoir (SLR) monitoring wells that have not yet been plugged. Fluid samples will be collected if pressure or temperature indicate a change in fluid encountered by the wellbore. If pressure and temperature data are consistent with lack of continued CO₂ migration, pressure and temperature monitoring in the Injection Zone will be continued annually after 10 years until plugging.
- Pending an approved PISC Plan, for the first 10 years following the cessation of injection operations, OLCV will annually collect and analyze the geochemistry of fluids and dissolved gasses from the lowermost USDW in the USDW1 well. These data will confirm the integrity of the Upper Confining Zone. Measurements will be event-driven thereafter. If geochemistry data of fluids and dissolved gasses in the lowermost USDW are consistent with the absence of introduced Injection Zone brine or CO₂ injectate into the USDW, this monitoring method will be discontinued after 10 years.
- If pressure or temperature data in the SLR wells indicates a change in the Injection Zone that could indicate migration of CO₂ plume out of the storage complex, soil gas analysis will be conducted. If changes in soil gas are detected, an attribution study will be performed.
- Annual saturation logging will be conducted in SLR2 and SLR3 wells until plugging and saturation logging will be conducted once every five-year period in ACZ1 and SLR1 if triggered by other data.
- Time-lapse VSP data will be collected in selected SLR wells that have DAS fiber once every five-year period until plugging.
- 2D time-lapse surface seismic will be collected once every five-year period until plume stabilization.
- DInSar and GPS data will be analyzed annually for the first five years post injection.

5.1 Monitoring Above the Upper Confining Zone

Table 3 presents the monitoring methods, locations, and frequencies for monitoring above the Upper Confining Zone.

Table 3—Post-Injection Monitoring Techniques in/above the Confining Zone

Location	Objective	Method	Monitoring Post-Injection
Lowermost USDW / first permeable zone above the confining zone monitoring	Geochemical and isotopic monitoring to detect deviations from expected fluid chemistry	Fluid and dissolved gas sampling	Event-driven*, until plugging
Vadose Zone, Near surface	Isotopic analysis and chemical evaluation to detect changes from expected vadose zone chemistry	Isotopic analysis and chemical evaluation at a minimum of 15 locations	Event-driven*, triggered by P/T data in SLR or ACZ1 wells and fluids sample results
ACZ1 and/or SLR1	Confirming integrity of the Upper Confining Zone	Saturation logging (RST/PNL)	Event-driven*, until plugging
		DTS (SLR1 only)	Continuously for the first 10 years, pending an approved PISC plan

*OLCV will monitor pressure and temperature data obtained from downhole gauges and/or DTS fiber daily, and also routinely evaluate long-term data trends to detect deviations from the reference temperature or pressure gradient. If persistent deviations in temperature or pressure are detected, OLCV will obtain reservoir fluid samples and analyze fluid and dissolved gas chemistry to determine the presence or absence of increased CO₂. In addition, fluid and dissolved gas chemistry data from the lowermost USDW and soil gas chemistry from shallow soils will be monitored for trends to detect deviations from reference chemistry. If persistent and/or abrupt anomalies in chemistry are detected additional fluid or soil gas samples will be obtained to confirm the presence or absence of increased CO₂. Saturation logging may also be conducted to further support or refute the presence of increased CO₂.

5.2 Carbon Dioxide Plume and Pressure Front Tracking [40 CFR §146.93(a)(2)(iii)]

OLCV will employ direct and indirect methods to track the extent of the CO₂ plume and the presence or absence of elevated pressure. Table 4 presents the direct and indirect methods that OLCV will use to monitor the CO₂ plume, including the activities, locations, and frequencies. Fluid sampling, sampling handling and custody, quality control, and quality assurance will be performed as described in the QASP.

Table 4—Post-Injection Monitoring Techniques Plume and Pressure Front Tracking

Location	Objective	Method	Monitoring Post-Injection
SLR2 and SLR3, Injection Zone monitor wells	Fluid and dissolved gas chemistry	Fluid and dissolved gas sampling via wireline	Event-driven* until plugging
	Direct monitoring of pressure and temperature to ensure seal integrity	P/T gauges or DTS	Continuously for the first 10 years pending an approved PISC plan, then annually until plugging
	Indirect monitoring of CO2 concentration	PNL or RST	Annually until plugging
	Plume and pressure extent over time	2D VSP	Once every five-year period until plugging or plume stabilization
	Internal and external mechanical integrity	Pressure and temperature gauges; external MIT	MIT log once every five-year period and before plugging
	Surface leak detection	Visual inspection at wellhead, LDAR/OGI cameras, surface sensors	Continuous surface monitoring and quarterly visual inspection until site closure
ACZ1 and SLR1, Confining Zone monitoring wells	Direct monitoring of pressure and temperature to ensure Upper Confining Zone integrity	DTS (SLR1 only)	Continuously for the first 10 years or until plugging, pending an approved PISC Plan
	Internal and external mechanical integrity	Pressure and temperature gauges; external MIT	MIT log once every five-year period and before plugging
	Indirect monitoring of CO2 presence above the Injection Zone	PNL or RST	Event-driven* until plugging
	Surface leak detection	Visual inspection at wellhead, LDAR/OGI cameras, surface sensors	Continuous surface monitoring and quarterly visual inspection until site closure
Lowermost USDW monitor well	Geochemical and isotopic monitoring to detect deviations from expected fluid chemistry	Fluid and dissolved gas sampling	Annually for first 10 years post injection pending an approved PISC plan; event-driven*, triggered by P/T data in SLR wells or soil gas chemistry
Vadose Zone, Near surface	Isotopic analysis and chemical evaluation to detect changes from expected vadose zone chemistry	Isotopic analysis and chemical evaluation at a minimum of 15 locations	Event-driven*, triggered by P/T data in SLR wells or fluid sample results

2D VSP in selected SLR wells and 2D surface seismic	Estimate CO2 plume and pressure extent	2D VSP and 2D surface seismic	Once approximately every five-year period until plugging or plume stabilization
DInSAR with GPS	Estimate CO2 plume and pressure extent	DInSAR with GPS	Annually for five years or until plume stabilizes
Surface seismicity	Presence or absence of seismicity	Seismometers	Continuous monitoring and recording until site closure

*OLCV will monitor pressure and temperature data obtained from downhole gauges and/or DTS fiber daily, and also routinely evaluate long-term data trends to detect deviations from the reference temperature or pressure gradient. If persistent deviations in temperature or pressure are detected, OLCV will obtain reservoir fluid samples and analyze fluid and dissolved gas chemistry to determine the presence or absence of increased CO₂. In addition, fluid and dissolved gas chemistry data from the lowermost USDW and soil gas chemistry from shallow soils will be monitored for trends to detect deviations from reference chemistry. If persistent and/or abrupt anomalies in chemistry are detected additional fluid or soil gas samples will be obtained to confirm the presence or absence of increased CO₂. Saturation logging may also be conducted to further support or refute the presence of increased CO₂.

5.3 Schedule for Submitting Post-Injection Monitoring Results [40 CFR §146.93(a)(2)(iv)]

OLCV will re-evaluate the AoR every five years during the post-injection phases. In addition, monitoring and operational data will be reviewed periodically by OLCV during the injection and post-injection phases. Monitoring reports will be prepared and submitted to the EPA Region 6 UIC Branch office twice per year. These reports will summarize methods and results of groundwater quality monitoring, CO₂ Injection Zone pressure tracking, and indirect geophysical monitoring for CO₂ plume tracking.

The PISC and Site Closure Plan will be reviewed every five years during the PISC period. Results of the plan review will be included in the PISC monitoring reports. The operational and monitoring results will be reviewed for adequacy in relation to the objectives of the PISC. The monitoring locations, methods, and schedule will be analyzed in relation to the size of the CO₂ Injection Zone, pressure front, and protection of USDWs. In case of changes to the PISC plan, a modified plan will be submitted to the EPA Region 6 UIC Branch Office within 30 days of such changes.

5.0 Non-Endangerment Demonstration Criteria

Prior to approval of the end of the post-injection phase, OLCV will submit a demonstration of non- endangerment of USDWs to the UIC Program Director, per 40 CFR §146.93(b)(2) and (3). This demonstration of USDW non-endangerment will be based on the evaluation of the site monitoring data used in conjunction with the project's computational model. The demonstration will include all relevant monitoring data and interpretations upon which the non-endangerment demonstration is based, model documentation and all supporting data, and any other information necessary for the UIC Program Director to review the analysis. The demonstration will include the following sections:

5.1 Introduction and Overview

A summary of relevant background information will be provided, including the operational history of the injection project, the date of the non-endangerment demonstration relative to the post- injection period outlined in this PISC and Site Closure Plan, and a general overview of how monitoring and modeling results will be used together to support a demonstration of USDW non- endangerment.

5.2 Summary of Existing Monitoring Data

A summary of all previous monitoring data collected at the site, pursuant to the Testing and Monitoring Plan document and this PISC and Site Closure Plan, including data collected during the injection and post-injection phases of the project, will be submitted to help demonstrate non- endangerment. Data submittals will be in a format acceptable to the UIC Program Director, and will include a narrative explanation of monitoring activities, including the dates of all monitoring events, changes to the monitoring program over time, and an explanation of all monitoring infrastructure that has existed at the site. Data will be compared with baseline data collected during site characterization.

5.3 Summary of Computational Modeling History

The computational modeling results used for the AoR delineation will be compared to monitoring data collected during the operational and PISC periods. Monitoring data will also be compared with baseline data collected during the site characterization required under 40 CFR §146.82(a)(6) and §146.87(d)(3). The data will be used to update the computational model and monitor the site and will include both direct and indirect geophysical methods. Direct methods include measurements of pressure, temperature, fluid and dissolved gas

chemistry. Indirect methods include Vertical Seismic Profile (VSP) and 2D seismic, Differential Interferometric Synthetic- Aperture Radar (DInSAR), and saturation logging using Pulsed Neutron (PNL).

Data generated during the PISC period will be used to show that the computational model accurately represents the storage site and can be used as a proxy to determine the plume's properties and size. OLCV will demonstrate this degree of accuracy by comparing the monitoring data obtained during the PISC period with the model's predicted properties (i.e., plume location, rate of movement, and pressure decay). Statistical methods will be employed to correlate the data and confirm the model's ability to represent the storage site accurately. The validation of the computational model with the large quantity of measured data will be a significant element to support the non-endangerment demonstration. Further, the validation of the complete model over the entire area, and at the points where direct data collection has taken place, will ensure confidence in the model for those areas with no direct observation wells where the surface infrastructure precludes geophysical data collection.

5.4 Evaluation of Reservoir Pressure

OLCV will demonstrate non-endangerment to USDWs by showing that the pressure within the Injection Zone will rapidly decrease to levels near its pre-injection static reservoir pressure during the PISC period. Because increased pressure is the primary driving force for fluid movement that could endanger a USDW, the decay in the pressure differential provides strong justification that the injectate will no longer pose a risk to any USDWs.

OLCV will monitor the downhole reservoir pressure at various locations and intervals using a combination of surface and downhole pressure gauges. The measured pressure at a specific depth interval will be compared with the pressure predicted by the computational model, which was previously shown in Figure 1, Figure 2, and Figure 3. Agreement between the actual and predicted values will validate the accuracy of the model and further demonstrate non-endangerment.

5.5 Evaluation of Carbon Dioxide Plume

OLCV will use a combination of monitoring data, logs, geophysical surveys, and seismic methods to locate and track the movement of the CO₂ plume. The data produced by these activities will be compared with the modeled predictions (previously shown in Figure 7) using statistical methods to validate the model's ability to represent the storage site accurately. PISC monitoring data will be used to show the stabilization of the CO₂ plume as the reservoir

pressure returns to its near-pre- injection state. The risk to USDWs will decrease when the extent of pure-phase CO₂ ceases to grow either laterally or vertically. The stabilization of the CO₂ plume combined with the lack of unmitigated Artificial Penetrations in the confining formation will be significant factors in the Project's demonstration of non-endangerment.

Fluids and dissolved gasses collected from USDW1 or soil or soil gas samples may be used to determine aqueous-phase CO₂ concentrations and mobilized constituents to assess USDW endangerment. If a demonstration can be made that the majority of the CO₂ has been immobilized via trapping mechanisms, then there is strong evidence that the risk to USDWs posed by the CO₂ plume has decreased. Modeling results, including sensitivity analyses, may also be used to demonstrate that plume migration rates are negligible based on available site characterization, monitoring, and operational data.

5.6 Evaluation of Emergencies or Other Events

In addition to the CO₂ plume, mobilized fluids may also pose a risk to USDWs, as the reservoir fluids include brines that are high in total dissolved solids (TDS) and contain hydrogen sulfide. The geochemical data collected from monitoring wells will be used to demonstrate that no mobilized fluids have moved above the Upper Confining Zone and therefore would not pose a risk to USDWs after the PISC period. Monitoring data indicating steady or decreasing trends of potential drinking water contaminants below actionable levels (e.g., secondary, and maximum contaminant levels) will be used for this demonstration.

To demonstrate non-endangerment, OLCV will compare the operational and PISC period fluid and dissolved gas samples from the lowermost USDW with the pre-injection baseline samples. This comparison is expected to show chemical similarity to baseline samples. Changes in chemistry will be evaluated to demonstrate attribution. This work will demonstrate the absence of CO₂ injectate or brine forced from the Injection Zone into the lowermost USDW.

Corrective action will be performed on Artificial Penetrations identified to be potential leak pathways. Based on this information, the potential for fluid movement through artificial penetrations of the confining formation does not present a risk of endangerment to any USDWs.

6.0 Site Closure Plan

OLCV will conduct site closure activities to meet the requirements of 40 CFR §146.93(e) as described below. OLCV will submit a final Site Closure Plan and notify the permitting agency

at least 120 days in advance of its intent to close the site. Once the permitting agency has approved closure of the site, OLCV will plug the monitoring wells and submit a site closure report to EPA within 90 days of site closure. The activities described below represent the planned activities based on information provided to EPA. The actual site closure plan may employ different methods and procedures. A final Site Closure Plan will be submitted to the UIC Program Director for approval with the notification of the intent to close the site.

6.1 Plugging Monitoring Wells

Upon receiving authorization for site closure from the Director, all monitoring wells will be plugged within 90 days of site closure. All Injection Zone monitoring wells at the site will be plugged and abandoned using best practices to prevent any upward migration of the CO₂ or communication of fluids between the Injection Zone and USDWs. The deep monitoring wells in the Injection Zone have a direct connection between the injection formation and the ground surface; therefore, the well plugging program is specifically designed to prevent communication between the Injection Zone and USDWs. Details of the Plugging Program are located in the Plugging Plan document.

Before the wells are plugged, the internal and external integrity of the wells will be confirmed by conducting a pressure test and a cement and casing inspection log. The results of this logging and testing will be reviewed and approved by the appropriate regulatory agencies before plugging the wells.

Infrastructure removal and site restoration efforts will comply with applicable state and local requirements.

6.2 Site Closure Report

A Site Closure Report (SCR) will be prepared and submitted to the Director within 90 days after site closure. The SCR will document the following aspects of the site closure process:

- Plugging of all injection, water withdraw and monitoring wells;
- Details of site restoration activities;
- Location of the sealed injection well on a survey plat submitted to the local zoning authority, a copy of which will be sent to the Regional Administrator for EPA Region 6;
- Notifications sent to state and local authorities;
- Records regarding the nature, composition, and volume of CO₂ injected;

- Records of pre-injection, injection, and post-injection monitoring; and
- Certifications that all injection and storage activities have been completed.

OLCV will record a notation on the deed of the property on which the injection well was located, which will include the following:

- An indication that the property was used for carbon dioxide sequestration,
- The name of the local agency to which the survey plat with injection well location was submitted,
- The volume of fluid injected,
- The Injection Zone or zones into which the fluid was injected, and
- The period over which the injection occurred.

The site closure report will be submitted to the permitting agency and maintained by the owner or operator for a period of 10 years following site closure. Additionally, the owner or operator will maintain the records collected during the post-injection site care period for a period of 10 years after which these records will be delivered to the UIC Program Director.

ATTACHMENT 9: EMERGENCY AND REMEDIAL RESPONSE PLAN

Facility name: Brown Pelican CO2 Sequestration Project
BRP CCS1, CCS2, and CCS3 wells

Well location: Penwell, TX

BRP CCS1	31.76479314	-102.7289311
BRP CCS2	31.76993805	-102.7332448
BRP CCS3	31.76031163	-102.7101566

1.0 Plan Overview

This Emergency and Remedial Response Plan (ERRP) describes actions Oxy Low Carbon Ventures, LLC (OLCV) shall take to address movement of the injection fluid or formation fluid to prevent endangerment of an underground source of drinking water (USDW) during the construction, operation, or post-injection site care periods.

If OLCV obtains evidence that the injected CO₂ stream and/or associated pressure front may cause an endangerment to a USDW, OLCV will perform the following actions:

1. Initiate the shutdown plan for the injection well.
2. Take all steps reasonably necessary to identify and characterize any release.
3. Notify the permitting agency Underground Injection Control (UIC) Program Director of the emergency event within 24 hours.
4. Implement applicable portions of the approved ERRP.

Where the phrase “initiate shutdown plan” is used, the following protocol will be employed: OLCV will immediately cease injection. However, in some circumstances, OLCV in consultation with the UIC Program Director, will determine whether gradual cessation of injection is appropriate (using the parameters set forth in the Summary of Operating Conditions document of the Class VI permit).

2.0 Local Resources and Infrastructure

The USDWs in the vicinity of the Brown Pelican CO₂ Sequestration Project (BRP CCS or Project) that may be affected as a result of an emergency event at the project site include the Pecos Valley major aquifer and the Dockum minor aquifer. The base of the USDW in the Project area of review (AoR) is in the Dockum minor aquifer in the Santa Rosa Formation (depth range: 600 to 1,150 ft below ground level). Drainage of the Pecos Valley and Dockum aquifers from the

study area is directed towards the Pecos River (30 miles SW). Figure 1 shows the surface features within the project AoR, which mainly consist of Holocene sand and silt, dunes and dune ridges, caliche, associated alluvium, and other undivided Quaternary deposits.

The Area of Review and Corrective Action Plan document provides further details on the USDWs within the project area.

Infrastructure in the vicinity of the BRP Project that may be affected as a result of an emergency at the project site includes local solar power generation operations on the surface projection of the AoR and the direct air capture (DAC) facility adjacent to the AoR.

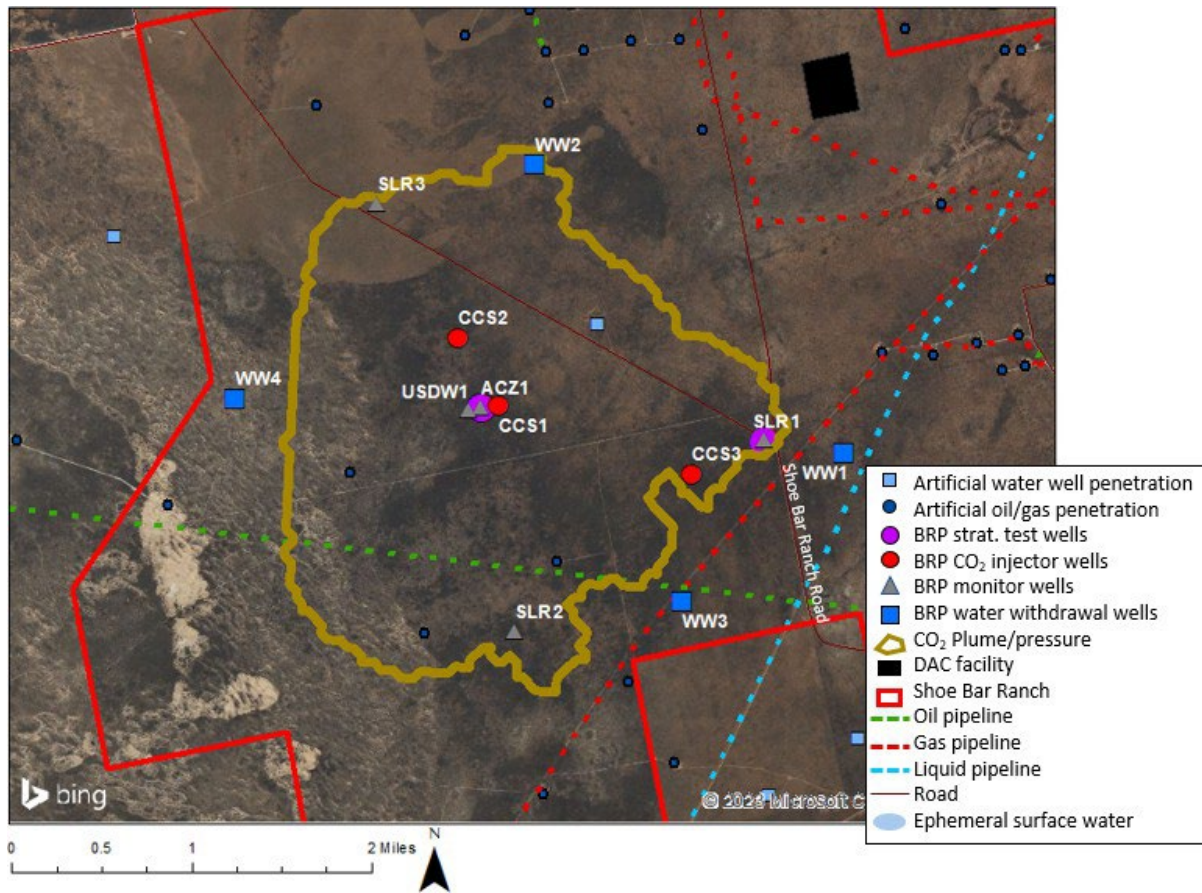

Figure 1—Map of surface features within the area of review.

3.0 Potential Risk Scenarios

The events related to the BRP Project that could potentially result in an emergency response are included in Table 1. This table lists the types of potential adverse incidents that will trigger response actions to protect USDWs if the incidents occur during the construction, injection, or post-injection site care periods. OLCV will undertake emergency or remedial actions in response to these incidents. The worst-case consequences of various scenarios have been developed to ensure that response plans are in place for all eventualities.

Table 1—Potential Emergency Events

Construction / Pre-Injection Period
<ul style="list-style-type: none"> • Well control event during drilling or completions with loss of containment
Injection Period
<ul style="list-style-type: none"> • Well integrity failure <ul style="list-style-type: none"> ○ Loss of mechanical well integrity due to tubing or packer leak in injection or monitoring well ○ Loss of mechanical well integrity due to casing leak in injection, monitoring, or water withdrawal well • Potential leakage to USDW <ul style="list-style-type: none"> ○ Vertical migration of CO₂, brines, or applicable production fluid in injection, monitoring, or water withdrawal well ○ Vertical migration of CO₂ from the Injection Zone through plugged and abandoned (P&A'd) wells in the storage complex or undocumented wells ○ Vertical migration of CO₂ from the Injection Zone through failure of the confining zone, faults, and fractures (loss of containment) ○ Lateral migration of CO₂ outside the defined AoR • Well monitoring equipment failure or malfunction (e.g., shutoff valve or pressure gauge) • A natural disaster (e.g., earthquake, tornado, hurricane, lightning strike) • Induced seismic event • Surface impacts <ul style="list-style-type: none"> ○ External impact to injection, monitoring, or water withdrawal wellhead ○ External impact to surface piping or buried pipelines ○ Loss of mechanical integrity pipeline on the surface piping or buried pipelines (e.g., internal or external corrosion) ○ Incorrect valve position leading to pipeline overpressure ○ CO₂ thermal expansion in injection pipeline
Post-Injection Site Care Period
<ul style="list-style-type: none"> • Well integrity failure <ul style="list-style-type: none"> ○ Loss of mechanical well integrity due to tubing or packer leak in monitoring well ○ Loss of mechanical well integrity due to casing leak in monitoring well • Potential leakage to USDW <ul style="list-style-type: none"> ○ Vertical migration of CO₂, brines, or applicable production fluid in monitoring well ○ Vertical migration of CO₂ from the Injection Zone through P&A'd wells in the storage complex or undocumented wells ○ Vertical migration of CO₂ from the Injection Zone through failure of the confining zone, faults, and fractures (loss of containment) ○ Lateral migration of CO₂ outside the defined AoR • Natural disaster (e.g., earthquake, tornado, lightning strike, freezing)

- Induced seismic event
- Surface impacts
 - External impact to monitoring wellhead

Response actions will depend on the severity of the event(s) triggering an emergency response. “Emergency events” are categorized as shown in Table 2.

Table 2—Risk Severity for Emergency Events

Risk Severity	Definition
Major	Emergency event poses immediate substantial risk to human health, resources, or infrastructure. Emergency actions involving local authorities (evacuation or isolation of areas) should be initiated.
Serious	Emergency event poses potential serious (or significant) near-term risk to human health, resources, or infrastructure if conditions worsen or no response actions are taken.
Minor	Emergency event poses no immediate risk to human health, resources, or infrastructure, no response action required.

4.0 Emergency Identification and Response Actions

Steps to identify and characterize the event will depend on the specific issue identified and the severity of the event. The potential risk scenarios listed in Table 1 are detailed below. OLCV will also submit a report to the Director where applicable under 40 CFR §146.91(c).

4.1 Well Control Event

Loss of containment could occur during drilling and completions operations if the hydrostatic column controlling the well decreases below the formation pressure, allowing fluids to enter the well.

Severity (residual)¹: Serious

¹ Residual severity accounts for consequences after implementation of avoidance measures and detection methods.

Timing of event: Construction / Pre-Injection

Avoidance measures: Blowout prevention (BOP) equipment, kill fluid, well control training, BOP testing protocol, kick drill, lubricators for wireline operations.

Detection methods: Flow sensor, pressure sensor, tank-level indicator, tripping displacement practices, mud weight control.

Potential response actions:

- Drilling
 - Stop operation.
 - Close BOP.
 - Clear floor and secure area.
 - Execute well control procedure.
 - Evaluate drilling parameters and identify root cause.
 - Resume operations.

- Completion
 - Stop operation.
 - Close BOP.
 - Clear floor and secure area.
 - Execute well control procedure.
 - Resume operations.

Response personnel: Rig crew and downhole (DH) contractors, rig manager, field superintendent, project manager.

4.2 Well Integrity Failure

Integrity loss of the injection well, monitoring well, and/or water withdrawal well may endanger USDWs. Integrity loss may occur during the following scenarios:

- Loss of mechanical integrity due to a tubing or packer leak in the injection well or monitoring well.

- Loss of mechanical integrity due to a casing leak in the injection well, monitoring well or water withdrawal well.

4.2.1 Loss of Mechanical Integrity: Tubing or Packer Leak in Injection Well

Loss of mechanical integrity due to a tubing or packer leak in the injection well could occur due to corrosion, damage in the tubulars during installation, packer leak (undetected), fatigue, or higher load profiles. This loss could cause a communication of the formation fluids within the annulus between the casing and tubing and sustained casing pressure. There is no loss of containment in this scenario and no movement of injection or formation fluids anticipated to endanger USDW.

Severity (residual): Minor

Timing of event: Injection

Avoidance measures: Coated tubing, inhibited packer fluid in the annulus, corrosion monitoring plan, dry CO₂ injected, trim on tubing hanger and tree, corrosion-resistant (CR) tubing tailpipes below packers, CR or Inconel[®] carrier for the sensors, new casing and tubing installed.

Detection methods: Real-time pressure and temperature gauges at the surface and downhole, electromagnetic casing inspection log, annulus pressure test, CO₂ sensor on the wellhead, distributed temperature sensing (DTS) fiber alongside production casing with real-time monitoring.

Potential response actions:

- Trigger alarm by the monitoring system or monitoring personnel.
- Follow protocol to stop operation, vent, or deviate CO₂.
- Troubleshoot the well.
- If tubing leak is detected, discuss action plan with regulating authority.
- Schedule well service to repair tubing.

Response personnel: Operations engineer, field superintendent, project manager, rig crew and DH contractors.

4.2.2 Loss of Mechanical Integrity: Tubing or Packer Leak in Monitoring Well

Loss of mechanical integrity due to a tubing or packer leak in the monitoring well could occur due to corrosion, damage in the tubulars during installation, packer leak (undetected), fatigue, or higher load profiles. This loss could cause a communication of the formation fluids within the annulus between the casing and tubing and sustained casing pressure. There is no loss of containment in this scenario and no movement of injection or formation fluids anticipated to endanger USDW.

Severity (residual): Minor

Timing of event: Injection and Post-Injection

Avoidance measures: Coated tubing, inhibited packer fluid in the annulus, corrosion monitoring plan, CR tubing tailpipes below the packer, CR or Inconel carrier for the sensors, new casing and tubing installed.

Monitoring wells are designed to be outside the projected plume for the majority of the project

operation, reducing the risk of contact with CO₂.

Detection methods: Real-time pressure and temperature gauges at the surface, downhole pressure monitoring, annulus pressure test.

Potential response actions:

- Trigger alarm by the monitoring system or monitoring personnel.
- Troubleshoot the well.
- If tubing leak is detected, discuss action plan with regulating authority.
 - Schedule well service to repair tubing.

Response personnel: Operations engineer, field superintendent, project manager, rig crew and DH contractors.

4.2.3 Loss of Mechanical Integrity: Casing Leak in Injection Well

Loss of mechanical integrity due to a casing leak in the injection well could occur due to corrosion, damage to the tubulars during installation, packer leak (undetected), fatigue, or higher load profiles. This loss could cause a migration of CO₂ and brines through the casing, the cement sheath, and into different formations than the injection target or into a USDW.

Severity (residual): Minor

Timing of event: Injection

Avoidance measures: CO₂-resistant cement and metallurgy (casing) across the Injection Zone, injection through tubing and packer, CR or Inconel carrier sensors, inhibited packer fluid in the annulus, cement to surface, corrosion monitoring plan, cement bond log (CBL) after installation, new casing installed.

Detection methods: Real-time pressure and temperature gauges at the surface and downhole, electromagnetic casing inspection log, CO₂ sensor on the wellhead, DTS fiber alongside production casing with real-time monitoring, flow rate monitoring, soil gas probes, neutron-activated logs, USDW water monitoring.

Potential response actions:

- Trigger alarm by the monitoring system or monitoring personnel.
- Follow protocol to stop operation, vent, or deviate CO₂.
- Troubleshoot the well.
- Evaluate if there is movement of CO₂ or brines to USDW.

- If USDW is affected, discuss remediation with regulating authority.
- If casing leak is detected, discuss action plan with regulating authority.
- Schedule well service to repair casing or plug and abandon (P&A) well based on findings of assessment.

Response personnel: Operations engineer, field superintendent, project manager, rig crew and DH contractors, remediation contractors.

4.2.4 Loss of Mechanical Integrity: Casing Leak in Monitoring Well

Loss of mechanical integrity due to a casing leak in the monitoring well could occur due to corrosion, damage in the tubulars during installation, packer leak (undetected), fatigue, or higher load profiles. This loss could cause a migration of CO₂ and brines through the casing, the cement sheath, and into different formations in the injection target or USDW.

Severity (residual): Minor

Timing of event: Injection and Post-Injection

Avoidance measures: CO₂-resistant cement, inhibited packer fluid in the annulus, CR or Inconel carrier sensors, cement to surface, corrosion monitoring plan, CBL after installation, new casing and tubing installed.

Monitoring wells are designed to be outside the projected plume for the majority of the project operation, reducing the risk of contact with CO₂.

Detection methods: Real-time pressure gauges at surface, downhole pressure monitoring, pulsed neutron logs, annulus pressure test.

Potential response actions:

- Trigger alarm by the monitoring system or monitoring personnel.
- Troubleshoot the well.
- Evaluate if there is movement of CO₂ or brines to USDW.
- If USDW is affected, discuss remediation with regulating authority.
- If casing leak is detected, discuss action plan with regulating authority.
- Schedule well service to repair casing or P&A the well based on findings of assessment.

Response personnel: Operations engineer, field superintendent, project manager, rig crew and DH contractors, remediation contractors.

4.2.5 Loss of Mechanical Integrity: Casing Leak in Water Withdrawal Well

Loss of mechanical integrity due to a casing leak in the water withdrawal well could occur due to corrosion, damage in the tubulars during installation, fatigue, or higher load profiles. This loss could cause a migration of brines through the casing, the cement sheath, and into different formations than the injection target or into a USDW.

While a water withdrawal well is down for repairs, it is unable to pull water from the reservoir to decrease pressure across the formation to allow for CO₂ injection. It is possible this would increase pressure in the formation from excess water and increase the area of review. However, multiple water withdrawal wells are included in the design of the Brown Pelican CO₂ Sequestration Project, so the loss of one water withdrawal well would not cause significant project concerns. Multiple water wells would need to be down for pressure to increase in the formation.

Severity (residual): Minor

Timing of event: Injection

Avoidance measures: CO₂-resistant cement and metallurgy (casing) across producing zones, CO₂-resistant electrical submersible pump (ESP) equipment, cement to surface, corrosion monitoring plan, CBL after installation, new casing and tubing installed.

Detection methods: Real-time pressure and temperature gauges at the surface and downhole, electromagnetic casing inspection log, flow rate monitoring.

Potential response actions:

- Trigger alarm by the monitoring system or monitoring personnel.
- Follow protocol to stop water production.
- Troubleshoot the well.
- Evaluate if there is movement of CO₂ or brines to USDW.
- If USDW is affected, discuss remediation with regulating authority.
- If casing leak is detected, discuss action plan with regulating authority.
- Schedule well service to repair casing or P&A the well based on findings of assessment.

Response personnel: Operations engineer, field superintendent, project manager, rig crew and DH contractors, remediation contractors.

4.3 Potential Brine or CO₂ Leakage to USDW

Potential brine or CO₂ leakage to the USDW from the injection well, monitoring well, or water withdrawal well may endanger USDWs. Integrity loss may occur during the following scenarios:

- Vertical migration of CO₂ or brine between formations through the injection well, a monitoring well, or a water withdrawal well.
- Vertical migration of CO₂ or brine between formations through legacy or P&A'd wells.
- Vertical migration of CO₂ or brine between formations due to failure of the confining rock, faults, or fractures.
- Lateral migration of CO₂ outside the defined AoR.

4.3.1 Vertical Migration of Brine or CO₂ to USDW: Injection Well

Vertical migration of brine or CO₂ during injection could occur if there are induced stresses or a chemical reaction on the tubulars or cement of the injection well exposed to the CO₂ pressure or plume.

Severity (residual): Minor

Timing of event: Injection

Avoidance measures: CO₂-resistant cement and metallurgy (casing) across the Injection Zone, injection through tubing and packer, cement to surface, CBL after installation, USDW covered as section barrier with surface casing and surface cement sheath, new casing installed, corrosion monitoring plan.

Detection methods: CO₂ sensors on the wellhead, DTS fiber alongside production casing with real-time monitoring, soil gas probes, USDW water monitoring, pulsed neutron logs to be run to determine external mechanical integrity (MI), pressure gauges at the surface, flow rate monitoring, downhole pressure monitoring.

S. Potential response actions:

- Trigger alarm by the monitoring system or monitoring personnel.
- Follow protocol to stop operation, vent, or deviate CO₂.
- Troubleshoot the well.
- Evaluate if there is movement of CO₂ or brines to USDW.
- Discuss remediation options, action plan, and monitoring plan with regulating authority, if necessary.
- Discuss plan to repair the well with the regulating authority or P&A the well

based on findings of assessment.

Response personnel: Operations engineer, field superintendent, project manager, rig crew and DH contractors, remediation contractors.

4.3.2 Vertical Migration of Brine or CO₂ to USDW: Monitoring Well

Vertical migration of brine or CO₂ during or after injection could occur if there are induced stresses or a chemical reaction on the tubulars or cement of the monitoring well exposed to the CO₂ pressure or plume.

Severity (residual): Minor

Timing of event: Injection and Post-Injection

Avoidance measures: CO₂-resistant cement across Injection Zone, CO₂-resistant metallurgy (casing) in select monitoring wells, cement to surface, CBL after installation, USDW covered as section barrier with surface casing and surface cement sheath, new casing installed, corrosion monitoring plan.

Detection methods: USDW water monitoring, pulsed neutron logs to be run for external MI, pressure gauges at surface, downhole pressure monitoring.

Potential response actions:

- Trigger alarm by the monitoring system or monitoring personnel.
- Troubleshoot the well.
- Evaluate if there is movement of CO₂ or brines to USDW.
- Discuss remediation options, action plan, and monitoring plan with regulating authority, if necessary.
- Discuss plan to repair or P&A the well with the regulating authority.

Response personnel: Operations engineer, field superintendent, project manager, rig crew and DH contractors, remediation contractors.

4.3.3 Vertical Migration of Brine or CO₂ to USDW: Water Withdrawal Well

Vertical migration of brine or CO₂ during injection could occur if there are induced stresses or a chemical reaction on the tubulars or the cement of the water withdrawal well exposed to the CO₂ pressure or plume.

Severity (residual): Minor

Timing of event: Injection

Avoidance measures: CO₂-resistant cement and metallurgy (casing) across producing zone, CO₂- resistant ESP equipment, cement to surface, CBL after installation, USDW covered as section barrier with surface casing and surface cement sheath, new casing installed, corrosion monitoring plan.

Detection methods: Real-time pressure and temperature gauges on surface and downhole, USDW water monitoring, electromagnetic casing inspection log, flowrate monitoring.

Potential response actions:

- Trigger alarm by the monitoring system or monitoring personnel.
- Follow protocol to stop water production.
- Troubleshoot the well.
- Evaluate if there is movement of CO₂ or brines to USDW.
- Discuss remediation options, action plan, and monitoring plan with regulating authority, if necessary.
- Discuss plan to repair or P&A the well with the regulating authority.

Response personnel: Operations engineer, field superintendent, project manager, rig crew and DH contractors, remediation contractors.

4.3.4 Vertical Migration of Brine or CO₂ to USDW: Legacy and P&A'd Wells

Vertical migration of brine or CO₂ during injection or post-injection could occur if there is poor cement bonding, cement degradation, or cracking in the legacy or P&A'd wells exposed to the CO₂ pressure or plume.

Severity (residual): Minor

Timing of event: Injection and Post-Injection

Avoidance measures: Legacy wells to be properly plugged and abandoned for brine movement and CO₂ plume according to the corrective action plan, injectors will be abandoned as soon as CO₂ injection in the project ends, unless they are left as monitoring wells.

Detection methods: Soil gas probes, monitoring of USDW, monitoring of injector wells that could indicate a broken seal and be causing CO₂ migration.

Potential response actions:

- Trigger alarm by the monitoring system or monitoring personnel.
- Evaluate if there is movement of CO₂ or brines to USDW due to a leak in a

legacy or P&A'd well.

- Discuss remediation options, action plan, and monitoring plan with regulating authority, if necessary.
- Discuss plan to repair the well and specific remediation actions with the regulating authority.

Response personnel: Operations engineer, field superintendent, project manager, rig crew and DH contractors, remediation contractors.

4.3.5 Vertical Migration of Brine or CO₂ to USDW: Failure of Confining Rock, Faults, or Fractures

Vertical migration of brine or CO₂ during injection could occur if the pressure of the Injection Zone exceeds the sealing capacity of the caprock or seal above or if fault or fracture features are reactivated. Brine or CO₂ could leak to a shallower formation, including a USDW.

Severity (residual): Minor

Timing of event: Injection and Post-Injection

Avoidance measures: Seismic survey in the area shows no faults in the sequestration zone, injection is limited to 90% of the fracture gradient, characterization of the rocks show good sealing capacity.

Detection methods: USDW water sampling, time-lapse seismic survey, pulsed neutron logs in injection and monitoring wells, soil gas monitoring, surface pressure monitoring.

Potential response actions:

- Trigger alarm by the monitoring system or monitoring personnel.
- Follow protocol to stop CO₂ injection and/or water production.
- Assess root cause by reviewing monitoring data.
- If required, conduct geophysical survey to delineate potential leak path.
- Evaluate if there is movement of CO₂ or brines to USDW due to a failure of confining rock, faults, or fractures.
- Discuss remediation options, action plan, and monitoring plan with regulating authority, if necessary.
- Take actions to restore injection depending on nature of the leak path and the extent.

Response personnel: Monitoring staff, geologist, reservoir engineer, project manager, remediation contractors.

4.3.6 Lateral Migration of CO₂ to Outside the Defined AoR

Lateral migration of CO₂ outside the defined AoR could occur during or after injection if the plume moves faster or in an unexpected pattern and expands beyond the secure pore space and AoR for the project.

Severity (residual): Minor

Timing of event: Injection and Post-Injection

Avoidance measures: Detailed geologic model with nearby well logging as a calibration, seismic survey integrated in the model, characterization of the rocks and formation, AoR review and calibration at least every five years, monitoring of the plume until stabilization.

Detection methods: Time-lapse seismic survey, pulsed neutron logs in monitoring wells, real-time pressure and temperature gauges in monitoring wells.

Potential response actions:

- During Injection:
 - Trigger alarm by the monitoring system or monitoring personnel.
 - Review monitoring data and trends compared with simulation.
 - Discuss findings with regulating authority; request to maintain injection during AoR evaluation if data show that CO₂ will stay in secured pore space.
 - Perform logging in monitoring wells.
 - Conduct geophysical survey as required to evaluate AoR.
 - Recalibrate model and simulate new AoR.
 - Assess if additional corrective actions are needed and if additional pore space is needed.
 - Assess if remediation is needed; prepare action plan and review with regulating authority.
 - Present AoR review to regulating authority for approval; adjust monitoring plan.
- Post-Injection:
 - Trigger alarm by the monitoring system, or monitoring personnel.
 - Review monitoring data and trends compared with simulation.
 - Discuss findings with regulating authority.
 - Conduct geophysical survey as required to evaluate AoR.

- Recalibrate model and simulate new AoR.
- Assess if additional corrective actions are needed and if additional pore space is needed.
- Assess if remediation is needed; prepare action plan and review with regulating authority.
- Present AoR review to regulating authority for approval; adjust monitoring plan.

Response personnel: Monitoring staff, geologist, reservoir engineer, project manager.

4.4 Monitoring Equipment Failure

The failure of monitoring equipment for wellhead pressure, temperature, and/or annulus pressure may indicate a problem with the injection well that could endanger USDWs.

Severity (residual): Minor

Timing of event: Injection

Avoidance measures: Preventative maintenance program, periodic inspections.

Detection methods: Real-time monitoring systems redundancy, field inspections.

Potential response actions:

- Trigger alarm by the monitoring system or monitoring personnel.
- Follow protocol to stop operation, vent, or deviate CO₂, if needed.
- If there is an injury or property damage, contact field superintendent and activate emergency evacuation to secure the location.
- Notify the UIC Program Director within 24 hours of the emergency event, per 40 CFR §146.91(c).
- Determine the severity of the event, based on the information available, within 24 hours of notification.
- Assess mechanical integrity of the system and propose repair actions, if necessary.
- Assess potential environmental impact and discuss remedial action with regulating authority.
- If assessment allows, discuss plan with the regulating authority to safely resume injection.
- Repair or replace instrumentation; calibrate equipment.
- Review monitoring records and, if needed, perform a falloff test to evaluate the

reservoir.

Response personnel: Operations engineer, field superintendent, project manager, remediation contractors, emergency teams, geologist, reservoir engineer, monitoring staff, rig crew and DH contractors.

4.5 Natural Disaster

Well problems (integrity loss, leakage, or malfunction) may arise as a result of a natural disaster affecting the normal operation of the injection well. A major seismic event may disturb surface and/or subsurface facilities; weather-related disasters (e.g., tornado, lightning strike, or freezing) may affect surface facilities.

Severity (residual): Depending on severity of event, potentially serious

Timing of event: Injection and Post-Injection

Avoidance measures: Seismic survey of the storage complex shows no faults that could be activated in the Injection Zone, shutdown devices present on wellhead and piping to shutoff CO₂ and water production.

Detection methods: Seismometers on the surface to monitor induced seismicity will detect naturally occurring major seismic event.

Potential response actions:

- Major Seismic Event
 - For event with local magnitude level (ML) from 2.0 but below 3.5 within 5.6 miles of injection well:
 - Monitor seismic activity.
 - If needed, pause operations or make adjustments to operations at a reduced rate.
 - For event with ML from 3.5 to 4.5 within 5.6 miles of injection well:
 - Initiate contact with regulating authority regarding seismic event.
 - If needed, pause operations or make adjustments to operations at a reduced rate.
 - Review regional information and monitoring records to determine origin of the event.
 - If event is induced, re-evaluate model, define new injection

- parameters, and discuss with regulating authority.
 - If assessment allows for resuming injection safely, increase surveillance to validate effectiveness of actions.
 - For event above ML 4.5 within 5.6 miles of injection well:
 - Trigger alarm by the monitoring system or monitoring personnel.
 - If there are injured personnel or property damage, contact the field superintendent to activate emergency evacuation and secure the location.
 - Follow protocol to stop injection.
 - Assess mechanical integrity of the system; propose repair actions based on findings.
 - Assess environmental impact; discuss remedial action with regulating authority, if necessary.
 - Review regional information and monitoring records to determine origin of the event.
 - If event is induced, re-evaluate model, define new injection parameters, and discuss with regulating authority.
 - If assessment allows for resuming injection safely, increase surveillance to validate effectiveness of actions.
- Weather Disaster
 - Trigger alarm by the monitoring system or monitoring personnel.
 - If there are injured personnel or property damage, contact the field superintendent to activate emergency evacuation and secure the location.
 - Follow protocol to stop CO₂ injection and/or water production.
 - Assess mechanical integrity of the system; propose repair actions based on findings.
 - Assess potential environmental impact and discuss remedial action with regulating authority.
 - If assessment allows for resuming injection and/or production safely, increase surveillance to validate effectiveness of actions.

Response personnel: Operations engineer, field superintendent, project manager, geologist,

reservoir engineer, monitoring staff, remediation contractors, emergency teams.

4.6 Induced Seismic Event

Based on the project operating conditions, it is highly unlikely that injection operations would ever induce a seismic event outside a 5.6-mile radius from the wellhead. Therefore, this portion of the response plan is developed for any seismic event with an epicenter within a 5.6-mile radius of the injection well. A geophone array on surface will be used to monitor the area for seismicity.

Severity (residual): Depending on severity of event; potentially serious

Timing of event: Injection and Post-Injection

Avoidance measures: Seismic survey of the storage complex shows no faults that could be reactivated, detailed geomechanical model created to evaluate whether the storage complex and region is seismically stable.

Detection methods: Geophone array on surface.

Potential response actions:

- For event with ML from 2.0 to 3.5 within 5.6 miles of injection well:
 - Monitor seismic activity.
 - If needed, pause operations or make adjustments to operations at a reduced rate.
- For event with ML from 3.5 to 4.5 within 5.6 miles of injection well:
 - Initiate contact with regulating authority regarding seismic event.
 - If needed, pause operations or make adjustments to operations at a reduced rate.
 - Review regional information and monitoring records to determine origin of the event.
 - If event is induced, re-evaluate model, define new injection parameters, and discuss with regulating authority.
 - If assessment allows for resuming injection safely, increase surveillance to validate effectiveness of actions.
- For event above ML 4.5 within 5.6 miles of injection well:
 - Trigger alarm by the monitoring system or monitoring personnel.
 - If there are injured personnel or property damage, contact the field

superintendent to activate emergency evacuation and secure the location.

- Follow protocol to stop injection.
- Assess mechanical integrity of the system; propose repair actions based on findings.
- Assess environmental impact; discuss remedial action with regulating authority, if necessary.
- Review regional information and monitoring records to determine origin of the event.
- If event is induced, re-evaluate the model, define new injection parameters, and discuss with regulating authority.
- If assessment allows for resuming injection safely, increase surveillance to validate effectiveness of actions.

Response personnel: Operations engineer, field superintendent, project manager, geologist, reservoir engineer, monitoring staff, remediation contractors, emergency teams.

4.7 Surface Impacts

Surface impact may cause loss of containment during the follow scenarios:

- External impact to the injection wellhead.
- External impact to the monitoring wellhead.
- External impact to the water withdrawal wellhead.
- External impact to the surface piping or buried pipelines.
- Loss of mechanical integrity due to internal or external corrosion on the surface piping or buried pipelines.
- Incorrect valve position leading to pipeline overpressure.
- CO₂ thermal expansion in the injection surface piping or buried pipelines.

4.7.1 Loss of Containment: External Impact to Injection Wellhead

External impact to the injection wellhead due to heavy trucks or equipment could cause loss of containment of brine or CO₂ if the wellhead is disconnected from the well pipe or the surface pipeline. No movement of injection or formation fluids is anticipated to endanger USDW.

Severity (residual): Serious

Timing of event: Injection

Avoidance measures: Fenced location and bollards installed, signage.

Detection methods: Real-time pressure and temperature at the wellhead and surface facilities, field inspections, optical gas imaging (OGI) cameras.

Potential response actions:

- Trigger alarm by the monitoring system or monitoring personnel.
- Automated shutdown will initiate; follow protocol to shut down CO₂ delivery if the automated shutdown devices are not functional.
- If there are injured personnel or property damage, contact the field superintendent to activate emergency evacuation and secure the location.
- Contact the field superintendent or asset manager to activate emergency plan and uncontrolled release protocol.
- Clear the location and secure the perimeter.
- Contact well control special team to execute uncontrolled release protocol that may include capping the well, drilling a relief well to kill the injector, repairing the well, or abandoning the well; discuss plan with regulating authority.
- Evaluate environmental impact to soil, water, vegetation; present remediation plan to regulating authority.
- Execute remediation and install monitoring system as needed.

Response personnel: Operations engineer, field superintendent, project manager, rig crew and DH contractors, remediation contractors, well control specialist.

4.7.2 Loss of Containment: External Impact to Monitoring Wellhead

External impact to the monitoring wellhead due to heavy trucks or equipment could cause loss of containment of brine if the wellhead is disconnected from the well pipe. No movement of injection or formation fluids is anticipated to endanger USDW.

Severity (residual): Minor

Timing of event: Injection and Post-Injection

Avoidance measures: Fenced location and bollards installed, signage, reduced pressure in the monitoring well compared with the injection well.

Detection methods: Real-time pressure at the wellhead, field inspections.

Potential response actions:

- Trigger alarm by the monitoring system or monitoring personnel.
- If there are injured personnel or property damage, contact the field superintendent to activate emergency evacuation and secure the location.
- Contact the field superintendent or asset manager to activate emergency plan and uncontrolled release protocol.
- Clear the location and secure the perimeter. If possible, install containment devices or equipment to direct fluid away from possible sensitive areas around the location.
- Contact well control special team to execute uncontrolled release protocol that may include capping the well, drilling a relief well, repairing the well, or abandoning the well; discuss plan with regulating authority.
- Evaluate environmental impact to soil, water, and vegetation; present remediation plan to regulating authority.
- Execute remediation and install monitoring system as needed.

Response personnel: Operations engineer, field superintendent, project manager, rig crew and DH contractors, remediation contractors, well control specialist.

4.7.3 Loss of Containment: External Impact to Water Withdrawal Wellhead

External impact to the water withdrawal wellhead due to heavy trucks or equipment could cause loss of containment of brine if the wellhead is disconnected from the well pipe or the surface pipeline. No movement of injection or formation fluids is anticipated to endanger USDW.

Severity (residual): Minor

Timing of event: Injection

Avoidance measures: Fenced location and bollards installed, signage.

Detection methods: Real-time pressure and temperature monitoring at surface and downhole, field inspections.

Potential response actions:

- Trigger alarm by the monitoring system or monitoring personnel.
- Automated shutdown will initiate; follow protocol to shut down water withdrawal if the automated shutdown devices are not functional.

- If there are injured personnel or property damage, contact the field superintendent to activate emergency evacuation and secure the location.
- Contact the field superintendent or asset manager to activate the emergency plan and uncontrolled release protocol.
- Clear the location and secure the perimeter. If possible, install containment devices or equipment to direct fluid away from possible sensitive areas around the location.
- Contact well control special team to execute uncontrolled release protocol that may include capping the well, drilling a relief well, repairing the well, or abandoning the well; discuss plan with regulating authority.
- Evaluate environmental impact to soil, water, and vegetation; present remediation plan to regulating authority.
- Execute remediation and install monitoring system as needed.

Response personnel: Operations engineer, field superintendent, project manager, rig crew and DH contractors, remediation contractors, well control specialist.

4.7.4 Loss of Containment: External Impact to Surface Piping or Buried Pipeline

External impact to the surface piping or buried pipeline due to heavy trucks or equipment could cause loss of containment of brine or CO₂ if the pipe ruptures. No movement of injection or formation fluids is anticipated to endanger USDW.

Severity (residual): Serious

Timing of event: Injection

Avoidance measures: Fenced location and bollards installed to protect surface piping, field pipeline is buried, pipeline right-of-way is identified with signage, One Call 811 program.

Detection methods: Real-time pressure, temperature, and flow measurement; field inspections.

Potential response actions:

- Trigger alarm by the system or operations staff.
- Automated shutdown will initiate; follow protocol to shut down CO₂ delivery or water withdrawal if the automated shutdown devices are not functional.
- If there are injured personnel or property damage, contact the field superintendent to activate emergency evacuation and secure the location.
- Clear the location and secure the perimeter. If possible, for water withdrawal

pipelines, install containment devices or equipment to direct fluid away from possible sensitive areas around the location.

- Assess mechanical integrity of the system and propose repair actions based on the findings.
- Evaluate environmental impact to soil, water, vegetation; present remediation plan to the regulating authority.
- Execute remediation and install monitoring system as needed.

Response personnel: Operations engineer, field superintendent, project manager, remediation contractors, plant manager, HSE representatives.

4.7.5 Loss of Mechanical Integrity: Internal or External Corrosion on the Surface Piping or Buried Pipeline

Loss of mechanical integrity due to internal or external corrosion in the injection pipeline or water withdrawal pipeline could cause loss of containment of brine or CO₂ if a leak develops. No movement of injection or formation fluids anticipated to endanger USDW.

Severity (residual): Serious

Timing of event: Injection

Avoidance measures: Application of asset integrity / mechanical integrity (AI/MI) program, use of lined pipe, as appropriate.

Detection methods: Real-time pressure, temperature, and flow measurement, field inspections.

Potential response actions:

- Trigger alarm by the system or operations staff.
- Automated shutdown will initiate; follow protocol to shut down CO₂ delivery or water withdrawal if the automated shutdown devices are not functional.
- If there are injured personnel or property damage, contact the field superintendent to activate emergency evacuation and secure the location.
- Clear the location and secure the perimeter. If possible, for water withdrawal pipelines, install containment devices or equipment to direct fluid away from possible sensitive areas around the location.
- Assess mechanical integrity of the system and propose repair actions based on the findings.

- Evaluate environmental impact to soil, water, vegetation; present remediation plan to regulating authority.
- Execute remediation and install monitoring system as needed.

Response personnel: Operations engineer, field superintendent, project manager, remediation contractors, plant manager, HSE representatives.

4.7.6 Loss of Containment: Incorrect Valve Position on the Surface Piping or Buried Pipeline

An incorrect valve position within the injection or production piping network could lead to high pressure within the piping and possible loss of containment of brine or CO₂ if the pipe ruptures. No movement of injection or formation fluids anticipated to endanger USDW.

Severity (residual): Serious

Timing of event: Injection

Avoidance measures: Relief valve located on pipeline at CO₂ injection wellhead, pipeline pressure rating exceeds max compressor or pump discharge pressure.

Detection methods: Real-time pressure monitoring with automatic shutdown, pressure monitoring in control room with operator response.

Potential response actions:

- Trigger alarm by the system or operations staff.
- Automated shutdown will initiate; follow protocol to shut down CO₂ delivery or water withdrawal if the automated shutdown devices are not functional.
- If there are injured personnel or property damage, contact the field superintendent to activate emergency evacuation and secure the location.
- Clear the location and secure the perimeter. If possible, for water withdrawal pipelines, install containment devices or equipment to direct fluid away from possible sensitive areas around the location.
- Assess the mechanical integrity of the system and propose repair actions based on the findings.
- Evaluate environmental impact to soil, water, and vegetation; present remediation plan to regulating authority.
- Execute remediation and install monitoring system as needed.

Response personnel: Operations engineer, field superintendent, project manager,

remediation contractors, plant manager, HSE representatives

4.7.7 Loss of Containment: CO₂ Thermal Expansion in the Injection Surface Piping or Buried Pipeline

High-pressure CO₂ has the potential for thermal expansion when exposed to high temperatures and could lead to loss of containment of CO₂ if the pipe ruptures. No movement of injection or formation fluids anticipated to endanger USDW.

Severity (residual): Serious

Timing of event: Injection

Avoidance measures: Relief valve located on the pipeline at the CO₂ injection wellhead, thermal relief valve, pipeline pressure rating exceeds maximum compressor discharge pressure.

Detection methods: Real-time pressure monitoring with automatic shutdown, pressure monitoring in control room with operator response.

Potential response actions:

- Trigger alarm by the system or operations staff.
- Automated shutdown will initiate; follow protocol to shut down CO₂ delivery if the automated shutdown devices are not functional.
- If there are injured personnel or property damage, contact the field superintendent to activate emergency evacuation and secure the location.
- Clear the location and secure the perimeter.
- Assess mechanical integrity of the system and propose repair actions based on the findings.
- Evaluate environmental impact to soil, water, and vegetation; present remediation plan to the regulating authority.
- Execute remediation and install monitoring system as needed.

Response personnel: Operations engineer, field superintendent, project manager, remediation contractors, plant manager, HSE representatives.

5.0 Response Personnel and Equipment

Site personnel, project personnel, and local authorities will be relied upon to implement the ERRP.

Monitoring, control, and routine maintenance of the injection operations will be the responsibility of the Injection Operations Staff. Site personnel are expected to include, at a

minimum, the positions listed below in Table 3.

If an adverse event is discovered, the Operations Manager and Emergency Coordinator on duty will be notified immediately. The Emergency Coordinator will be responsible for notifying offsite emergency agencies and resources. The Operations Manager will contact outside emergency response organizations if the Emergency Coordinator is not available. The EPA Region 6 UIC Program Director will also be notified within 24 hours.

Table 3—Operations Staff Descriptions

Position	Function	Qualifications
Emergency Coordinator	Responsible for notification of offsite support agencies in accordance with written procedures. Responsible for coordination and overseeing contact with the media.	Trained in the Communications Plan and Emergency Notification Procedures requirements as contained in the ERRP.
Operations Manager	Serves as the Emergency Response Manager responsible for the overall management of the Incident Response Team. Manages facility operations and personnel during an emergency and is responsible for implementation of appropriate emergency procedures and their follow-up activities.	Trained in the requirements of the ERRP and facility operations.
Project Manager	Serves as the Emergency Response Coordinator responsible for the overall communication between Incident Response Team members. Directs facility operations during an emergency and is responsible for communication between on-site personnel and professional services. Implements emergency procedures and ensures documentation of follow-up activities.	Trained in the requirements of the ERRP and facility operations.
Reservoir Engineer	Responsible for injection operation and monitoring. Lead incident response manager regarding injection and storage	Undergraduate degree in engineering, related to chemical or reservoir engineering.

	zone operation at the facility.	
Geologist/ Geophysicist	Professional serving to assist in operation, maintenance, and monitoring of the injection process. Conducts routine data management and interpretation. Assists in implementing response actions regarding Injection Zone integrity.	Undergraduate degree in geophysics or geology with specialization in hydrology/fluid mechanics.
Operations Engineer	Oversees mechanical and fluid management operation of the injection wells, annulus pressure control system, and wellhead piping systems. Maintains and repairs injection-related equipment, including valves, instruments, and piping. Assists in mechanical and electronic control of the injection process.	Undergraduate degree in engineering related to mechanical, chemical, or process control.

A site-specific emergency contact list will be developed and maintained during the life of the project. OLCV will provide the current site-specific emergency contact list to the UIC Program Director.

A list of contacts for state agencies having jurisdiction within the AoR and key local emergency agencies is presented below in Table 4.

There are no federally recognized Native American Tribes located within the AoR. If a federally recognized Native American Tribe were to exist in the AoR at the time of a site emergency, then that tribe(s) will be notified of the site emergency at that time.

Table 4—Contact Information for Key Local, State, and Other Authorities

Agency	Location	Phone
West Odessa Fire Department	West Odessa, TX	911 or 432-381-3033
Odessa Fire Rescue	Odessa, TX	911 or 432-257-0502
Odessa Police Department	Odessa, TX	911 or 432-333-3641
Odessa Regional Hospital	Odessa, TX	432-334-8000
Odessa Medical Center	Odessa, TX	432-640-4000
Highway Police	Odessa, TX	432-332-6100

Ector County Sheriff	Odessa, TX	432-335-3050
Texas Division of Emergency Management	Austin, TX	512-424-2208
Ector County Office of Emergency Management	Odessa, TX	432-257-0502
US EPA Region 6	Dallas, TX	214-665-2294

Equipment needed in the event of an emergency and remedial response will vary, depending on the triggering emergency event. Response actions (cessation of injection, well shut-in, and evacuation) will generally not require specialized equipment to implement. Where specialized equipment (such as a drilling rig or logging equipment) is required, OLCV shall be responsible for its procurement.

6.0 Emergency Communications Plan

OLCV will communicate to the public about any event that requires an emergency response to ensure that the public understands what happened and whether there are any environmental or safety implications. The amount of information, timing, and communications method(s) will be appropriate to the event, its severity, whether any impacts to drinking water or other environmental resources occurred, any impacts to the surrounding community, and their awareness of the event.

OLCV will describe what happened, impacts to the environment or other local resources, how the event was investigated, what response actions were taken, and the status of the response. For responses that occur over the long term (e.g., ongoing cleanups), OLCV will provide periodic updates on the progress of the response action(s).

OLCV will communicate with entities who need to be informed about or take action in response to the event, including local water systems, CO₂ source(s), pipeline operators, landowners, and regional response teams (as part of the National Response Team).

If a seismic event occurs, OLCV will provide information about whether the event was naturally occurring or induced by the injection, whether any damage to the well or other structures in the area occurred, the investigative process, and what responses, if any, were taken by OLCV or others.

7.0 Plan Review

This ERRP shall be reviewed:

- At least once every five (5) years following its approval by the permitting agency;
- Within one (1) year of an area of review (AOR) re-evaluation;

- Within a prescribed period (to be determined by the permitting agency) following any significant changes to the injection process or the injection facility, or an emergency event; or
- As required by the permitting agency.

If the review indicates that no amendments to the ERRP are necessary, OLCV will provide the permitting agency with the documentation supporting the “no amendment necessary” determination.

If the review indicates that amendments to the ERRP are necessary, amendments shall be made and submitted to the permitting agency within six months following an event that initiates the ERRP review procedure.

8.0 Staff Training and Exercise Procedures

All operations employees will receive training related to health and safety, operational procedures, and emergency response according to the roles and responsibilities of their work assignments. Initial training will be conducted by, or under the supervision of, the operations manager or a designated representative. Trainers will be thoroughly familiar with the Operations Plan and ERRP.

Facility personnel will participate in annual training that teaches them to perform their duties in ways that prevent CO₂ discharge. The training will include familiarization with operating procedures and equipment configurations appropriate to the job assignment as well as emergency response procedures, equipment, and instrumentation. New personnel will be instructed before beginning their work.

Refresher training will be conducted at least annually for all operations personnel. Monthly briefings will be provided to operations personnel according to their respective responsibilities and will highlight recent operating incidents, actual experience in operating equipment, and recent storage reservoir monitoring information.

Only personnel who have been properly trained will participate in drilling, construction, operations, and equipment repair at the storage site. A record including the person’s name, date of training, and instructor’s signature will be maintained.